



LABCONCO CORPORATION

8811 Prospect Avenue
Kansas City, MO 64132
(800) 821-5525, (816) 333-8811
(816) 363-0130 fax
labconco@labconco.com

User's Manual

WaterPro[®] RO Systems

Models

90750 Series

To receive important product updates,
complete your product registration card
online at register.labconco.com

Please read the User's Manual before operating the equipment.

Copyright © 2019 Labconco Corporation. The information contained in this manual and the accompanying products are copyrighted and all rights reserved by Labconco Corporation. Labconco Corporation reserves the right to make periodic design changes without obligation to notify any person or entity of such change.

Warranty

Labconco Corporation provides a warranty to the original buyer for the repair or replacement of parts and reasonable labor as a result of normal and proper use of the equipment with compatible chemicals. Broken glassware and maintenance items, such as filters, gaskets, light bulbs, finishes and lubrication are not warranted. Excluded from warranty are products with improper installation, erratic electrical or utility supply, unauthorized repair and products used with incompatible chemicals.

The warranty for WaterPro® RO Systems will expire one year from date of installation or two years from date of shipment from Labconco, whichever is sooner. Warranty is non-transferable and only applies to the owner (organization) of record.

Buyer is exclusively responsible for the set-up, installation, verification, decontamination or calibration of equipment. This limited warranty covers parts and labor, but not transportation and insurance charges. If the failure is determined to be covered under this warranty, the dealer or Labconco Corporation will authorize repair or replacement of all defective parts to restore the unit to operation. Repairs may be completed by 3rd party service agents approved by Labconco Corporation. Labconco Corporation reserves the rights to limit this warranty based on a service agent's travel, working hours, the site's entry restrictions and unobstructed access to serviceable components of the product.

Under no circumstances shall Labconco Corporation be liable for indirect, consequential, or special damages of any kind. This warranty is exclusive and in lieu of all other warranties whether oral, or implied.

Returned or Damaged Goods

Do not return goods without the prior authorization from Labconco. Unauthorized returns will not be accepted. If your shipment was damaged in transit, you must file a claim directly with the freight carrier. Labconco Corporation and its dealers are not responsible for shipping damages.

The United States Interstate Commerce Commission rules require that claims be filed with the delivery carrier within fifteen (15) days of delivery.

Limitation of Liability

The disposal and/or emission of substances used in connection with this equipment may be governed by various federal, state, or local regulations. All users of this equipment are required to become familiar with any regulations that apply in the user's area concerning the dumping of waste materials in or upon water, land, or air and to comply with such regulations. Labconco Corporation is held harmless with respect to user's compliance with such regulations.

Contacting Labconco Corporation

If you have questions that are not addressed in this manual, or if you need technical assistance, contact Labconco's Customer Service Department or Labconco's Product Service Department at 1-800-821-5525 or 1-816-333-8811, between the hours of 7:30 a.m. and 5:30 p.m., Central Standard Time.

Part #9087305, Rev. E
ECO 15437

Original Instructions

TABLE OF CONTENTS

CHAPTER 1: INTRODUCTION	1
Safety Symbols	3
CHAPTER 2: PREREQUISITES	5
Location.....	5
Electrical Requirements	6
Feedwater and Drain Requirements	6
Space Requirements	7
CHAPTER 3: GETTING STARTED	9
Unpacking Your WaterPro RO System	10
WaterPro RO System Components.....	10
Component Identification	11
Setting Up the WaterPro RO System.....	13
Feed Water Connection.....	13
Tubing Installation	13
RO Membrane Installation.....	14
Optional Dispense Gun Installation	16
WaterPro PS and Glassware Washer Feed.....	17
Operating Precautions	18
CHAPTER 4: USING YOUR WATERPRO RO SYSTEM	19
Display	20
Operating the Unit.....	21
CHAPTER 5: MAINTAINING YOUR WATERPRO RO SYSTEM ...	23
Maintenance Schedule	23
Sanitization.....	24
Service Tips.....	28
CHAPTER 6: TROUBLESHOOTING	31
Plumbing Diagram	34
APPENDIX A: WATERPRO RO SYSTEM COMPONENTS	35

APPENDIX B: WATERPRO RO SYSTEM DIMENSIONS	37
APPENDIX C: WATERPRO RO SYSTEM SPECIFICATIONS.....	38
RO Specifications.....	38
RO Production Rates Table.....	40
RO Performance Efficiency Table	41
APPENDIX D: WATERPRO RO SYSTEM ACCESSORIES.....	42
Expendables	42
Accessories.....	43
OPERATING LOG SHEET	44

Chapter 1:

Introduction

The WaterPro RO System, 90750 Series, produce reverse osmosis water upon demand. The units are equipped with a 17-liter storage tank as standard.

The unit may be interfaced with a Labconco WaterPro PS Polishing Station to directly feed the Polishing Station with RO purified water. It may also be connected to a Labconco Glassware Washer to dispense RO purified water for the final rinse cycles of the water.

An optional dispensing gun kit is available to allow easy installation in the field. The dispense gun has a 6 foot hose for remote dispensing.

The WaterPro Systems are designed to be wall mounted. An optional stand, #90774-00 is available which converts the wall-hung unit to a bench-top model.

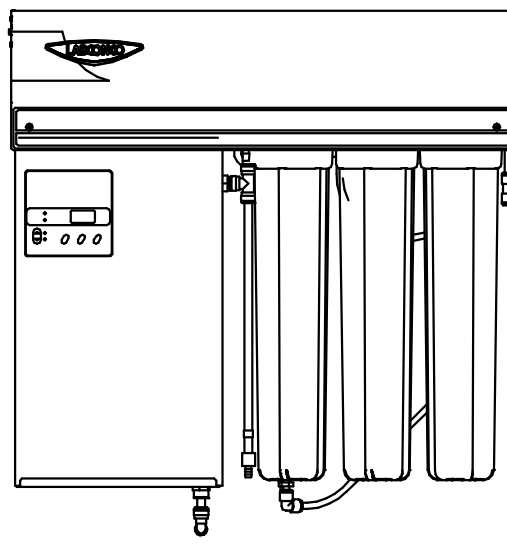

Figure 1

Chapter 1: Introduction

The WaterPro RO System dispenses reverse osmosis purified water at the rate of up to 1 liter per minute at 25°C from either the manual dispense valve or the optional dispensing gun. Water from the dispense valve may also be activated automatically by using the timed dispense feature that allows dispensing of the water for a period up to 99.9 minutes. An outlet port from the 17-liter storage tank is provided for connection to a WaterPro PS Polishing Station and/or a Labconco Glassware Washer.

The unit accepts softened or tap feed water. Softened water is preferred for extended membrane life. Softened water is required when the LSI (Langlier Saturation Index) is positive. This is determined through the Water Profile testing service from Labconco. Each model has the capability of displaying water quality in microsiemens μS , water temperature in $^{\circ}\text{C}$, timed dispense duration from 0 – 99.9 minutes and a storage tank full indication light. The RO System uses built-in activated carbon and particulate prefilters prior to the reverse osmosis membrane and storage.

The WaterPro RO Station is preset to 150 psi operating backpressure to provide an optimal RO membrane conversion rate, prolonging membrane life. See RO efficiency table on page 39 for a complete listing of RO performance.

To reduce bacterial growth in the storage tank, an automatic flush valve is incorporated to automatically flush the storage tank while flushing the RO membrane for 3 minutes every 12-hour period of inactivity. This process is controlled by the microprocessor board.

A hydrophobic filter is installed above the storage tank to filter air entering the tank as the tank empties.

When greater quantities of RO water are required, a 14 Gallon or a 20 Gallon Bladder Tank is available to provide additional storage of pressurized RO water. (Tank sold separately)

Safety Symbols

Your WaterPro RO System was designed with safety in mind; however conditions may exist that could be hazardous.



WARNING: Read and understand operator's manual before using this machine. Failure to follow operating instructions could result in death or serious injury.

AVERTISSEMENT : Lisez et comprenez le manuel d'opération avant d'utiliser cette machine. A défaut de suivre les instructions du manuel cela pourrait causer la mort ou des blessures sérieuses.

Throughout this manual potentially hazardous conditions are identified using the following words and symbols.



This is the safety alert symbol. It is used to alert you to potential personal injury hazards. Obey all safety messages that follow this symbol to avoid possible injury or death.

AVERTISSEMENT : Ceci est le symbole d'alerte de sécurité. Il est utilisé pour vous alerter aux risques de dommages corporels potentiels. Obéissez à tous les messages de sécurité qui suivent ce symbole pour éviter la possibilité de blessures corporelles ou même de la mort.

It is important that you understand the warnings listed throughout this manual before you operate the WaterPro RO.

Chapter 1: Introduction

Chapter 2:

Prerequisites

Before you install your WaterPro RO System you need to prepare your site for installation. Carefully examine the location where you intend to install your WaterPro RO. Ensure the mounting surface is of solid construction that an electrical source is located near.

Carefully read this chapter to learn:

- How to select the installation location.
- The electrical supply requirements.
- The feedwater and drain requirements.
- Space requirements

Refer to APPENDIX C: WATERPRO RO SYSTEM SPECIFICATIONS for electrical and environmental conditions, specifications and requirements.

Location



WARNING: Do not install the WaterPro RO System directly over or near equipment that uses electrical service. Routine use and maintenance of the unit may involve water spillage. A potential for electrical shock hazard exists if improperly located.

AVERTISSEMENT : N'installez pas le système WaterPro RO au-dessus de ou près d'équipements qui utilisent le service électrique. L'utilisation et l'entretien routinier peut entraîner un déversement d'eau. Un système situé près d'appareils électrique pourrait entraîner un risque de choc électrique.

Locate the RO System close to a water source and drain. The unit can be wall mounted or mounted on the optional stands.

Chapter 2: Prerequisites

Mounting surface composition, condition and construction must be considered when mounting this unit. The surface must be able to support at least 500 pounds. Inadequate support may result in damage to the mounting surface and/or equipment. Four each 1/4 x 2.0" Lg. tapping screws (1897432) are provided for securing the unit to typical wood frame wall studs. If the optional support stand has been purchased, follow instructions with stand.

When mounting next to a WaterPro PS Polishing Station use the optional electrical connection cord, part number 13060-00. This cord conveniently connects the RO to a PS. To use this cord the PS Station should be located on the left side of the RO Station.

Electrical Requirements



WARNING: Do not position the unit so that it is difficult to operate the main disconnect device.

AVERTISSEMENT : Ne positionnez pas l'unité de sorte qu'il soit difficile d'utiliser le conducteur principal de l'unité.

WARNING: Do not use any detachable power cord that is not adequately rated for the unit.

AVERTISSEMENT : N'employez aucun câble électrique détachable qui n'a pas la tension nominale pour l'unité.

The 115V WaterPro RO Station comes with a detachable 15 amp power cord which has a plug to connect to a standard outlet. For model 9075020 the electrical outlet should be rated at 115 VAC, 60 Hz, 15 Amps. Depending on the unit ordered, the 230V unit comes with a 10 amp electrical cord for connecting to a wall outlet in the EU, UK, US, China/Australia or India. The outlet for models 90750-30,-40,-60,-70,-80 should be rated 230 VAC, 50 Hz, 10 Amps and be dedicated to the RO system only. A switchable circuit breaker or a switch connected to the wall outlet should be located in close proximity to the unit to provide easily accessible disconnect of the MAINS.

For personal safety always use a three conductor power cord with the WaterPro RO to insure connection of the unit with the MAINS protective earthing ground. For safe operation the dedicated outlet must provide the protective earthing ground connection to the cabinet.

Feedwater and Drain Requirements

The WaterPro RO Systems are designed for use with feed-water that has a minimum pressure of 30 psi, a minimum flow rate of 1.6 gal/min. and a negative Langlier Saturation Index. (A positive LSI, requires water softener pretreatment. See Inlet Water Specifications on page 36 for additional information).

There are two drain lines. One is from the tank overflow drain and the other is from the RO for reject water. The drain must be located lower and must be able to handle a minimum of 2-gal/min water flow.

IMPORTANT NOTE: System performance, membrane, and cartridge life span are directly related to the feed water. It is important to establish feed water pressure, and flow rate, before installing and operating the unit. **Feed water containing more than 0.5 ppm of chlorine can cause irreversible damage to the RO membrane.** If your feed water, or feed water quality has not been tested, contact Labconco at 1-800-821-5525 or 1-816-333-8811.

Space Requirements

Wall mounted units require a minimum of 6" clearance on the bottom for cartridge, and membrane installation/removal.

Refer to APPENDIX B: WATERPRO RO SYSTEM DIMENSIONS for dimensional drawings of the WaterPro RO System.

Chapter 3:

Getting Started

Now that the site for your WaterPro RO System installation site is properly prepared, you are ready to unpack, inspect, install, and test your WaterPro RO System. Read this chapter to learn how to:

- Unpack and move your WaterPro RO System.
- Set up your WaterPro RO System.
- Connect a Glassware Washer or WaterPro PS System.
- Understand Operating Precautions

Unpacking Your WaterPro RO System

Carefully unpack your WaterPro RO System and inspect it for damage that may have occurred in transit. If your WaterPro RO System is damaged, notify the delivery carrier immediately and retain the entire shipment intact for inspection by the carrier.

The United States Interstate Commerce Commission rules require that claims be filed with the delivery carrier within fifteen (15) days of delivery.

NOTE: Do not return goods without the prior authorization of Labconco. Unauthorized returns will not be accepted. If your WaterPro RO System was damaged in transit, you must file a claim directly with the freight carrier. Labconco Corporation and its dealers are not responsible for shipping damage.

Do not discard the carton or packing material for your WaterPro RO System until you have checked all of the components and installed and tested the WaterPro RO System.

WaterPro RO System Components

The WaterPro RO System available in 115V or 230V. Locate the model of WaterPro RO System you received in the following table. Verify that the components listed are present and undamaged.

As shipped, the carton should contain the following:

<u>Part Number</u>	<u>Description</u>
90750-20 or	115V WaterPro RO System – wall mounted
90750-30,-40, -60,-70 or -80	230V WaterPro RO System – wall mounted
9087300	Manual, RO
9109100	Spanner wrench
9108200	Template
1334500 or	115V Power Cord
1336100 or	230v EU Power Cord
1338000 or	230v US Power Cord
1332600 or	230v UK Power Cord
1332700 or	230v China/AUS Power Cord
1345700	230v India Power Cord
9013415	Tube, Thermoplastic 3/8" O.D. x 1/4" I.D. x 60"
1897432	Tapping Screw, Wall Mount 1/4-14 x 2" Lg

Chapter 3: Getting Started

Component Identification (Refer to Figure 2)

1. **Control Panel.** The control panel located on the left side of the unit contains the PC board.
2. **ON/OFF Switch.** The ON/OFF switch activates the display.
3. **Pressure Gauge.** The pressure gauge indicates the RO back pressure. The pressure is preset to 150 psi. **Do not increase or decrease the pressure.**
4. **Air Vent Filter.** The air vent filter introduces bacteria-free air into the reservoir.
5. **Inlet Valve.** The inlet valve allows feed water to enter the system.
6. **Conductivity Sensor.** The conductivity sensor transmits conductivity readings of the permeate (RO purified water) to the PC board.
7. **Pressure Switch.** The pressure switch shuts down the unit when the pressure in the system reaches approximately 40 psi.
8. **Rotary Vane Pump.** The rotary vane pump boosts the pressure to the RO.
9. **Low Pressure Switch.** The low-pressure switch senses low inlet pressure and shuts off the pump to prevent pump damage.
10. **Flush Valve.** The flush valve opens to flush the membrane and storage tank after 12 hours of inactivity.
11. **Dispensing Valve.** Manual dispensing valve dispenses RO water when the valve is open and automatic timed dispense when timed dispense selected.
12. **Check Valve.** The check valve installed in the RO housing prevents damage to the membrane due to permeate backpressure.
13. **Dispensing Outlet Port.** This port allows for connection to the un-pressurize 17 L storage tank. This RO water supply can be connected to other equipment such as a polishing station or glassware washer that has it's own internal pump.
14. **Inlet Water Fitting.** Connects to feed water supply.
15. **Storage Tank.** Provides storage for 17 liters of RO purified water.
16. **Pump Motor.** ¼ HP motor drives the rotary vane pump.
17. **Float Switch.** Turns unit off when 17-liter tank is full.
18. **Storage Tank Cover.** Removable to expose storage tank.
19. **Back Pressure Relief Valve.** Provides constant back-pressure across the membrane.
20. **In line Strainer.** Filters sediment from inlet water supply to protect system.
21. **Inlet Pressure Gauge.** Monitors feed water supply pressure. Inlet pressure should be between 30 psi and 100 psi (2-7 bar).

Component Identification

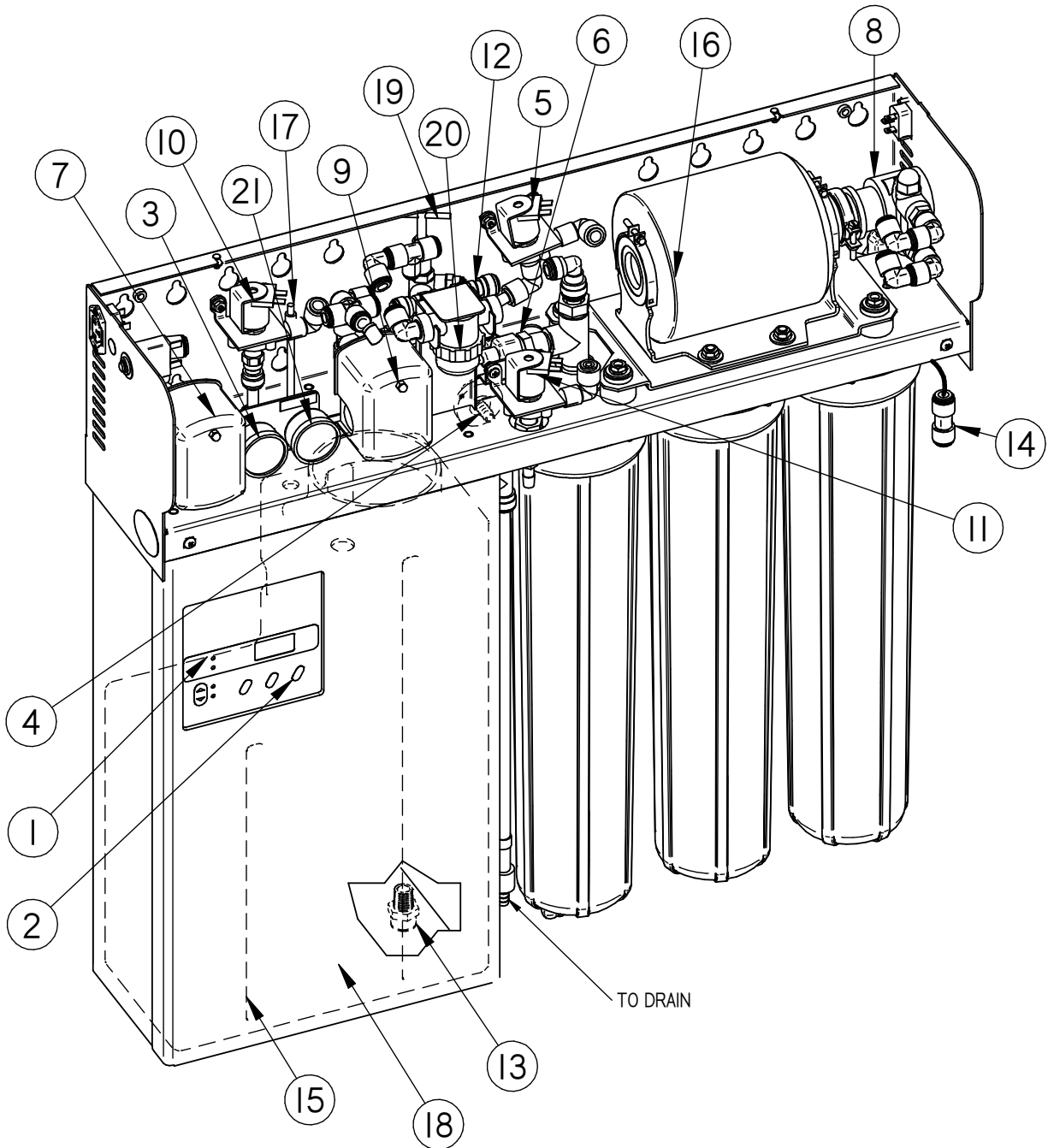

Figure 2

Chapter 3: Getting Started

Setting Up the WaterPro RO System

Unfold the installation template included and follow the instructions to mount the WaterPro RO System on a suitable wall.

If the optional Wall Mounting Panel, Support Stand or optional WaterPro RO/PS Mobile Stand has been purchased, discard the templates and follow instructions provided with the option.

When installing the WaterPro RO the unit should be lifted in place and supported from the bottom by two people on both sides of the unit.

Feed-water and Drain Connection

The supplied feed water is 3/8" OD (0.95 cm) rigid plastic tubing. If more tubing is required, refer to Replacement Parts section in this manual. The tubing is inserted into the inlet port identified as #14 on page 27. At a convenient spot in the supply line, a valve should be installed so the WaterPro RO may be isolated from the feed water supply when required. Line pressure should not exceed 100 psi (7 Bar). Feed water line must be able to supply 1.6 gal/min at a minimum pressure of 30 psi or pump cycling will occur.

To connect the feed water supply to the inlet port, cut the tube square, check for burrs, and insert into the inlet water fitting as explained in the Tubing Installation section below.

There are two drain lines. One is from the tank overflow and the other is from the RO for reject water, route both drain lines to a drain which is able to handle a minimum of 2-gal/min water flow.

Tubing Installation

The tubing connectors used in the WaterPro RO have been selected for their dependability and ease of installation. A detailed drawing of a typical connection is shown in Figure 3.

For flexible tubing, be sure to insert a tube support into the end of the tubing. Rigid tubing does not require the use of a tube support.

OPERATION OF QUICK CONNECT FITTINGS

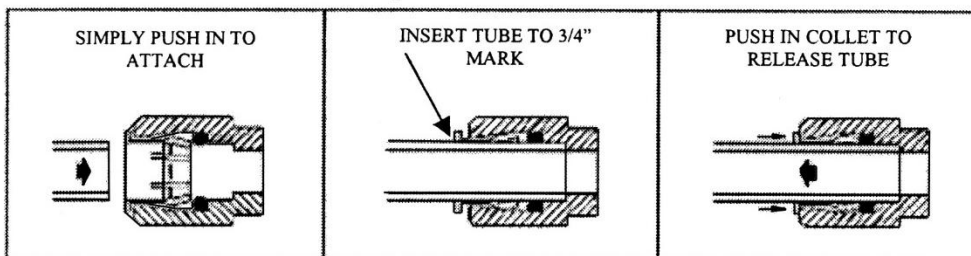

PUSHING TUBE IN BEFORE
PULLING IT OUT HELPS TO
RELEASE TUBE

Figure 3

Chapter 3: Getting Started

RO Membrane Installation

1. Install prefilter, catalog number 9092700, with the O-Rings pointing up in first bowl on the right side. Use the Spanner Wrench for bowl removal. Wear sterile laboratory gloves to prevent contamination of filters.
2. Install one carbon/filter catalog number 9059400 with the O-Rings pointing up in second bowl from the right.
3. Remove the tubing from the connector in the bottom of the third bowl by pressing the gray collar back towards the connector and pulling the tubing straight out. (See Tubing Installation, page 13).
4. With the Spanner Wrench remove the third bowl from the unit.
5. Center the lower spacer disk over the support post in the bottom of the bowl. **NOTE:** Orient the disk in the bowl so that the slots are upward. (See Figure 4).
6. Install the lower adapter into the bottom of the RO membrane by pushing it until it seats firmly.
7. Install the upper adapter in the top of the RO membrane by twisting while pushing until it seats firmly.
8. Place the Reverse Osmosis membrane in the bowl, such that the upper adapter is in the top of the bowl.
9. Install the bowl. Do not over tighten.
10. Connect the tubing into the elbow. A firm tug on the tubing should not pull it out.
11. Connect a drain line to the dispensing valve.
12. Set timed dispense for 1.5 hours and start unit. After time expires the unit will automatically shut off. (Be sure prefilter and carbon/prefilter are in place.)
13. Unit is ready for operation.

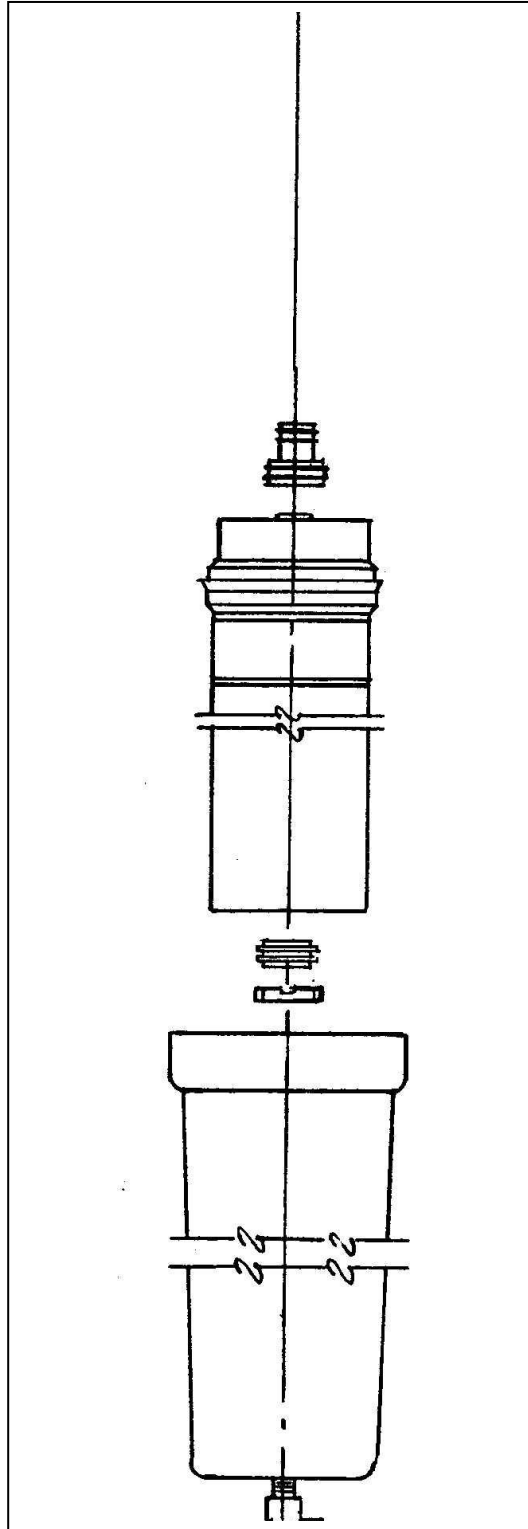

Figure 4

Chapter 3: Getting Started

Optional Dispense Gun Installation

1. Close the feed-water supply line valve and relieve pressure in system by pressing the dispense button. Disconnect from electrical power after relieving pressure.
2. Remove the two screws located on the front of the cabinet cover with a Phillips screwdriver. Loosen the two screws located on top of the cover and remove cover.
3. Remove the metal bracket with the grommet from the plastic bag.
4. Remove the storage tank cover by lifting up and pulling out. Remove the storage tank by tilting tank forward and disconnecting the float switch, electrical connection and the tank fill tubing. See Gun Installation Instruction Sheet.
5. Install the bracket on the right side of the storage tank housing using the hardware provided. See Gun Installation Instruction Sheet.
6. Remove the dispense gun with the tubing from the shipping carton.
7. Inside the cabinet of the RO unit, locate the fitting marked “GUN” which is located next to the pressure switch. Remove the plug in this fitting by pressing down on the gray collar to release the plug.
8. Push the black short tubing of the dispense gun into the end of the fitting marked “GUN”.
9. Set the gun trigger to the constant ON position and direct to drain.
10. Connect unit to electrical supply. Turn on the feed water supply valve.
11. Allow water to fill the clear tubing attached to the gun and then close the trigger to stop flow. Check for leaks.
12. Place gun in previously installed bracket so that the nozzle of the gun inserts into the black grommet on the bracket and the tubing clamps into the hose slot provided.
13. The unit is ready to be used.

WaterPro PS and Glassware Washer Feed

The WaterPro RO can be used to feed purified water to the WaterPro PS Polishing System and Labconco's Glassware Washers. To make the connection(s), first empty the storage tank of stored water. Remove a gray plug located on the bottom of the storage tank and insert tubing from either the Glassware Washer or the WaterPro PS. Connection of both the PS and Glassware Washer can be made with the use of a tee.

NOTE: If no optional storage tank is connected to the RO system the Glassware Washer will require the units 17L storage tank to be full at the beginning of the purified rinse cycle. If more than one pure rinse cycle is selected the RO system will need to be producing additional pure water in order to completely fill the washer for a second pure rinse. Use of RO water from the 17 liter tank or dispense valve during the washer rinse cycle may result in a short fill for the washer. While the storage tank is filling with water the flow rate to the dispense valve will be diminished. If multiple pure rinse cycles are required one of the optional storage tanks should be used.

Both the 14 Gallon (9203001) and 20 Gallon (9203000) Storage Tanks included the tubing required for connection to a Labconco WaterPro PS System or a Labconco Glassware Washer.

Chapter 3: Getting Started

Operating Precautions

- Pretreat feed water if indicated by the Labconco Water Profile test, to extend life of the RO membrane.
- Change prefilters frequently as stated in this manual to prevent free chlorine from destroying the RO membrane.
- Ensure that the unit is connected to electrical service according to local and national electrical codes. Failure to do so may create a fire or electrical hazard.
- Do not remove or service any electrical components without first disconnecting the RO system from the outlet.
- Preserve RO membrane whenever unit is unplugged for more than a week without usage per instructions under “Preserving RO Membrane” page 23.
- System performance and cartridge life span are directly related to the feed water quality. It is important to establish feed water quality before operating the unit.

Thoroughly understand procedures and equipment before beginning work. Prefilter, carbon/prefilter and RO membrane should already be installed. See page 14 of this manual.

CHAPTER 4

USING YOUR WATERPRO RO

SYSTEM

After your WaterPro RO System has been installed as detailed in *Chapter 3: Getting Started*, you are ready to begin using your WaterPro RO System. Read this chapter to learn how to:

- Understand the display
- Operate the unit



If the unit is not operated as specified in this manual it may impair the protection provided by the unit.

Si l'unité n'est pas utilisée comme l'indique ce manuel, cela pourrait altérer la garantie fournie par l'unité.

Display

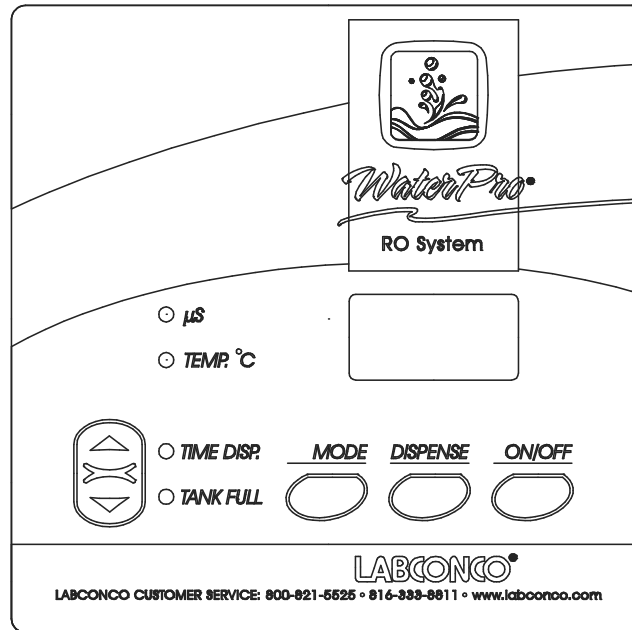

Figure 5

1. **ON/OFF Switch.** This switch turns on the unit and lights the display. When the switch is in the OFF or ON position the pump will automatically start to flush the RO membrane and tank for three minutes every 12 hours of inactivity. Before automatic flush occurs the units must be connected to an electrical supply and inactive for the 12-hour period.
2. **Mode.** This key selects the mode of operation and displays the water purity measured in conductivity.
 - a. **Microsiemens (μS).** This is the normal operating mode and displays the water purity measured in conductivity.
 - b. **Temp.** Displays temperature of the water in degrees Centigrade.
 - c. **Time Dispense.** Displays amount of time in minutes the system will dispense water from the dispense valve. Time can be increased or decreased using arrow keys.
3. **Tank Full.** Light illuminates when the storage is full.
4. **Dispense.** Pressing this key delivers water from the dispense valve. The key must be held down to continue dispensing. The delivery will be time controlled if that mode has been selected, and value entered into the display.

Operating the Unit

Initial Start Up

- Pretreat feed water as recommended by Labconco based upon the Water Profile test.
- Connect tubing to dispensing valve and direct to drain. (For gun installation, extend gun to drain and click into the ON position).
- Plug unit in electrical outlet. Turn unit ON.
- Turn the feed water valve ON.
- Set timed dispense to 99 minutes.
- Operate unit for 99 minutes to purge preservative to drain.
- Dispensing valve will close automatically, the 17 liter storage tank will fill and unit will automatically shut off.
- Unit is now ready to dispense RO water any time from the dispensing valve, optional dispensing gun or from the storage tank.

Start Up

- Plug unit into electrical outlet.
- Turn feed water valve ON.
- Turn unit ON.
- Press DISPENSE to dispense RO water from dispense valve in to vessel.

Automatic Flush Valve

The unit is equipped with a flush valve. The flush valve automatically opens every 12 hours of inactivity to flush the membrane and storage tank. In order for the flush valve to work, keep the unit plugged into an electrical outlet at all times.

Chapter 4: Using Your WaterPro RO System

Work Techniques

- Use clean glassware to collect RO water.
- Always leave unit plugged into electrical outlet. Disconnect unit to service.
- Preserve membrane if unit is left unplugged for more than a week.
- Check to ensure security of drain lines.
- Keep a log of RO performance.

Shut Down

When changing the filters or cleaning the unit, do the following:

- Press dispense to relieve system pressure.
- Unplug unit from electrical outlet.
- Turn feed valve OFF.

CHAPTER 5

MAINTAINING YOUR WATERPRO

RO SYSTEM

Under normal operation, the WaterPro RO System requires little maintenance. Read this chapter to learn:

- The Maintenance Schedule
- Sanitizing the System
- Service Tips

Maintenance Schedule

As needed

- Change prefilter and carbon/prefilter if more than 500 gallons of feed water have been processed.
- Clean unit of any dust.
- Preserve unit if unplugged for more than one week.

Monthly

- Change prefilter and carbon/prefilter once every two months.

Chapter 5: Maintaining Your WaterPro RO System

Quarterly

- Change air vent filter.

Annually

- Clean RO membrane.
- Disinfect unit.
- All monthly activities.

Biennial (once every two years)

- Replace RO membrane if the normalized (flow rate at 25°C see chart on page 30) flow rate has decreased by 20% or more.
- All annual activities.

Sanitization



**WARNING: When sanitizing the system or preserving the membrane:
Avoid splashing the solution on skin or clothing.
Ensure that all piping connections are tight to avoid leakage.
Always depressurize the system COMPLETELY before disassembly.
Ensure adequate ventilation.**

AVERTISSEMENT : Lorsque vous désinfectez le système ou préservez la membrane, évitez d'éclabousser la solution sur la peau ou les vêtements. Assurez-vous que toutes les connexions de tuyauterie soient bien serrées pour éviter toute fuite. Toujours dépressurisez le système complètement avant de le démonter. Assurez-vous une ventilation suffisante.

Chapter 5: Maintaining Your WaterPro RO System

Sanitization

Sanitization is necessary when the RO element or storage tank become biologically fouled. Biological fouling of the RO is an obstruction due to living or dead bacteria on the membrane or tank surface. This may occur if the RO is left stagnant without flushing for more than a week.

If biological fouling of the membrane occurs, the unit should be sanitized with 0.1% (wt/wt) formaldehyde as follows:

1. Collect approximately 4 liters of RO purified water in a container and set aside.



CAUTION: Use only chlorine-free water. Use of chlorinated tap water will degrade and destroy the RO membrane.

ATTENTION : Utilisez uniquement de l'eau sans chlore. L'utilisation d'eau chlorée va dégrader la membrane d'osmose inverse.

2. Shut off the feed water valve. Relieve the water pressure in the unit by opening the dispense valve (dispense gun, if installed) and directing the water to drain.
3. Disconnect the unit by unplugging it from the outlet.
4. Remove both 20" prefilter and 20" carbon/prefilter cartridges. Do not remove RO membrane.
5. Carefully wash inside the prefilter bowl, carbon/prefilter bowl and storage tank with liquid detergent using a clean sponge or cloth. Rinse out the bowls several times to remove any residue.
6. Prepare 0.1% formaldehyde in the RO purified water collected in Step 1.



CAUTION: Prepare and handle solutions in well-ventilated areas. Wear protective clothing, gloves and eye protection. Dispose of excess or spillage properly.

ATTENTION : Préparez et manipulez les solutions dans des zones bien ventilées. Portez des vêtements de protection ainsi que des gants et des lunettes de protection. Disposez de solutions excès ou d'écoulement des solutions d'une manière dûment autorisée.

7. Install a new 20" prefilter cartridge, catalog number 9021000 in the empty, clean 20" bowl.
8. Fill the carbon/prefilter bowl with the 0.1% formaldehyde.
9. Reinstall the bowls in their correct position.
10. Plug the unit into the electrical outlet. Reopen the feed water valve.
11. Start the RO unit with the dispense valve open. Allow the unit to run for five minutes.
12. Turn off feed water supply and press the manual dispense button to relieve the pressure.

Chapter 5: Maintaining Your WaterPro RO System

13. Remove the tank and sanitize with formaldehyde solution.
14. Allow the unit to stand for 1 hour.
15. If the system will not be in use for an extended time, leave the formaldehyde solution in the system.
16. If the system is to be returned to service, flush the residual solution from the vessel for 1 hour by attaching a hose to the dispensing valve and setting time dispense to 60 minutes.

Both inorganic and organic fouling is indicated when either or both of the following occur:

- The normalized (temperature corrected) product flow rate drops by 20%.
- The conductivity of the permeate rises noticeably.

Inorganic Fouling

Inorganic fouling of the membrane is caused by mineral scale such as:

- Calcium carbonate
- Calcium sulfate
- Barium sulfate
- Strontium sulfate
- Iron or manganese

Inorganic fouling can be cleaned with the following recommended solutions:

0.5% HCl with a final pH of 2

Procedure

1. Collect approximately 4 liters of reverse osmosis water in a container and set aside for use in preparing the cleaning solution.



CAUTION: Use only chlorine-free water. Use of chlorinated tap water will degrade and destroy the RO membrane.

ATTENTION : Utilisez uniquement de l'eau sans chlore. L'utilisation d'eau chlorée va dégrader la membrane d'osmose inverse.

2. Shut off feed water valve.
3. Relieve the water pressure in the unit by opening the dispense valve and directing the water to a drain.
4. Disconnect the RO unit from the electrical power source by unplugging the unit.
5. Remove the carbon/prefilter cartridge and discard the water.
6. Fill the carbon/prefilter bowl approximately $\frac{3}{4}$ full with the cleaning solution.

Chapter 5: Maintaining Your WaterPro RO System

7. Reinstall the bowl.
8. Open the feed water valve.
9. Plug the unit into an electrical outlet, activate the unit and allow it to operate for 5 minutes.
10. Disconnect the unit from the electrical outlet and allow the membrane to soak for at least 2 hours.
11. Relieve the pressure in the system by connecting unit to an electrical outlet and pressing the dispense button.



CAUTION: Do not attempt to remove the acid-filled bowls when the system is pressurized.

ATTENTION : N'essayez pas d'enlever les bols remplis d'acide lorsque le système est sous pression.

12. Carefully remove the prefilter bowl and dispose of the water appropriately.



CAUTION: The water in the bowl contains cleaning solution. Handle and dispose of properly.

ATTENTION : L'eau dans le bol contient de la solution de nettoyage. Manipulez-le et éliminez-le d'une manière dûment autorisée.

13. Install a new prefilter (first bowl from right) and carbon/prefilter (second bowl) cartridges.
14. Connect a hose to the dispensing valve and route to drain. Activate the unit by connecting the unit to an electrical outlet. Set time dispense for 60 minutes and direct water to drain.
15. At the end of the hour, set off feed-water valve and release the pressure by pressing the dispense button.
16. Start the unit. The RO module is now ready for normal operation.

Organic Fouling

Organic fouling of the membrane can be caused by silt, bacterial slime, or any other organic materials.

The following recommended cleaners may be used:

- Sodium hydroxide 0.5%
- Sodium dodecyl sulfate 0.1% (Adjust pH to 11.5 with HCl, if necessary)
- Trisodium phosphate, 1%
- Sodium tri-polyphosphate, 1%
- Tetra sodium EDTA, 1% (Adjust pH to 11.5 with HCl, if necessary)

For cleaning procedure, follow steps 1 through 17 under Inorganic Fouling.

Chapter 5: Maintaining Your WaterPro RO System

Preserving RO Membrane

If the system will not be in use (without electricity) for over a week, preserve with 0.1% formaldehyde.

1. Collect approximately 4 liters of RO water in a container. Set aside.
2. Shut off the feed-water valve and relieve the water pressure in the unit by pressing the dispense button.
3. Disconnect from the electrical supply. Remove both 20" prefilter and 20" carbon/prefilter cartridges. Do not remove RO membrane.
4. Carefully wash inside the prefilter bowl, carbon/prefilter bowl and storage tank with liquid detergent using a clean sponge or cloth. Rinse out the bowls and tank several times to remove any residue.
5. Prepare 0.1% formaldehyde in the RO water collected in Step 1.
6. Install a new 20" prefilter cartridge, catalog number 9021000 in the first bowl from the right.
7. Fill the carbon/prefilter bowl with the 0.1% formaldehyde.
8. Reinstall the bowls in their correct position.
9. Plug the unit into the electrical outlet. Reopen the feed-water valve.
10. Activate the unit and allow it to operate for 5 – 10 seconds.
11. Close the feed-water supply and disconnect the electrical source.

Service Tips



WARNING: The WaterPro RO automatically starts and stops at intervals during nonuse. To prevent the possibility of water spillage or electrical shock, always unplug the unit prior to servicing the unit.

AVERTISSEMENT : Le système WaterPro RO démarre et s'arrête automatiquement par intervalles au cours de la non-utilisation. Afin de prévenir les risques de fuite d'eau ou de choc électrique, débranchez toujours l'appareil avant de commencer l'installation.

Chapter 5: Maintaining Your WaterPro RO System

Front Cover Removal

1. Disconnect the power cord.
2. Remove the two black screws on the front panel.
3. Raise the front of the cover slightly and pull out.

Prefilter and Carbon/Prefilter Replacement

NOTE: Prefilter – change at least once a month, carbon/prefilter change at least once every two months.

1. Shut off feed-water supply and release pressure in the system by pressing the dispense valve button.
2. With the Spanner wrench provided, remove the first bowl on the right to replace the Prefilter and the middle bowl to replace the Carbon filter.
3. Remove the old filter.
4. Discard water in bowl.
5. Clean the bowl with mild soap and water, rinse and towel dry.
6. Insert new filter and place bowl on unit.
7. Hand tighten bowl in place. Do not use wrench to tighten as this may damage the bowl.

Air Vent Filter Replacement

Remove old filter and discard. Press new filter in tubing.

Chapter 5: Maintaining Your WaterPro RO System

CHAPTER 6

TROUBLESHOOTING

Refer to the following if your WaterPro RO System fails to operate properly. If the suggested corrective actions do not solve your problem, contact Labconco for additional assistance.

<u>PROBLEM</u>	<u>CAUSES</u>	<u>CORRECTIVE ACTION</u>
Unit inoperative no display	Unit not plugged into outlet	Plug WaterPro RO into appropriate electrical service
	Circuit breaker tripped/fuse blown	Reset circuit breaker/replace fuse
	Power Switch is in the OFF position	Press power button to switch system on
	Defective circuit board	Replace circuit board
Pump does not operate and no water is dispensed	Customer supplied Feed valve is closed	Open the valve
	Feed-water line is restricted, or no supply	Inspect and adjust feed-water line as required Check inline strainer for obstruction
	Pump is defective	Replace pump

Chapter 6: Troubleshooting

<u>PROBLEM</u>	<u>CAUSES</u>	<u>CORRECTIVE ACTION</u>
Reduced flow at dispense valve/gun and storage tank slow to fill	Restricted tube in the feed line or polishing system	Inspect polishing loop tubing for any restrictions
	Insufficient feed water pressure and flow rate	Pressure must be a minimum of 30 psi at a flow rate of at least 6 liters per minute Check inline strainer for obstruction
	Partial open feed valve	Open feed valve fully
	Plugged prefilter and/or carbon filter	Replace filters
	Water temperature less than 25°C	Install water temperature mixing valve
	Kinked or restricted tubing in system	Trace restriction and remove or straighten tube
	Decrease in RO back pressure	Increase back pressure relief valve to 150 psi
Water quality display acting erratically	New cartridges installed in system	Purge all of the air out of the polishing system
	Air trapped in conductivity cell	Purge all of the air out of the RO system
	Polishing loop conductivity cell not connected to wiring harness	Reconnect cell to wiring harness
	Conductivity cell is defective	Replace cell
Display reads 000	Conductivity sensor disconnected from harness	Connect sensor to harness from circuit board
	Air in conductivity sensor	Purge unit until air is expelled by opening the dispensing valve

<u>PROBLEM</u>	<u>CAUSES</u>	<u>CORRECTIVE ACTION</u>
Increase in μS (microsiemen) reading	High inlet TDS	This is normal. With increased inlet TDS, RO μS increases
	RO membrane scaling or other deposits	Clean membrane per instructions in RO cleaning section
Excessively high μS	RO membrane fouled Biofilm formed	Clean RO membrane per instructions in RO cleaning section
	RO poisoned Chlorine damage	Replace RO membrane and prefilters per installation instructions

Chapter 6: Troubleshooting

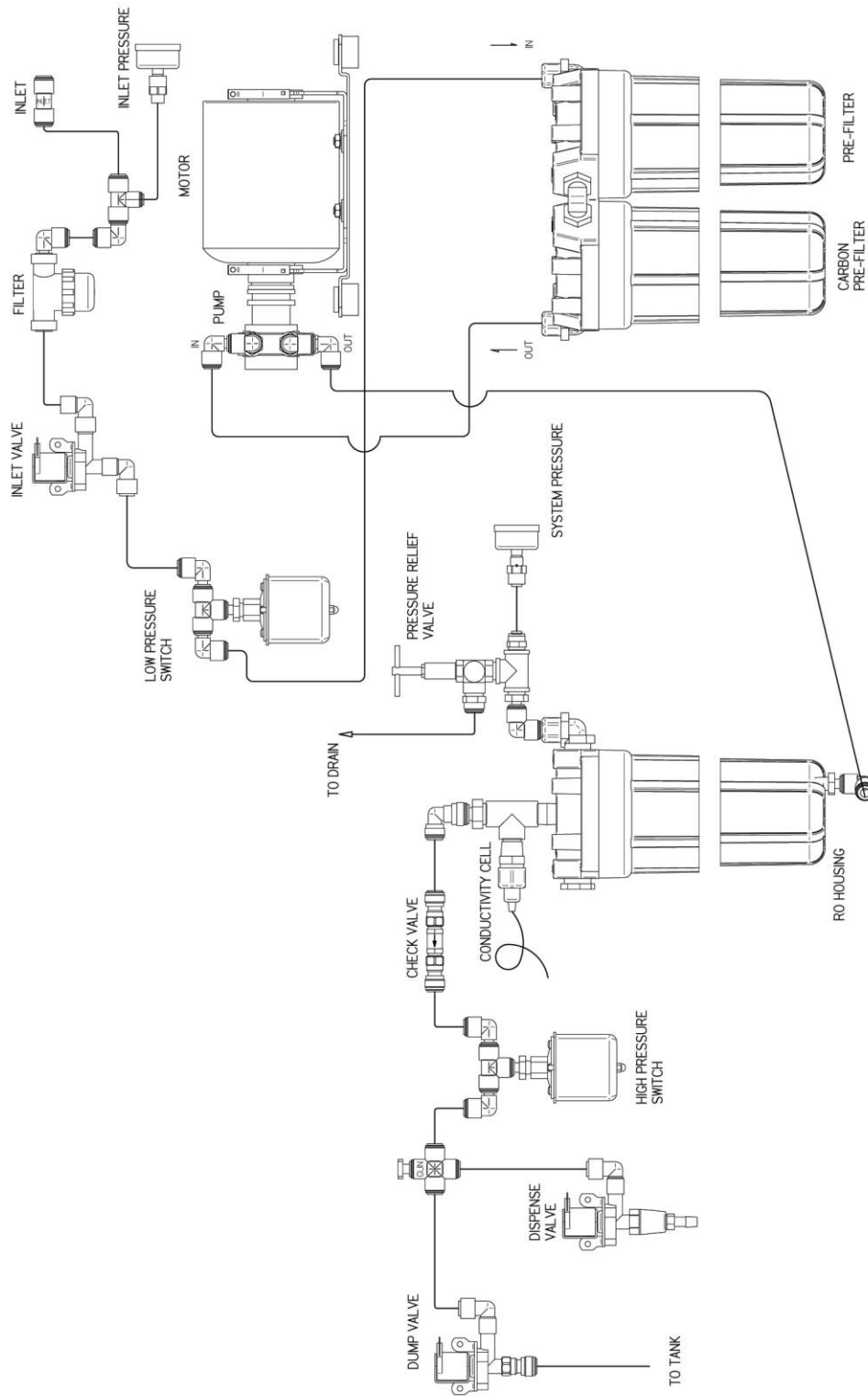

Appendix A:

WaterPro RO System Components

The following pages list components that are available for your WaterPro RO System. The parts shown are the most common replacement parts. If other parts are required, contact Product Service.

<u>ITEM #</u>	<u>QUANTITY</u>	<u>PART #</u>	<u>DESCRIPTION</u>
1	1	1363300	Check Valve
2	1	9105300	Conductivity Sensor
3	1	1329100	Low Pressure Switch
4	1	1303200	High Pressure Switch
5	1	9047503	Pump Assembly 115V
5a	1	9047502	Pump Assembly 230V
6	1	9106500	Valve - Dump/Dispense 115V/Inlet
6a	1	9108900	Valve – Dump/Dispense 230V/Inlet
7	1	1210101	Motor Pump, 115V
7a	1	1210102	Motor Pump, 230V
8	2	1953500	Pressure Gauge
9	1	9112300	PC Board Assembly
10	1	9111200	Level Switch
11	1	1365100	Valve, Pressure Relief
12	1	1930500	Air Vent Filter
13	1	9110700	Tank, Water Storage
14	5 ft.	1552500	Drain Tubing – not shown
15	5.3 ft.	9013201	Tank Overflow Drain Tubing – not shown
16	5.0 ft.	9013415	Inlet Connection Tubing – not shown
17	1	9118900	Inline Strainer

Appendix A: WaterPro RO System Components

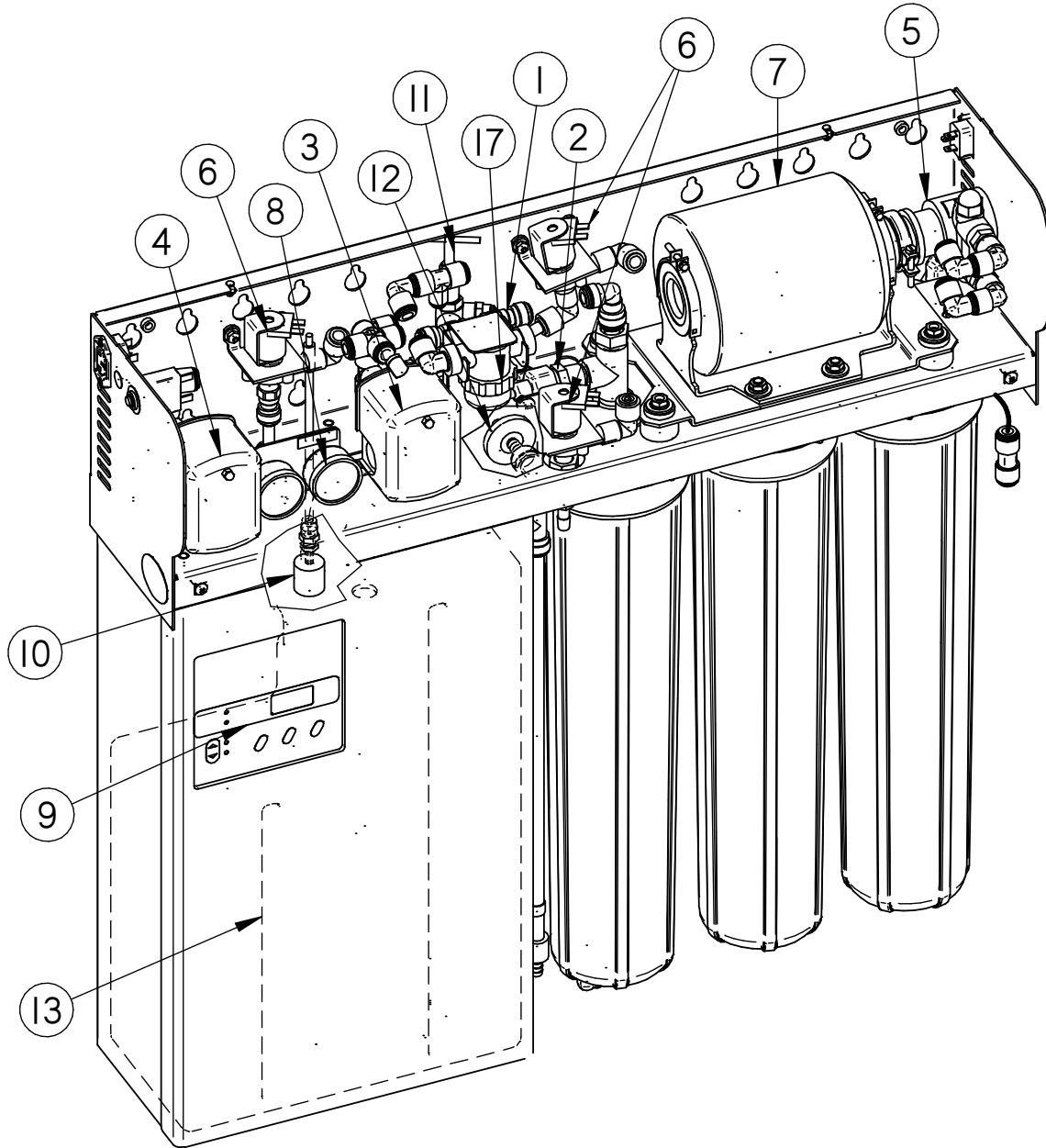

APPENDIX B

WATERPRO RO SYSTEM

DIMENSIONS

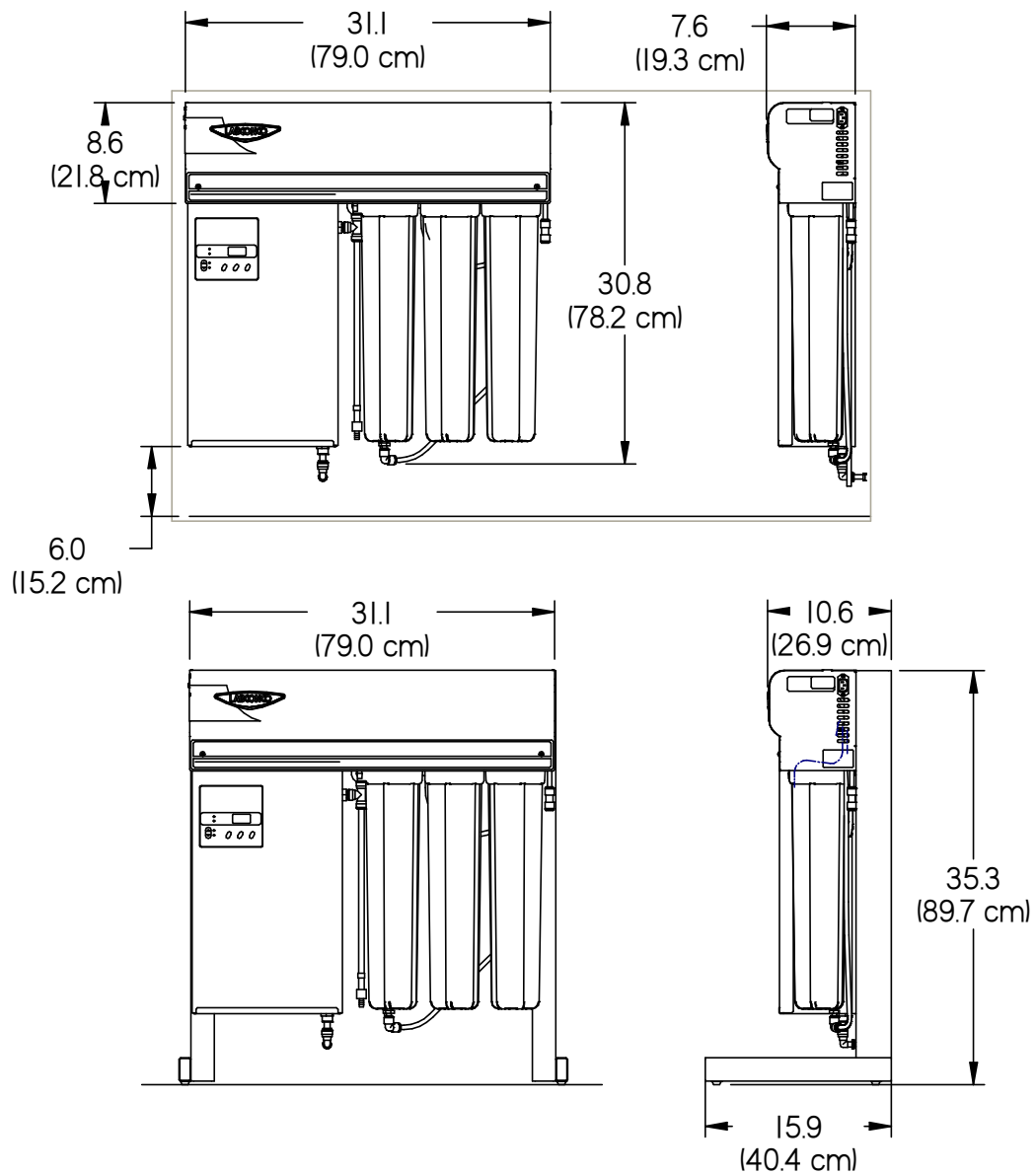

APPENDIX C

WATERPRO RO SYSTEM

SPECIFICATIONS

RO SPECIFICATIONS:

Technology:	Reverse Osmosis
Reverse Osmosis Membrane:	Polyamide thin film composite membrane
Minimum Rejection Rate:	94%
Maximum Pressure Drop per Element	6 psig
Relative Humidity:	Less than 80%
Water Dispensing System:	Manual dispensing when automatic timed dispense is not selected. Timed dispense 0 – 99.9 minutes.
RO Water Production Rate:	Port for WaterPro PS and/or Labconco Glassware Washer connection. From RO: Up to 1 L/min. (at 25°C) 8.7 L/min. typical flow (gravity) from storage tank.
Optional Storage Tanks:	70 liter with or without pump and dispensing gun. (9100000 & 9100001, 9101000 & 9101001) 20 Gal Bladder Tank 9203000 14 Gallon Bladder Tank 9203001
Electrical Specifications:	115V, 60 Hz, 12 amps or 230V, 50 Hz, 6 amps WaterPro RO is rated to provide an electrical outlet to power a WaterPro PS Polishing Station.
Sound Level:	<70dB(A) taken 1m from front cover w/pump running

INLET WATER SPECIFICATIONS:

Temperature:	5° - 40° C 41° - 104° Fahrenheit
pH:	4 – 10
Water Pressure and Flow:	30 – 100 psi (2-7 bar) 1.6 gallons/min (6 liters/min) at a minimum pressure of 30 psi

Appendix C: WaterPro RO System Specifications

Maximum Silt Density Index:	5 SDI
Turbidity:	≤ 1 NTU
Langlier Saturation Index*:	Negative (if positive, requires water softener pretreatment)

*LSI is indicated in the Water Profile water analysis test treatment. Recommendations will be provided by Labconco.

Maximum Ion Concentrations:

Iron (Total):	0.1 ppm (mg/L)
Manganese	0.1 ppm
Free Chlorine:	0.5 ppm

Environmental Conditions:

This equipment is designed to be safe under the following conditions:

- Indoor use.
- Altitude up to 6562 Ft. (2000 m).
- Maximum relative humidity 80% for temperatures up to 88°F (31°C) decreasing linearly to 50% relative humidity at 104°F (40°C).
- Main supply voltage fluctuations not to exceed ± 10% of the nominal voltage.
- Transient over-voltages according to Installation Categories II (Over-Voltage Categories per IEC 1010).
- Pollution degrees 2 normally only non-conductive foreign matter, solid, liquid, or gaseous (ionized gases), that may produce a reduction of dielectric strength or surface resistivity occurs. Occasionally, however, a temporary conductivity caused by condensation must be expected, in accordance with IEC 664.

Appendix C: WaterPro RO System Specifications

RO Production Rates Table

Temperature C	R/O Production Rates Versus Feed Water Temperature R/O Production Rates in Liters/Minute																								
	30	29	28	27	26	25	24	23	22	21	20	19	18	17	16	15	14	13	12	10	9	8	7	6	5
	0.58	0.56	0.55	0.53	0.52	0.50	0.49	0.47	0.46	0.44	0.43	0.41	0.40	0.38	0.37	0.35	0.34	0.32	0.31	0.29	0.28	0.26	0.25	0.23	0.22
	0.69	0.67	0.65	0.64	0.62	0.60	0.58	0.56	0.55	0.53	0.51	0.49	0.47	0.45	0.44	0.42	0.40	0.38	0.37	0.35	0.33	0.31	0.29	0.28	0.26
	0.80	0.78	0.76	0.74	0.72	0.70	0.68	0.66	0.64	0.62	0.60	0.57	0.55	0.53	0.51	0.49	0.47	0.45	0.43	0.41	0.39	0.36	0.34	0.32	0.30
	0.92	0.90	0.87	0.85	0.82	0.80	0.78	0.75	0.73	0.70	0.68	0.66	0.63	0.61	0.58	0.56	0.54	0.51	0.49	0.46	0.44	0.42	0.39	0.37	0.34
	1.04	1.01	0.98	0.95	0.93	0.90	0.87	0.85	0.82	0.79	0.77	0.74	0.71	0.68	0.66	0.63	0.60	0.58	0.55	0.52	0.50	0.47	0.44	0.41	0.39
	1.15	1.12	1.09	1.06	1.03	1.00	0.97	0.94	0.91	0.88	0.85	0.82	0.79	0.76	0.73	0.70	0.67	0.64	0.61	0.58	0.55	0.52	0.49	0.46	0.43
	1.27	1.23	1.20	1.17	1.13	1.10	1.07	1.03	1.00	0.97	0.94	0.90	0.87	0.84	0.80	0.77	0.74	0.70	0.67	0.64	0.61	0.57	0.54	0.51	0.47
	1.38	1.34	1.31	1.27	1.24	1.20	1.16	1.13	1.09	1.06	1.02	0.98	0.95	0.91	0.88	0.84	0.80	0.77	0.73	0.70	0.66	0.62	0.59	0.55	0.52
	1.50	1.46	1.42	1.38	1.34	1.30	1.26	1.22	1.18	1.14	1.11	1.07	1.03	0.99	0.95	0.91	0.87	0.83	0.79	0.75	0.72	0.68	0.64	0.60	0.56
	1.61	1.57	1.53	1.48	1.44	1.40	1.36	1.32	1.27	1.23	1.19	1.15	1.11	1.06	1.02	0.98	0.94	0.90	0.85	0.81	0.77	0.73	0.69	0.65	0.60
	1.73	1.68	1.64	1.59	1.55	1.50	1.46	1.41	1.37	1.32	1.28	1.23	1.19	1.14	1.10	1.05	1.01	0.96	0.92	0.87	0.83	0.78	0.74	0.69	0.65
	1.84	1.79	1.74	1.70	1.65	1.60	1.55	1.50	1.46	1.41	1.36	1.31	1.26	1.22	1.17	1.12	1.07	1.02	0.98	0.93	0.88	0.83	0.78	0.74	0.69
	1.96	1.90	1.85	1.80	1.75	1.70	1.65	1.60	1.55	1.50	1.45	1.39	1.34	1.29	1.24	1.19	1.14	1.09	1.04	0.99	0.94	0.88	0.83	0.78	0.73
	2.07	2.02	1.96	1.91	1.85	1.80	1.75	1.69	1.64	1.58	1.53	1.48	1.42	1.37	1.31	1.26	1.21	1.15	1.10	1.04	0.99	0.94	0.88	0.83	0.77
	2.19	2.13	2.07	2.01	1.96	1.90	1.84	1.78	1.73	1.67	1.62	1.56	1.50	1.44	1.39	1.33	1.27	1.22	1.16	1.10	1.05	0.99	0.93	0.87	0.82
	2.30	2.24	2.18	2.12	2.06	2.00	1.94	1.88	1.82	1.76	1.70	1.64	1.58	1.52	1.46	1.40	1.34	1.28	1.22	1.16	1.10	1.04	0.98	0.92	0.86

To read this chart: For example, if your regular Flow rate is 1.00 liter at 25°C, read the 25°C in the left column, move across the page to the 1.00. If the temperature of the water is now 19°C, locate 19°C on the left side and move across into the same column as the 1.00. The flow rate will now be 0.82 LPM (820 ml/min).

Appendix C: WaterPro RO System Specifications

RO Performance Efficiency Table

WaterPro Reverse Osmosis and WaterPro PS HPLC and HPLC/UF Hybrid Models						WaterPro Reverse Osmosis and WaterPro PS General Chemistry and UF Life Science Models					
Tap Water Conductivity uS/cm	RO Performance 95% Reduction	Resulting RO Water Purity uS/cm	PS Ion Removal Capacity 70% Efficiency	Liters of Type I Water Produced Megohm/cm	Tap Water Conductivity uS/cm	RO Performance 95% Reduction	Resulting RO Water Purity uS/cm	PS Ion Removal Capacity 70% Efficiency	Liters of Type I Water Produced Megohm/cm		
2000	x .05	100	915 Grains	1,183	2000	x .05	100	1,373 Grains	1,775		
1500	x .05	75	915 Grains	1,577	1500	x .05	75	1,373 Grains	2,367		
1000	x .05	50	915 Grains	2,366	1000	x .05	50	1,373 Grains	3,550		
900	x .05	45	915 Grains	2,629	900	x .05	45	1,373 Grains	3,944		
800	x .05	40	915 Grains	2,957	800	x .05	40	1,373 Grains	4,437		
700	x .05	35	915 Grains	3,380	700	x .05	35	1,373 Grains	5,071		
600	x .05	30	915 Grains	3,943	600	x .05	30	1,373 Grains	5,917		
500	x .05	25	915 Grains	4,732	500	x .05	25	1,373 Grains	7,100		
400	x .05	20	915 Grains	5,914	400	x .05	20	1,373 Grains	8,875		
300	x .05	15	915 Grains	7,886	300	x .05	15	1,373 Grains	11,833		
200	x .05	10	915 Grains	11,829	200	x .05	10	1,373 Grains	17,750		
100	x .05	5	915 Grains	23,658	100	x .05	5	1,373 Grains	35,499		
90	x .05	4.5	915 Grains	26,286	90	x .05	4.5	1,373 Grains	39,444		
80	x .05	4	915 Grains	29,572	80	x .05	4	1,373 Grains	44,374		
70	x .05	3.5	915 Grains	33,796	70	x .05	3.5	1,373 Grains	50,713		
60	x .05	3	915 Grains	39,429	60	x .05	3	1,373 Grains	59,165		
50	x .05	2.5	915 Grains	47,315	50	x .05	2.5	1,373 Grains	70,998		
40	x .05	2	915 Grains	59,144	40	x .05	2	1,373 Grains	88,748		
30	x .05	1.5	915 Grains	78,858	30	x .05	1.5	1,373 Grains	118,331		
20	x .05	1	915 Grains	118,288	20	x .05	1	1,373 Grains	177,496		
10	x .05	0.5	915 Grains	236,575	10	x .05	0.5	1,373 Grains	354,992		
5	x .05	0.25	915 Grains	473,150	5	x .05	0.25	1,373 Grains	709,984		
1	x .05	0.05	915 Grains	2,365,751	1	x .05	0.05	1,373 Grains	3,549,919		
1,000	No Pretreatment w/RO System: if pretreatment with an RO System is not utilized with tap water that has a conductivity of 200 to 1,000 uS/cm, minimal volume of Type I Water is obtained per filter set.	No Pretreatment w/RO System: if pretreatment with an RO System is not utilized with tap water that has a conductivity of 200 to 1,000 uS/cm, minimal volume of Type I Water is obtained per filter set.	915 Grains	118	1,000	No Pretreatment w/RO System: if pretreatment with an RO System is not utilized with tap water that has a conductivity of 200 to 1,000 uS/cm, minimal volume of Type I Water is obtained per filter set.	No Pretreatment w/RO System: if pretreatment with an RO System is not utilized with tap water that has a conductivity of 200 to 1,000 uS/cm, minimal volume of Type I Water is obtained per filter set.	1,373 Grains	177		
900			915 Grains	131	900			1,373 Grains	197		
800			915 Grains	148	800			1,373 Grains	222		
700			915 Grains	169	700			1,373 Grains	254		
600			915 Grains	197	600			1,373 Grains	296		
500			915 Grains	237	500			1,373 Grains	355		
400			915 Grains	296	400			1,373 Grains	444		
300			915 Grains	394	300			1,373 Grains	592		
200			915 Grains	591	200			1,373 Grains	887		
100			915 Grains	1,183	100			1,373 Grains	1,775		

If a customer starts with tap water that has a conductivity of 2,000 uS/cm and feeds it to an RO System the resulting dispense water conductivity will be 100uS/cm. If the customer connects the RO dispense to a PS System, they should be able to obtain an estimated 1,183 Liters of Type I water per filter set.

APPENDIX D

WATERPRO RO SYSTEM

EXPENDABLES AND ACCESSORIES

Expendables

<u>KIT #</u>	<u>DESCRIPTION</u>
9078700	Reverse Osmosis membrane and adapter package. Required for operation.
9062200	Replacement Carbon/Prefilter contains 2 each.
9067201	Prefilter/Carbon Filter Kit required for operation. Includes prefilters (3), carbon filters (3), for initial start-up and two filter changes.
1930500	Air Vent Filter
<u>Catalog #</u>	
9092700	20" Prefilter, combination carbon included in 9067201
9059400	20" Carbon/Prefilter 1 of 9062200. Included in 9067201
9078700	RO Membrane

Appendix D: WaterPro RO Expendables and Accessories

Accessories

<u>ACCESSORY</u> <u>Catalog #</u>	<u>DESCRIPTION</u>
9113100	Gun Kit Allows in field installation of an optional gun to dispense RO water
9078800	Wall Mounting Panel Kit Stainless Steel panel that mounts to the wall behind the WaterPro PO and PS systems. System facilitates installation and helps to protect the wall from moisture.
9077400	Support Stand for converting wall mounted WaterPro RO System to bench mounted
9113200	WaterPro RO/PS Mobile Stand allows the mounting of a RO and a PS on the same mobile stand
1306000	WaterPro RO/PS 125-230 Volt, 10 amp, electrical connecting cord for connecting PS to RO when mounted within 15 inches of each other
9203001	14 gallon RO Storage Tank Provides additional pressurize storage for RO water.
9203000	20 gallon RO Storage Tank Provides additional pressurize storage for RO water.

