



## Technology for Vacuum Systems

### Instructions for use



- ME 2C NT
- ME 4C NT
- ME 4C NT + 2 AK
- ME 8C NT
- ME 8C NT + 2 AK
- MZ 2C NT
- MZ 2C NT + 2 AK
- MZ 2C NT + AK + M + D
- MZ 2C NT + AK + EK
- MZ 2C NT + AK Synchro + EK
- MD 4C NT
- MD 4C NT + 2 AK
- MD 4C NT + AK + EK
- MD 4C NT + AK Synchro + EK
- PC 101 NT
- PC 201 NT

**Chemistry diaphragm pumps**  
**Chemistry vacuum systems**  
**Chemistry pumping units**

Dear customer,

Your VACUUBRAND diaphragm pumps are designed to provide you with many years of trouble-free service with optimal performance. Our many years of practical experience allow us to provide a wealth of application and safety information. Please read these instructions for use before the initial operation of your pump.

VACUUBRAND diaphragm pumps combine our many years of experience in design, construction and practical operation, with the latest developments in material and manufacturing technology.

Our quality maxim is the "zero defect" principle:

Every diaphragm pump, before leaving our factory, is tested intensively, including an endurance run of 18 hours. Any faults, even those which occur rarely, are identified and can be eliminated immediately.

After completion of the endurance run, every pump is tested, and must achieve specifications before shipment.

We are committed to providing our customers only pumps that meet this high quality standard.

While our pumps cannot eliminate all of your work, we design, manufacture and test them to ensure that they will be an effective and trouble-free tool to assist you in that work.

Yours,

VACUUBRAND GMBH + CO KG

### **After sales service:**

**Contact your local dealer or call +49 9342 808-5500.**

### **Trademark index:**

VACUU•LAN® (US-Reg.No 3,704,401), VACUU•BUS™, VACUU•CONTROL™, chemistry-HYBRID™, Peltronic™, TURBO•MODE™, VARIO® (US-Reg.No 3,833,788), VARIO-SP™, VACUUBRAND® (US-Reg.No 3,733,388) and also the shown company logos are trademarks of VACUUBRAND GMBH + CO KG in Germany and/or other countries.

## DE

Achtung: Die vorliegende Betriebsanleitung ist nicht in allen EU-Sprachen verfügbar. Der Anwender darf die beschriebenen Geräte nur dann in Betrieb nehmen, wenn er die vorliegende Anleitung versteht oder eine fachlich korrekte Übersetzung der vollständigen Anleitung vorliegen hat. Die Betriebsanleitung muss vor Inbetriebnahme der Geräte vollständig gelesen und verstanden werden, und alle geforderten Maßnahmen müssen eingehalten werden.  "Sicherheitshinweise für Vakuumgeräte"

## EN

Attention: This manual is not available in all languages of the EU. The user must not operate the device if he does not understand this manual. In this case a technically correct translation of the complete manual has to be available. The manual must be completely read and understood before operation of the device and all required measures must be applied.  "Safety instructions for vacuum equipment"

## FR

Attention: Le mode d'emploi présent n'est pas disponible dans toutes les langues d'Union Européenne. L'utilisateur ne doit mettre le dispositif en marche que s'il comprend le mode d'emploi présent ou si une traduction complète et correcte du mode d'emploi est sous ses yeux. Le dispositif ne doit pas être mis en marche avant que le mode d'emploi ait été lu et compris complètement et seulement si le mode d'emploi est observé et tous les mesures demandées sont prises.

 «Avis de sécurité pour des dispositifs à vide»

## BG

Внимание: Тези инструкции не са преведени на всички езици от ЕО. Потребителят не бива да работи с уреда, ако не разбира инструкциите за ползване. В този случай е необходимо да бъде предоставен пълен технически превод на инструкциите за ползване. Преди работа с уреда е задължително потребителят да прочете изцяло инструкциите за работа.

 "Указания за безопасност за вакуумни уреди"

## CN

注意：该操作手册不提供所有的语言版本。操作者在没有理解手册之前，不能操作该设备。在这种情况下，需要有一个整个操作手册技术上正确的翻译。在操作该设备前，必须完全阅读并理解该操作手册，必须实施所有需要的测量。

 真空设备的安全信息

## CZ

Upozornění :Tento návod k použití není k dispozici ve všech jazycích Evropské unie. Uživatel není oprávněn požit přístroj pokud nerozumí tomuto návodu. V takovém případě je nutno zajistit technicky korektní překlad manuálu do češtiny. Návod musí být uživatelem prostudován a uživatel mu musí plně porozumět před tím než začne přístroj používat. Uživatel musí dodržet všechna příslušná a požadovaná opatření.  "Bezpečnostní upozornění pro vakuové přístroje".

## DA

Bemærk: Denne manual foreligger ikke på alle EU sprog. Brugeren må ikke betjene apparatet hvis manualen ikke er forstået. I det tilfælde skal en teknisk korrekt oversættelse af hele manual stilles til rådighed. Manual skal være gennemlæst og forstået før apparatet betjenes og alle nødvendige forholdsregler skal tages.

 »Sikkerhedsregler for vakuumdstyr«

## EE

Tähelepanu! Käesolev kasutusjuhend ei ole kõigis EL keeltes saadaval. Kasutaja ei tohi seadet käsitseda, kui ta ei saa kasutusjuhendist aru. Sel juhul peab saadaval olema kogu kasutusjuhendi tehniliselt korrektne tõlge. Enne seadme kasutamist tuleb kogu juhend läbi lugeda, see peab olema arusaadav ning kõik nõutud meetmed peavad olema rakendatud.  "Ohutusnõuded vaakumseadmetele"

## ES

Atención: Este manual no está disponible en todos los idiomas de UE. El usuario no debe manejar el instrumento si no entiende este manual. En este caso se debe disponer de una traducción técnicamente correcta del manual completo. El manual debe ser leído y entendido completamente y deben aplicarse todas las medidas de seguridad antes de manejar el instrumento.  "Notas sobre la seguridad para equipos de vacío"

## FI

Huomio: Tämä käyttöohje ei ole saatavilla kaikilla EU: n kielillä. Käyttäjä ei saa käyttää laitetta, jos hän ei ymmärrä tätä ohjekirjaa. Tässä tapauksessa on saatavilla oltava teknisesti oikein tehty ja täydellinen ohjekirjan käännös. Ennen laitteen käyttöä on ohjekirja luettava ja ymmärrettävä kokonaan sekä suoritettava kaikki tarvittavat valmistelut ja muut toimenpiteet.  "Vakuumlaitteen turvallisuustiedot"

## GR

Προσοχή! : Οι οδηγίες αυτές δεν είναι διαθέσιμες σε όλες τις γλώσσες της Ευρωπαϊκής Ένωσης. Ο χρήστης δεν πρέπει να θέσει σε λειτουργία την συσκευή αν δεν κατανοήσει πλήρως τις οδηγίες αυτές. Σε τέτοια περίπτωση ο χρήστης πρέπει να προμηθευτεί ακριβή μετάφραση του βιβλίου οδηγιών. Ο χρήστης πρέπει να διαβάσει και να κατανοήσει πλήρως τις οδηγίες χρήσης και να λάβει όλα τα απαραίτητα μέτρα πριν θέσει σε λειτουργία την συσκευή.  "Υποδείξεις ασφάλειας για αντλίες κενού"

## HR

Pažnja: ove upute ne postoje na svim jezicima Europske Unije. Korisnik nemora raditi sa aparatom ako ne razumije ove upute. U tom slučaju tehnicki ispravni prijevod cijelih uputstava mora biti na raspolaganju. Uputstva moraju biti cijela procitana i razumljiva prije rada sa aparatom i sve zahtijevane mjere moraju biti primjenjene.

 "Sigurnosne napomene za vakuumske uređaje"

## HU

Figyelem! Ez a kezelési utasítás nem áll rendelkezésre az EU összes nyelvén. Ha a felhasználó nem érti jelen használati utasítás szövegét, nem üzemeltetheti a készüléket. Ez esetben a teljes gépkönyv fordításáról gondoskodni kell. Üzembe helyezés előtt a kezelőnek végig kell olvasnia, meg kell értenie azt, továbbá az üzemeltetéshez szükséges összes mérést el kell végeznie.  "A vákuum-készülékekkel kapcsolatos biztonsági tudnivalók"

## IT

Attenzione: Questo manuale non è disponibile in tutte le lingue della Comunità Europea (CE). L'utilizzatore non deve operare con lo strumento se non comprende questo manuale. In questo caso deve essere resa disponibile una traduzione tecnicamente corretta del manuale completo. Il manuale deve essere completamente letto e compreso prima di operare con lo strumento e devono essere applicati tutti gli accorgimenti richiesti.  "Istruzioni di sicurezza per apparecchi a vuoto"

## JP

注意：この取扱説明書はすべての言語で利用可能ではありません。もしこの取扱説明書を理解できないならば、ユーザーは装置を操作してはなりません。この場合、技術的に正しい翻訳がなされた完全なマニュアルを用意しなければなりません。装置を作動する前にマニュアルを完全に読み、そして理解されなくてはなりません。そして、すべての要求される対策を講じなければなりません。

 真空装置を安全に取り扱うために

## KR

주의: 이 매뉴얼은 모든 언어로 번역되지 않습니다. 만약 이 매뉴얼의 내용을 충분히 인지하지 못했다면 기기를 작동하지 마십시오. 매뉴얼의 내용을 기술적으로 정확하게 번역한 경우에 이용하십시오. 기기를 사용하기 전에 이 매뉴얼을 충분히 읽고 이해하고 모든 요구되는 사항들을 적용해야 합니다.

 진공 장비에 대한 안전 정보

## LT

Dėmesio: šis vadovas nėra pateikiamas visomis ES kalbomis. Naudotojui draudžiama eksploatuoti įtaisą, jeigu jis nesupranta šio vadovo. Tokiu atveju reikia turėti viso vadovo techniškai taisyklingą vertimą. Vadovą būtina visą perskaityti ir suprasti pateikiamas instrukcijas prieš pradėdant eksploatuoti įtaisą, bei imtis visų reikiamų priemonių.  "Vakuuminės įrangos saugos informacija"

## LV

Uzmanību: Lietotāja instrukcija nav pieejama visās ES valodās. Lietotājs nedrīkst lietot iekārtu, ja viņš nesaprot lietotāja instrukcijā rakstīto. Šādā gadījumā, ir nepieciešams nodrošināt tehniski pareizu visas lietotāja instrukcijas tulkojumu. Pirms sākt lietot iekārtu, un, lai izpildītu visas nepieciešamās prasības, iekārtas lietotāja instrukcija ir pilnībā jāizlasa un jāsaprot.  "Vakuuma iekārtu drošības noteikumi"

## NL

Attentie: Deze gebruiksaanwijzing is niet in alle talen van de EU verkrijgbaar. De gebruiker moet niet met dit apparaat gaan werken als voor hem/haar de gebruiksaanwijzing niet voldoende duidelijk is. Bij gebruik van deze apparatuur is het noodzakelijk een technisch correcte vertaling van de complete gebruiksaanwijzing te hebben. Voor het in gebruik nemen van het apparaat moet de gebruiksaanwijzing volledig gelezen en duidelijk zijn en dienen alle benodigde maatregelen te zijn genomen.  "Veiligheidsvoorschriften voor vacuümapparaten"

## PL

Uwaga!! Ta instrukcja nie jest dostępna we wszystkich językach Unii Europejskiej. Użytkownik nie może rozpocząć pracy z urządzeniem dopóki nie przeczytał instrukcji i nie jest pewien wszystkich informacji w niej zawartych. Instrukcja musi być w całości przeczytana i zrozumiana przed podjęciem pracy z urządzeniem oraz należy podjąć wszystkie niezbędne kroki związane z prawidłowym użytkowaniem.

 "Wskazówki bezpieczeństwa do urządzeń próżniowych"

## PT

Atenção: Este manual não está disponível em todas as línguas da UE. O usuário não deve utilizar o dispositivo, se não entender este manual. Neste caso, uma tradução tecnicamente correta do manual completo tem de estar disponível. O manual deve ser lido e entendido completamente antes da utilização do equipamento e todas as medidas necessárias devem ser aplicadas.  "Informação de Segurança para Equipamento que funciona a Vácuo"

## RO

Atentie: Acest manual nu este disponibil in toate limbile EU. Utilizatorul nu trebuie sa lucreze cu aparatul daca nu intelege manualul. Astfel, va fi disponibile o traducere corecta si completa a manualului. Manualul trebuie citit si inteles in intregime inainte de a lucra cu aparatul si a luat toate masurile care se impun.

 "Instrucțiuni de siguranță pentru aparatele de vidare"

## RU

Внимание: Эта инструкция по эксплуатации не имеется на всех языках. Потребителю не дозволено эксплуатировать данный прибор, если он не понимает эту инструкцию. В этом случае нужен технически правильный перевод полной инструкции. Прежде чем использовать этот прибор, необходимо полностью прочитать и понять эту инструкцию и принять все необходимые меры.  "Указания по технике безопасности при работе с вакуумными устройствами"

## SE

Varning: Denna instruktion är inte tillgänglig på alla språk inom EU. Användaren får inte starta utrustningen om hon/han inte förstår denna instruktion. Om så är fallet måste en tekniskt korrekt instruktion göras tillgänglig. Instruktionen måste läsas och förstås helt före utrustningen tas i drift och nödvändiga åtgärder göres.

 "Säkerhetsinformation för vakuumutrustning"

## SI

Pozor: Ta navodila niso na voljo v vseh jezikih EU. Uporabnik ne sme upravljati z napravo, če ne razume teh navodil. V primeru nerazumljivosti mora biti na voljo tehnično pravilen prevod. Navodila se morajo prebrati in razumeti pred uporaba naprave, opravljene pa moraja biti tudi vse potrebne meritve.

 "Varnostni nasveti za vakuumske naprave"

## SK

Upozornenie: Tento manuál nie je k dispozícii vo všetkých jazykoch EÚ. Užívateľ nesmie obsluhovať zariadenie, pokiaľ nerozumie tomuto manuálu. V takomto prípade musí byť k dispozícii technicky správny preklad celého manuálu. Pred obsluhou zariadenia je potrebné si prečítať celý manuál a porozumieť mu, a musia byť prijaté všetky opatrenia.  "Bezpečnostné pokyny pre vákuové zariadenia"

## TR

Dikkat : Bu kullanım kitabı, tüm dillerde mevcut değildir. Kullanıcı, bu kullanım kitabını anlayamadıysa cihazı çalıştırmamalıdır. Bu durumda, komple kullanım kitabının, teknik olarak düzgün çevirisinin bulunması gerekir. Cihazın çalıştırılmasından önce kullanım kitabının komple okunması ve anlaşılması ve tüm gerekli ölçümlerin uygulanması gerekir.  "Vakumlu cihazlar için güvenlik uyarıları"

# Contents

<b>Safety information!</b> .....	<b>9</b>
Important information! .....	9
General information .....	11
Intended use.....	11
Setting up and installing the equipment .....	12
Ambient conditions .....	14
Operating conditions .....	15
Safety during operation .....	17
Maintenance and repair.....	20
⚠ Important information: Equipment marking (ATEX) .....	22
<b>Technical data</b> .....	<b>24</b>
General technical data valid for all pumps/pumping units .....	24
Gas inlet temperatures .....	25
Wetted parts .....	28
Abbreviations.....	29
Pump parts .....	29
<b>Use and operation</b> .....	<b>38</b>
Installing a pump in a vacuum system .....	38
During operation.....	42
Important notes regarding the use of gas ballast .....	44
Important notes concerning the operation of the exhaust waste vapor condenser.....	45
Shutdown & storage.....	47
<b>Accessories</b> .....	<b>48</b>
<b>Troubleshooting</b> .....	<b>50</b>
<b>Replacing diaphragms and valves</b> .....	<b>52</b>
Cleaning and inspecting the pump heads .....	54
Replacing the diaphragm .....	58
Replacing the valves .....	60
Replacing the overpressure safety relief device.....	65
Replacing the fuse.....	66
<b>Notes on return to the factory</b> .....	<b>67</b>
<b>Warranty</b> .....	<b>70</b>
<b>EC Declaration of Conformity of the Machinery</b> .....	<b>72</b>

# Safety information!

## *Important information!*

### **! WARNING**

- ☞ Keep this manual complete and accessible to personnel at all times!
- ☞ Read this manual carefully before installing or operating the equipment. Observe the instructions contained in this manual.
- ☞ Do not modify the equipment without authorization.

### **NOTICE**

This manual is an integral part of the equipment described therein. It describes the safe and proper use of the vacuum pump.

Make operating personnel aware of dangers arising from the pump and the pumped substances.

**VACUUBRAND** disclaims any liability for inappropriate use of these pumps and for damage from failure to follow instructions contained in this manual.

This manual is only to be used and distributed in its complete and original form. It is strictly the users' responsibility to check carefully the validity of this manual with respect to his product.

Manual-no.: 999156 / 02/14/2012

**The following signal word panels and safety symbols are used throughout this manual:**



This is the safety alert symbol. It is used to alert you to potential personal injury hazards. Obey all safety messages that follow this symbol to avoid possible injury and death.



➔ DANGER indicates a hazardous situation which, if not avoided, will result in death or serious injury.



☞ WARNING indicates a hazardous situation which, if not avoided, could result in death or serious injury.



• CAUTION indicates a hazardous situation which, if not avoided, could result in minor or moderate injury.



NOTICE is used to address practices not related to personal injury.



Caution! Hot surface!



Disconnect equipment from AC power.

### Formatting used in this manual:

**Note:** The signal word panels in all sections of this manual always refer to all paragraphs of the same format (➔ / ☞ / • / plain text) following each signal word panel.

**The document "Safety information for vacuum equipment" is part of this manual! Read the "Safety information for vacuum equipment" and observe the instructions contained therein!**

## General information

### NOTICE

Remove all packing material from the packing box. Remove the product from its packing-box and retain all packaging until the equipment is inspected and tested. Remove the protective caps from the inlet and outlet ports and retain for future use. Inspect the equipment promptly and carefully.

If the equipment is damaged, notify the supplier and the carrier in writing within three days. Retain all packing material for inspection. State the item number of the product together with the order number and the supplier's invoice number. Failure to check and give notice of damage will void any and all warranty claims for those deficiencies.

Replace the protective caps, if the equipment is not used immediately. Store the equipment in dry and non-corrosive conditions (see also "Technical data", pg. 24).

### WARNING

☞ **Do not use any damaged equipment.**

### CAUTION

- Use the mounted handle when moving the pump.

## Intended use

### WARNING

- ☞ Do not use the pump or any system parts on humans or animals.
- ☞ Prevent any part of the human body from coming into contact with vacuum.
- ☞ Ensure that the individual components are only connected, combined and operated according to their design and as indicated in the instructions for use.
- ☞ Comply with all notes on correct vacuum and electrical connections; see section "Use and operation", pg. 38.
- ☞ Do not use the pump to generate pressure.
- ☞ The pumps are designed for **ambient temperatures** during operation between +50°F and +104°F (+10°C

and +40°C). Periodically check maximum temperatures if installing the pump in a cabinet or a housing. Make sure ventilation is adequate to maintain recommended operating temperature. Install an external automatic ventilation system if necessary. If pumping hot process gases, make sure that the maximum permitted gas inlet temperature is not exceeded. The maximum permitted gas inlet temperature depends on several parameters like inlet pressure and ambient temperature (see "Technical data", pg. 24).

- ☞ Do not aspirate particles and dust.
- ☞ Do not pump liquids.

### CAUTION

- Ensure that the pump is chemically resistant to the pumped substances prior to operation.

### NOTICE

Use the equipment **only as intended**, that is, for generation of vacuum in vessels designed for that purpose. Any other use will automatically invalidate all warranty and liability claims. Remain aware of safety and risks.

## *Setting up and installing the equipment*

### DANGER

- ➔ Equipment must be connected only to a **suitable electrical supply** and a suitable ground point. As such, the plug must be plugged into an outlet that is properly grounded. Failure to connect the motor to ground may result in deadly electrical shock.

The supply cable may be fitted with a molded European IEC plug or a plug suitable for your local electrical supply. The cable contains wires color coded as follows: green or green and yellow: ground; blue or white: neutral; brown or black: hot.

### WARNING

- ☞ Due to the high compression ratio, the pump may generate overpressure at the outlet. Check pressure compatibility with system components (e.g., exhaust pipeline or exhaust valve) at the outlet.

- ☞ Do not permit any **uncontrolled pressurizing**. Make sure that the exhaust pipeline cannot become blocked. If there is an exhaust isolation valve, make sure that you cannot operate the equipment with the valve closed to avoid a **risk of bursting!**
- ☞ Always provide a free and pressureless exhaust outlet to avoid damage to pump valves and risk of bursting of condenser glassware.
- ☞ Check the overpressure safety relief device at the exhaust waste vapor condenser at appropriate intervals.
- ☞ Keep the electrical power cord away from heated surfaces.



- Provide a firm, level platform for the equipment. Check that the system which you are going to evacuate is mechanically stable. Check that all fittings are secure. Ensure a stable position of the pump without any mechanical contact other than the pump feet.
- Comply with **maximum permissible pressures** at inlet and outlet and with **maximum permissible pressure differences** between inlet and outlet. See section "Technical data", pg. 24. Do not operate the pump with overpressure at the inlet.
- Avoid overpressure of more than 17.5 psi absolute (1.2 bar absolute) in the event that gas or inert gas is connected to the pump, to the gas ballast or to a venting valve.
- **Note:** Flexible elements will shrink when evacuated.
- Connect hoses gas tight at inlet and outlet of the pump.
- Ensure that no foreign objects can be drawn into the pump.
- Check the power source and the pump's rating plate to be sure that the power source and the equipment match in voltage, phase, and frequency.
- On pumps with a dual-voltage motor, check that the voltage selection switch is set correctly. Do not change the setting of the voltage selection switch while the

pump is connected to AC power. Unplug the pump before setting the voltage selection switch. **Note:** If the pump is switched on with wrong voltage selection, the motor may be damaged!

- Ensure that the **coolant outlet pipe** is always free and that it cannot get blocked. If installing an optional coolant valve, it must always be in the supply line of the exhaust waste vapor condenser.

## NOTICE

Keep a minimum distance of 8 in (20 cm) between the cooling fan and surrounding items (e.g., housing, walls, etc.). Check fan regularly for dust/dirt. Clean fan guard grill if necessary to avoid a reduction of ventilation.

Use only hoses at the inlet and outlet of the pump with an inner diameter at least as large as the diameter of the pump's tubing (to avoid overpressure at the outlet, and reduction of pumping speed at the inlet).

Allow the equipment to equilibrate to ambient temperature if you bring it from cold environment into a room prior to operation. Notice if there is water condensation on cold surfaces.

Secure coolant hoses at the hose nozzles (e.g., with hose clamp) to prevent their accidental slipping.

Comply with all **applicable and relevant safety requirements** (regulations and guidelines). **Implement the required actions and adopt suitable safety measures.**

## *Ambient conditions*

### DANGER

- ➔ Do not reach for this product if it has fallen into liquid. There is a risk of deadly electrical shock. Unplug the system immediately.

### WARNING

- ☞ Do not use this product in an area where it can fall or be pulled into water or other liquids.

- ☞ Pay attention to the **permissible maximum ambient and gas inlet temperatures** (see "Technical data", pg. 24).

## CAUTION

- Adopt suitable measures in case of differences from recommended conditions, e.g., using the equipment outdoors, installation in altitudes of more than 3300 ft (1000 m) above mean sea level, conductive pollution or external condensation on the pump.
- Do not operate this product near flames.

## NOTICE

To the best of our knowledge the equipment is in compliance with the requirements of the applicable EC-directives and harmonized standards (see "Declaration of Conformity") with regard to design, type and model. Directive EN 61010-1 gives in detail the conditions under which the equipment can be operated safely (see also IP degree of protection, "Technical data", pg. 24).

## Operating conditions

## DANGER

- ➔ These pumps are not approved for operation in potentially explosive atmospheres. **Do not operate the pumps in potentially explosive atmospheres.**
- ➔ Pumps **without the "Ex" mark on the rating plate are not approved for the pumping of potentially explosive atmospheres. Do not pump potentially explosive atmospheres** with those pumps.
- ➔ Pumps **bearing the "Ex" mark on their rating plates are approved for the pumping of potentially explosive atmospheres** according to their classification **II 3G IIC T3 X** according to ATEX, but they are **not approved for operation in potentially explosive atmospheres** (see section "Ex Important information: Equipment marking (ATEX)", pg. 22).
- ➔ The pumps are **not suitable** to pump any of the substances listed below.  
**Do not pump:**

- **unstable substances**
- substances which react explosively under **impact** (mechanical stress) without air
- substances which react explosively when being exposed to **elevated temperatures** without air,
- substances subject to **auto-ignition**,
- substances which are **flammable without air**
- **explosive substances**.

➔ The pumps are **not approved** for operation below ground. **Do not operate** the pump **below ground**.



☞ The pumps are **not suitable** for pumping dust. **Do not pump dust**.



- **Do not pump** substances which may form **deposits** inside the pump. The pumps are not suitable for pumping substances which may form deposits inside the pump. Deposits and condensate in the pump may lead to increased temperatures even to the point of exceeding the maximum permitted temperatures.
- Check the inlet and outlet of the pump, if there is a danger of forming **deposits** inside the pump, e.g., in the pump chambers (the pump chamber is the part between diaphragm and head cover. See section "Replacing diaphragms and valves", pg. 52). Inspect the pump chambers regularly and clean if necessary.
- **Consider interactions and chemical reactions of the pumped media.** Ensure that the materials of the pump's wetted parts are compatible with the pumped substances, see section "Technical data", pg. 24. When changing the substances pumped, we recommend purging the pump with air or inert gas prior to changing the pumped media. Purging the pump will pump out residues and it will reduce the possibility of reactions of the pumped substances with each other and with the pump's materials.

## ***Safety during operation***

### **! DANGER**

- ➔ Adopt suitable measures to prevent the release of dangerous, toxic, explosive, corrosive, noxious or polluting fluids, vapors and gases. To prevent any emission of such substances from the pump outlet, install an appropriate collecting and disposal system and take protective action for pump and environment.
- ➔ You must take suitable precautions to prevent any formation of explosive mixtures in the pump chamber or at the outlet of the pump. In case, e.g., of a diaphragm failure, mechanically generated sparks, hot surfaces or static electricity may ignite these mixtures. Use inert gas for gas ballast or venting, if necessary.
- ➔ Drain appropriately or otherwise remove any potentially explosive mixtures at the outlet of the pump, or dilute them with inert gas to non-explosive concentrations.
- ➔ Never operate this pump if it has a damaged cord or plug.

### **! WARNING**

- ☞ If the pump is not working properly, has been dropped or has fallen into water, contact your pump service provider.
- ☞ Prevent any part of the human body from coming into contact with vacuum.
- ☞ Never aspirate liquids or dust into the pump.
- ☞ Make sure that the exhaust pipeline cannot become blocked.
- ☞ Check the overpressure safety relief device at the exhaust waste vapor condenser at appropriate intervals.
- ☞ Comply with applicable regulations when disposing of chemicals. Take into consideration that chemicals may be contaminated. Take adequate precautions to protect people from the effects of dangerous substances (chemicals, thermal decomposition products of fluo-

roelastomers). Use appropriate protective clothing and safety goggles.

- ☞ Use only **original manufacturer's spare parts and accessories**. Otherwise the safety and performance of the equipment, as well as the electromagnetic compatibility of the equipment might be reduced.  
The CE mark or the cTÜVus mark may be voided if not using original manufacturer's spare parts.
- ☞ Interruption of the pump (e.g., due to power failure), failure of connected components or of parts of the supply, or change in parameters must not be allowed to lead to dangerous conditions. In case of a diaphragm failure or in case of a leak in the manifold, pumped substances might be released into the environment or into the pump housing or motor.  
Comply with all notes regarding proper use of the pumps, as well as operation and maintenance guidance.
- ☞ The residual **leak rate of the equipment** might render possible an exchange of gas, albeit extremely slight, between the environment and the vacuum system.  
Adopt suitable measures to prevent contamination of the pumped substances or the environment.

 **CAUTION**

- Ensure that no parts of your clothing, hair or fingers can be caught or drawn in at the inlet of the pump. Never insert fingers or drop any other object into the inlet or outlet.
- Pumping at high inlet pressure may lead to overpressure at the gas ballast valve. Pumped gases or condensate might be expelled if the valve is open. If an inert gas supply is connected to the gas ballast, ensure that its inlet pipeline is not contaminated.
- Pay attention to the safety symbol "hot surfaces" on the equipment. Hot parts may cause burns if touched. Adopt suitable measures to prevent any danger arising



from hot surfaces or electric sparks. Ensure that hot surfaces of the pump do not cause burns. Provide a suitable contact guard if necessary.

- Ensure that the **coolant outlet pipe** at the waste vapor condenser is always free and that it cannot get blocked.

## NOTICE

Do not start the pump if the pressure difference between inlet and outlet exceeds 16 psi (1.1 bar) at maximum. Prevent the backpressure of gases and the backflow of condensates at the outlet.

Check the liquid level in the catchpots regularly and drain condensate in time to prevent overflowing. Install a level sensor (see "Accessories", pg. 48) for monitoring, if necessary.

Provide appropriate protective measures to allow for the possibility of failure and **malfunction**. The protective measures must also allow for the requirements of the respective application.

In case of overload, the motor is shut down by a **self-hold thermal cutout** in the winding.

**Note:** Only manual reset is possible. Switch off the pump and disconnect from the power source. Identify and eliminate the cause of failure. Wait approx. five minutes before restarting the pump.

## CAUTION

- **Note:** In case of **supply voltage below 100V**, the lock of the cutout might be impaired and the pump may restart on its own after sufficient cooling down. Take appropriate precautions, if an automatic restart of the pump may lead to a dangerous situation (e.g., switch off the pump and disconnect from the power source).

## ***Maintenance and repair***

### **NOTICE**

In order to comply with laws (occupational, health and safety regulations, safety at work law and regulations for environmental protection) vacuum pumps, components and measuring instruments can only be returned when certain procedures (see section "**Notes on return to the factory**", pg. 67) are followed.

Take advantage of our service seminars, which put special focus on the maintenance and repair of vacuum pumps. For details and for the online "Instructions for repair" manual see [www.vacuubrand.com](http://www.vacuubrand.com).

In case of normal wear, the lifetime of the diaphragms and valves is > 10000 operating hours. Bearings have a typical durability of 40000 h. Motor capacitors have a typical durability in the range of 10000 to 40000 h depending strongly on operation conditions including ambient temperature, humidity or load.

### **! DANGER**



- ➔ **Ensure that the pump cannot be operated accidentally. Never operate the pump if covers or other parts of the pump are disassembled.**
- ➔ **Switch off the pump. Disconnect the electrical power cord and wait two minutes** before starting maintenance to allow the capacitors to discharge.

- ➔ **Note:** The pump may be contaminated with process chemicals, which have been pumped during operation. Ensure that the pump is completely decontaminated before maintenance commences.

### **! WARNING**

- ☞ Take adequate precautions to protect people from the effects of dangerous substances if contamination has occurred. Use appropriate protective clothing, safety goggles and protective gloves.

- ☞ **Wear parts have to be replaced regularly.**
- ☞ **Never operate a defective or damaged pump.**
  
- ☞ Check every motor capacitor regularly by measuring its capacity and estimating its time in operation. Replace old capacitors early enough to prevent a failure in operation. If an old motor capacitor fails, the capacitor may get hot. It may even melt or emit a flame, which could be **dangerous for persons and equipment in the vicinity**. The capacitors have to be replaced by an electrician.
  
- ☞ Vent the pump before starting maintenance. Isolate the pump and other components from the vacuum system. Allow sufficient cooling of the pump. Separate the pump from the coolant circuit and drain condensate, if applicable.

**NOTICE**

Ensure that **maintenance** is done only by suitably trained and supervised technicians. Ensure that the maintenance technician is familiar with the safety procedures, which relate to the products processed by the pumping system. Only dismantle the pump as far as necessary.

**⊕ Ex** *Important information: Equipment marking (ATEX)***VACUUBRAND equipment bearing mark (see rating plate)**

**⊕ Ex II 3G IIC T3 X**  
**Internal Atm. only**  
**Tech. File Ref.: VAC-EX01**

**and**

**VACUUBRAND equipment bearing mark (see rating plate)**

**⊕ Ex X see manual**

For equipment labelled with „⊕ Ex X see manual“ the following classification according to Directive 94/9/EC (ATEX) is valid: ⊕ Ex II 3G IIC T3 X, Internal Atm. only, Tech. File Ref.: VAC-EX01.

The classification II 3G IIC T3 X according to ATEX is only valid for the inner part (wetted part, pumped gas or vapor) of the equipment. The equipment is not suitable for use in external, potentially explosive atmospheres (environment).

The overall category of the equipment depends on the connected components. If the connected components do not comply with the classification of the VACUUBRAND equipment, the specified category of the VACUUBRAND equipment is no longer valid.

Vacuum pumps and vacuum gauges in category 3 are intended for connection at equipment in which during normal operation explosive atmospheres caused by gases, vapors or mists normally don't occur or, if they do occur, are likely to do so only infrequently and for a short period only. Equipment in this category ensures the requisite level of protection during normal operation.

The use of gas ballast or the operation of venting valves is only permitted if thereby explosive atmospheres normally don't occur in the interior of the equipment or, if they do occur, are likely to do so only infrequently and for a short period.

The pumps are marked with "X" (according to EN 13463-1), i. e. restrictions of the operation conditions:

- The equipment is designated for a low degree of mechanical stress and has to be installed in a way so that it cannot be damaged from outside.  
Pumping units have to be installed protected against shocks from the outside and against glass splinters in the event of breaking (implosion).
- The equipment is designated for an ambient and gas inlet temperature during operation of +10 to +40°C. Never exceed these ambient and gas inlet temperatures. If pumping / measuring gases which are not potentially explosive, extended gas inlet temperatures are valid, see instructions for use, section "Gas inlet temperatures" or "Technical data".

After any intervention at the equipment (e.g., repair / maintenance) the ultimate vacuum of the pump has to be checked. Only if the pump achieves its specified ultimate vacuum, the pump's leak rate is low enough to ensure that no explosive atmospheres will occur in the interior of the equipment.

After any intervention at the vacuum sensor the leak rate of the equipment has to be checked.



**Attention: This manual is not available in all languages of the EU. The user must not operate the device if he does not understand this manual. In this case a technically correct translation of the complete manual has to be available. The manual must be completely read and understood before operation of the device and all required measures must be applied.**

# Technical data

<b>General technical data valid for all pumps/pumping units</b>		
Maximum permissible inlet pressure (absolute)	psi (bar)	16 (1.1)
Maximum permissible outlet pressure (absolute)	psi (bar)	16 (1.1)
Maximum pressure difference between inlet and outlet	psi (bar)	16 (1.1)
Maximum permissible pressure (absolute) at gas ballast valve	psi (bar)	17.5 (1.2)
Permissible ambient temperature storage / operation	°F (°C)	14 to 140 / 50 to 104 (-10 to +60 / +10 to +40)
Permissible relative atmospheric moisture during operation (no condensation)	%	30 to 85
No-load speed 50/60 Hz	rpm	1500 / 1800
Device fuse		slow blow fuse 6.3 A
Motor protection		thermal cutout, manual reset
Degree of protection IEC 529		IP 40
Coolant connection (waste vapor condenser, only "EK")		hose nozzle for tubing I.D. 1/4" - 5/16" (hose nozzle DN 6-8 mm)
Maximum permissible pressure of coolant at waste vapor condenser ("EK")	psi (bar)	87 (absolute) (6 (absolute))
Permissible range of coolant temperature (waste vapor condenser, only "EK")	°F (°C)	5 to 68 (-15 to +20)
Volume of catchpot (only "AK" / "EK")	quarts (ml)	0.52 (500)
A-weighted emission sound pressure level* (uncertainty $K_{pA}$ : 3 dB(A))	dB(A)	45

\* Measurement according to EN ISO 2151:2004 and EN ISO 3744:1995 at 230V/50Hz and ultimate vacuum with exhaust tube at outlet.

## Gas inlet temperatures

Operating condition	Inlet pressure	Permitted range of gas temperatures at inlet
Continuous operation	> 75 Torr (100 mbar) (high gas load)	➔ 50 °F to 104 °F (+10°C to +40°C)
Continuous operation	< 75 Torr (100 mbar) (low gas load)	➔ 32 °F to 140 °F* (0°C to +60°C*)
Short-time (< 5 minutes)	< 75 Torr (100 mbar) (low gas load)	➔ 14 °F to 176 °F* (-10°C to +80°C*)

\* if pumping potentially explosive atmospheres: 50 °F to 104 °F (+10°C to +40°C)

Type		ME 2C NT	ME 4C NT ME 4C NT + 2 AK
Maximum pumping speed* 50/60 Hz (ISO 21360)	cfm (m <sup>3</sup> /h)	1.2 / 1.4 (2.1 / 2.4)	2.3 / 2.6 (3.9 / 4.3)
Ultimate vacuum (absolute)	Torr (mbar)	52.5 (70)	52.5 (70)
Rated motor power	hp (kW)	0.24 (0.18)	
Maximum permissible range of supply voltage ( ±10% ) Attention: Observe specifications of rating plate!		100-115 V~ 50/60 Hz, 120V~ 60 Hz 230 V~ 50/60 Hz	
Dual voltage motor		100-115 V~ 50/60 Hz, 120~ V 60 Hz / 200-230 V~ 50/60 Hz	
Maximum rated current at:	A	3.4	
100-115 V~ 50/60 Hz,	A	1.8	
120 V~ 60 Hz	A	1.8	
200-230 V~ 50/60 Hz	A		
230 V~ 50/60 Hz	A		
Inlet		hose nozzle for tubing I.D. 3/8" or small flange KF 16 (hose nozzle DN 10 mm or small flange KF 16)	
Outlet		hose nozzle for tubing I.D. 3/8" (hose nozzle DN 10 mm)	
Dimensions L x W x H approx. design 2 AK	in (mm) in (mm)	9.6 x 8.3 x 7.8 (243 x 211 x 198) - (-)	10.0 x 9.6 x 7.8 (254 x 243 x 198) 12.4 x 9.6 x 11.5 (316 x 243 x 291)
Weight approx. design 2 AK	lbs. (kg) lbs. (kg)	22.5 (10.2) -	24.3 (11.1) 30.0 (13.6)

\* Pumping speed of diaphragm pump

Type		<b>MZ 2C NT</b> <b>MZ 2C NT + 2 AK</b> <b>MZ 2C NT + AK + EK</b> <b>MZ 2C NT + AK SYNCHRO + EK</b> <b>MZ 2C NT + AK + M + D</b> <b>PC 101 NT</b>
Maximum pumping speed* 50/60 Hz (ISO 21360)	cfm (m <sup>3</sup> /h)	1.2 / 1.4 (2.0 / 2.3)
Ultimate vacuum (absolute) without gas ballast	Torr (mbar)	5.3 (7)
Ultimate vacuum (absolute) with gas ballast	Torr (mbar)	9 (12)
Rated motor power	hp (kW)	0.24 (0.18)
Maximum permissible range of supply voltage ( ±10% ) Attention: Observe specifications of rating plate!  Dual voltage motor		100-115 V~ 50/60 Hz, 120V~ 60 Hz  230 V~ 50/60 Hz  100-115 V~ 50/60 Hz, 120 V 60 Hz / 200-230 V~ 50/60 Hz
Maximum rated current at: 100-115 V~ 50/60 Hz, 120 V~ 60 Hz 200-230 V~ 50/60 Hz 230 V~ 50/60 Hz	A  A A	3.4  1.8 1.8
Inlet		hose nozzle for tubing I.D. 3/8" or small flange KF 16 (hose nozzle DN 10 mm or small flange KF 16)
Outlet		hose nozzle for tubing I.D. 3/8" (hose nozzle DN 10 mm)
Dimensions L x W x H approx. Pump: Vacuum systems: design 2 AK design AK + EK design AK SYNCHRO + EK design AK + M + D PC 101 NT	in (mm)  in (mm) in (mm) in (mm) in (mm)	9.6 x 9.6 x 7.8 (243 x 243 x 198)  12.6 x 9.6 x 12.2 (319 x 243 x 309) 12.8 x 9.6 x 15.8 (326 x 243 x 402) 12.8 x 9.8 x 15.8 (326 x 248 x 402) 12.2 x 9.6 x 12.3 (310 x 243 x 313) 12.8 x 9.6 x 15.8 (326 x 243 x 402)
Weight approx. Pump: Vacuum systems: design 2 AK design AK + EK design AK SYNCHRO + EK design AK + M + D PC 101 NT	lbs. (kg)  lbs. (kg) lbs. (kg) lbs. (kg) lbs. (kg)	24.3 (11.1)  30.0 (13.6) 31.3 (14.2) 32.0 (14.5) 29.5 (13.4) 32.0 (14.5)

\* Pumping speed of diaphragm pump

Type	ME 8C NT		MD 4C NT MD 4C NT + 2 AK MD 4C NT + AK + EK MD 4C NT + AK SYNCHRO + EK PC 201 NT
	ME 8C NT + 2 AK		
Maximum pumping speed* 50/60 Hz (ISO 21360)	cfm (m <sup>3</sup> /h)	4.0 / 4.6 (7.1 / 7.8)	2.0 / 2.2 (3.4 / 3.8)
Ultimate vacuum (absolute) without gas ballast	Torr (mbar)	52.5 (70)	1.1 (1.5)
Ultimate vacuum (absolute) with gas ballast	Torr (mbar)	-	2.3 (3)
Rated motor power	hp (kW)	0.34 (0.25)	
Maximum permissible range of supply voltage ( ±10% ) Note: Observe specifications of rating plate!		100 V~ 50/60 Hz  120 V~ 60 Hz	100-115 V~ 50/60Hz, 120 V~ 60 Hz  - 230 V~ 50/60 Hz
Dual voltage motor		100-115 V~ 50/60 Hz, 120 V~ 60 Hz / 200-230 V~ 50/60 Hz	
Maximum rated current at:	A	5.0	
100 V~ 50/60 Hz	A	4.0	
120 V~ 60 Hz	A	5.7	
100-115 V~ 50/60 Hz, 120V~ 60 Hz	A	3.0	
200-230 V~ 50/60 Hz	A	3.0	
230V~ 50/60 Hz	A		
Inlet		hose nozzle for tubing I.D. 3/8" (hose nozzle DN 10 mm)	
Outlet		hose nozzle for tubing I.D. 3/8" (hose nozzle DN 10 mm)	
Dimensions L x W x H approx. Pump:	in (mm)	12.8 x 9.6 x 7.8 (325 x 243 x 198)	12.8 x 9.6 x 7.8 (325 x 243 x 198)
Vacuum systems: design 2 AK	in (mm)	12.6 x 9.6 x 14.7 (319 x 243 x 374)	12.6 x 9.6 x 14.7 (319 x 243 x 374)
design AK + EK	in (mm)	-	12.8 x 9.6 x 15.8 (326 x 243 x 402)
design AK SYNCHRO + EK	in (mm)	-	12.8 x 9.8 x 15.8 (326 x 248 x 402)
PC 201 NT	in (mm)	-	12.8 x 9.6 x 15.8 (326 x 243 x 402)

\* Pumping speed of diaphragm pump

Type		ME 8C NT	MD 4C NT
		ME 8C NT + 2 AK	MD 4C NT + 2 AK MD 4C NT + AK + EK MD 4C NT + AK SYNCHRO + EK PC 201 NT
Weight approx.			
Pump:	lbs. (kg)	31.5 (14.3)	31.5 (14.3)
Vacuum systems:			
design 2 AK	lbs. (kg)	36.8 (16.7)	36.8 (16.7)
design AK + EK	lbs. (kg)	-	38.1 (17.3)
design			
AK SYNCHRO + EK	lbs. (kg)	-	38.8 (17.6)
PC 201 NT	lbs. (kg)	-	38.6 (17.5)

## Wetted parts

Components	Wetted materials
Head cover	ETFE carbon fiber reinforced
Diaphragm clamping disc	ETFE carbon fiber reinforced
Diaphragm	PTFE
Valves (ME 2C NT / ME 4C NT / ME 8C NT)	PTFE
Valves (MZ 2C NT / MD 4C NT)	FFKM
O-rings	FPM
Valve head	ECTFE carbon fiber reinforced
Gas ballast tube	PTFE carbon reinforced
Inlet (hose nozzle) Pump Vacuum systems Inlet (small flange)	PTFE carbon reinforced PP (PBT only SYNCHRO designs) stainless steel
Outlet (hose nozzle) Pump / MZ 2C NT + AK + M + D Vacuum systems (waste vapor condenser) Vacuum systems (2 AK)	PTFE carbon reinforced PET PP
Tubing	PTFE
Flow control diaphragm	PTFE
Valve block (SYNCHRO design)	PP
Valves (valve block SYNCHRO)	FFKM
Distribution head	PPS glass fiber reinforced
Blind plug	PP
O-ring at catchpot	FPM
Overpressure safety relief device	PTFE / silicone rubber
Exhaust waste vapor condenser / catchpot	Borosilicate glass

## Abbreviations

<b>ETFE:</b>	Ethylene/Tetrafluoroethylene
<b>PTFE:</b>	Polytetrafluoroethylene
<b>FFKM:</b>	Perfluoro elastomer
<b>FPM:</b>	Fluoroelastomer
<b>ECTFE:</b>	Ethylene/Chlorotrifluoroethylene
<b>PP:</b>	Polypropylene
<b>PBT:</b>	Polybutylene terephthalate
<b>PET:</b>	Polyethylene terephthalate
<b>PPS:</b>	Polyphenylene sulfide
<b>AK:</b>	separator for condensates, catchpot at inlet or outlet
<b>EK:</b>	exhaust vapor condenser

## Pump parts

Position	Component
1	Inlet
2	Outlet
3	Gas ballast valve
4	ON/OFF switch
5	Mains connection
6	Handle
7	Pump rating plate
8	Fan
9	Catchpot
10	Exhaust waste vapor condenser

Position	Component
11	Overpressure safety relief device
12	Coolant inlet
13	Coolant outlet
14	Flow control diaphragm
15	Manometer
16	Valve block
17	Distribution head
18	Blind plug
19	Voltage selection switch
20	Pump support

**We reserve the right for technical modification without prior notice!**

# ME 2C NT

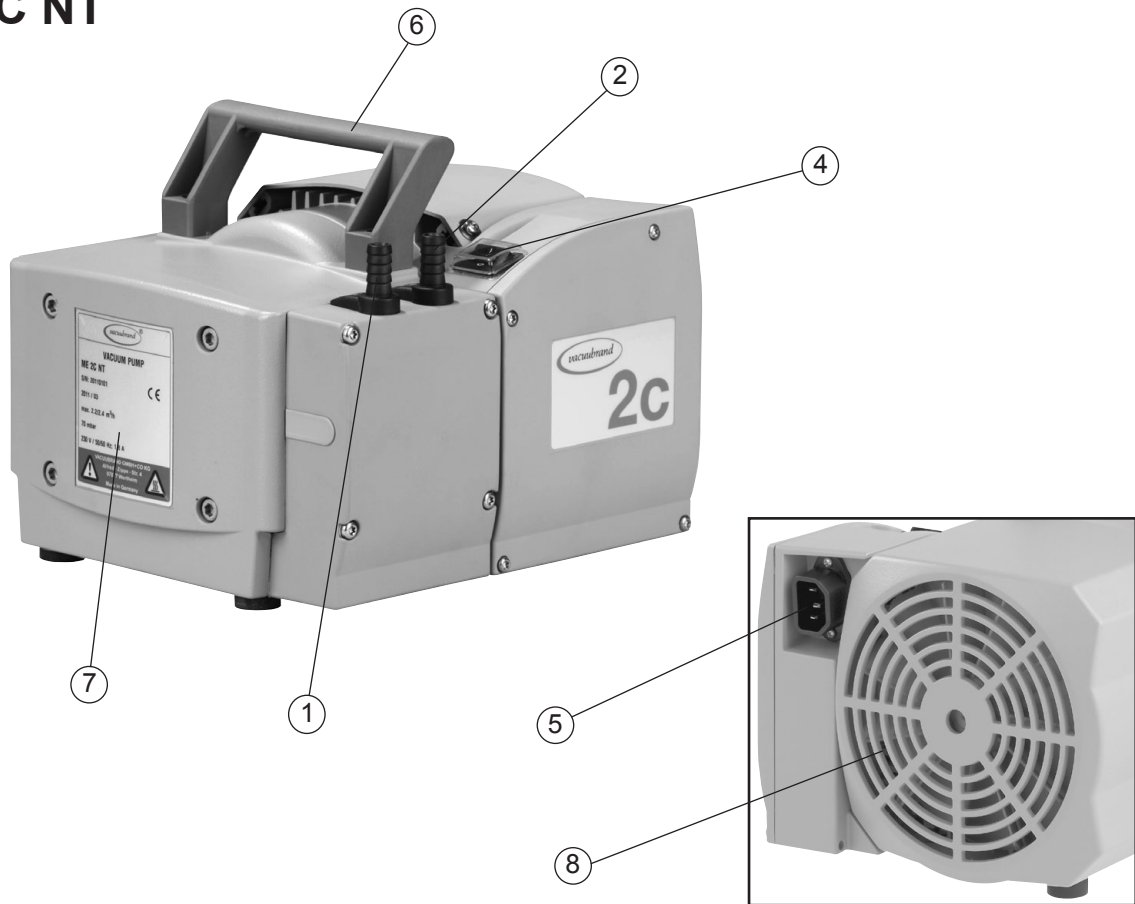

# ME 4C NT

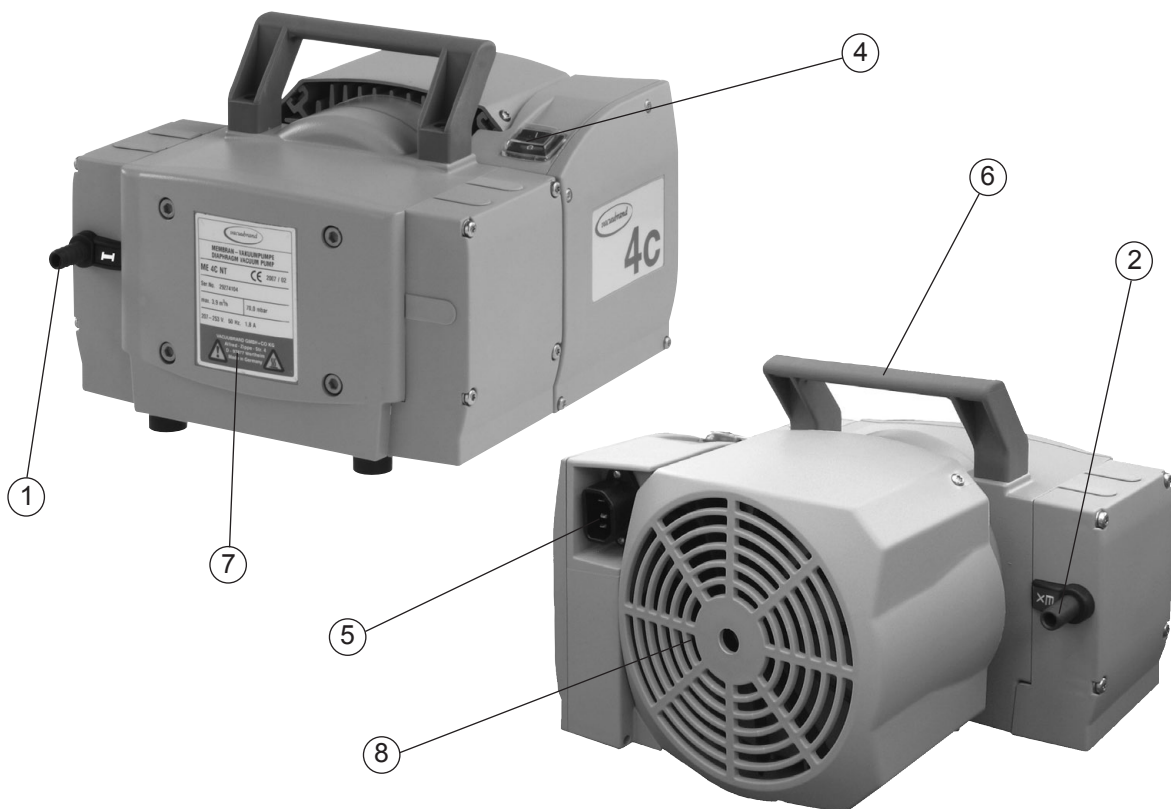

## ME 4C NT + 2 AK

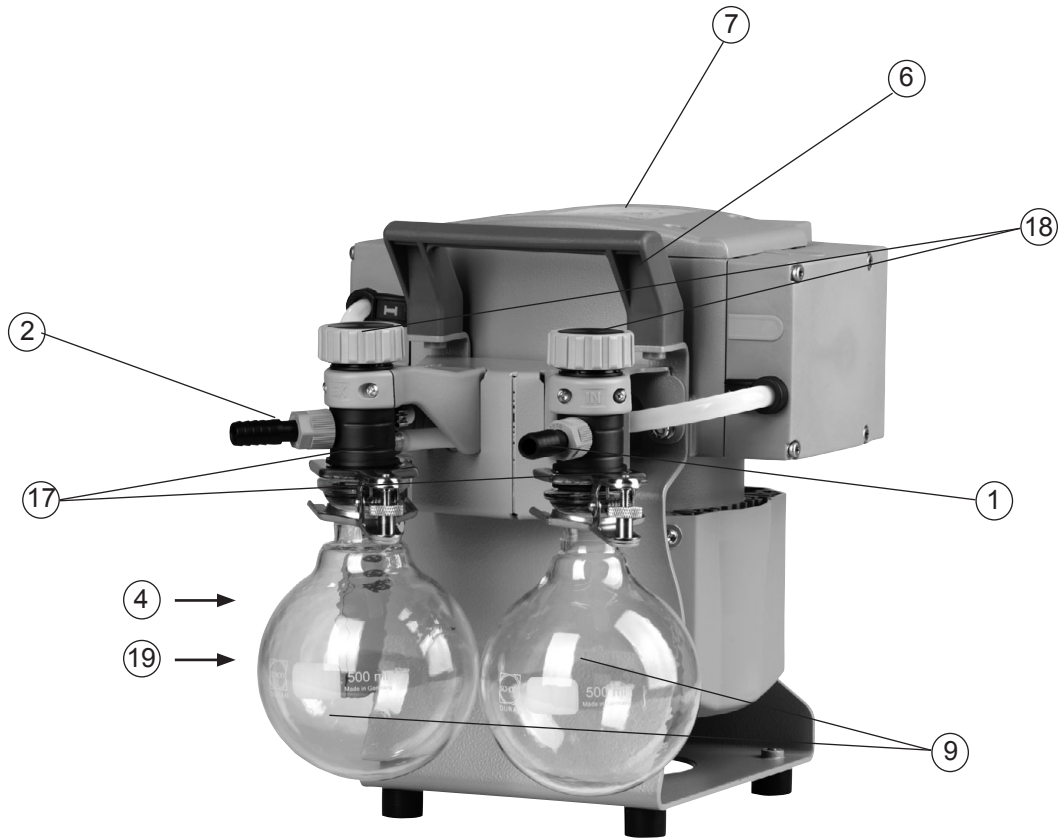

Power connection: see ME 4C NT

## MZ 2C NT

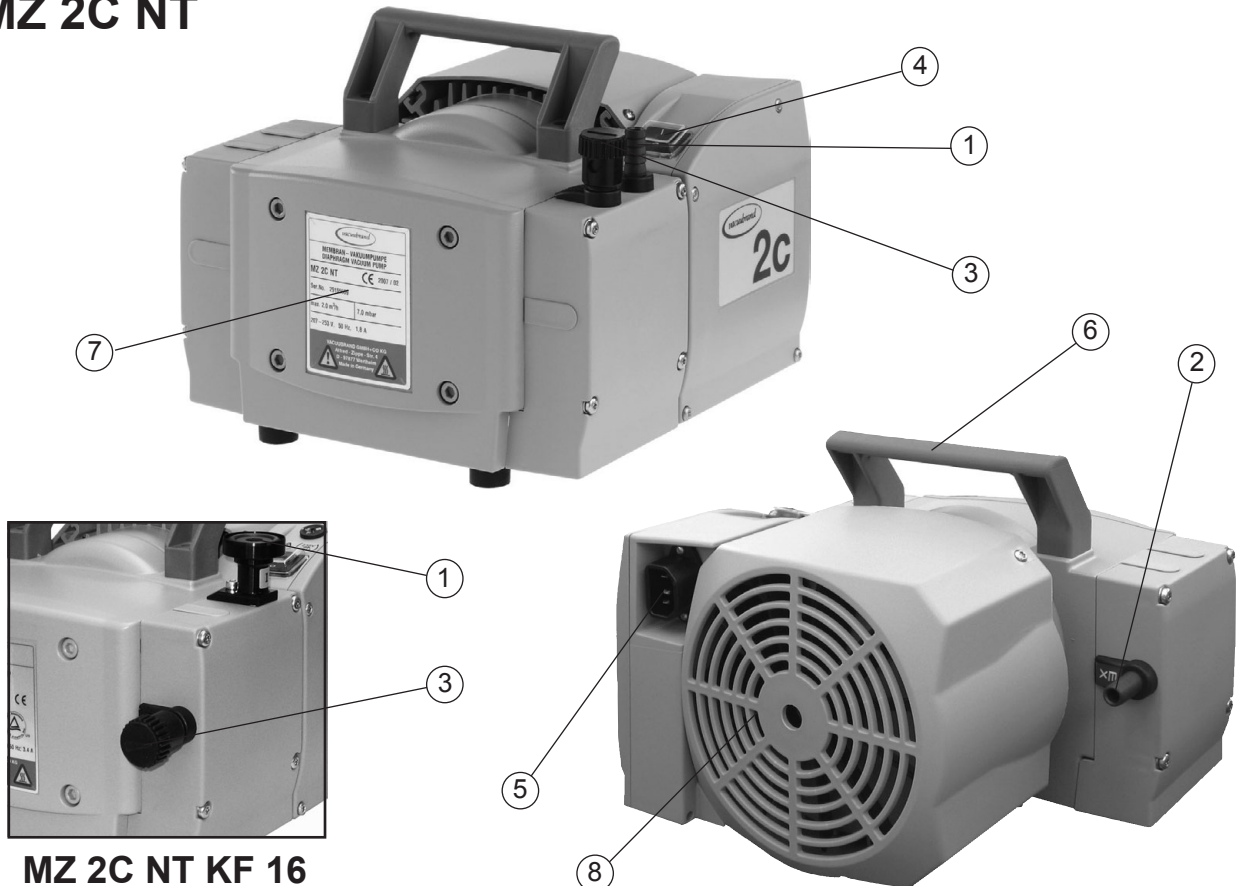

MZ 2C NT KF 16

# ME 8C NT

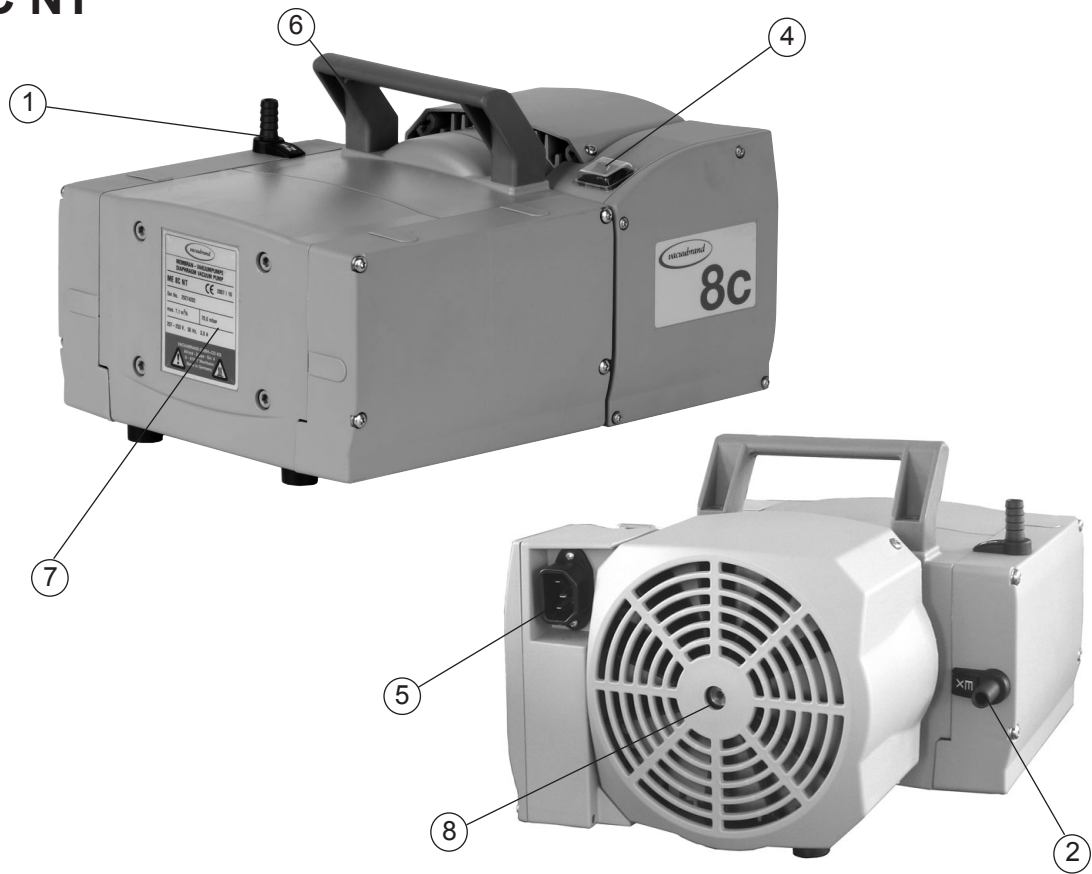

# MD 4C NT

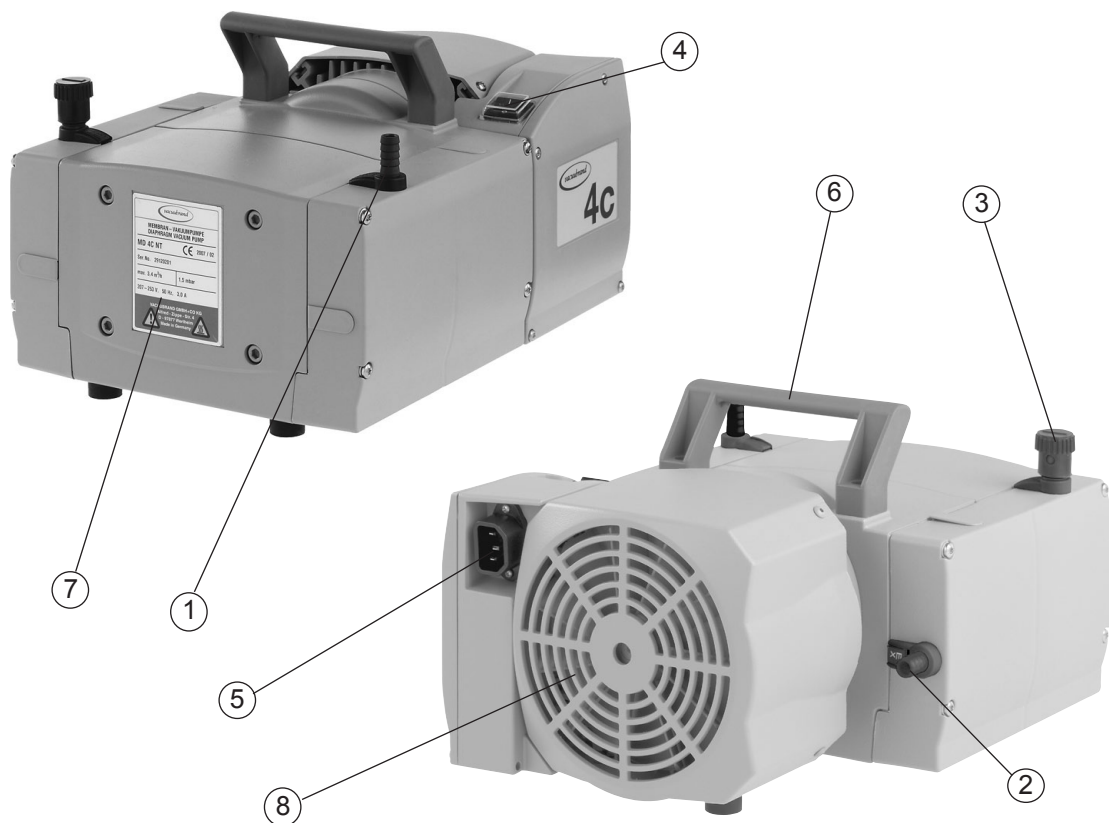

### MZ 2C NT + 2 AK

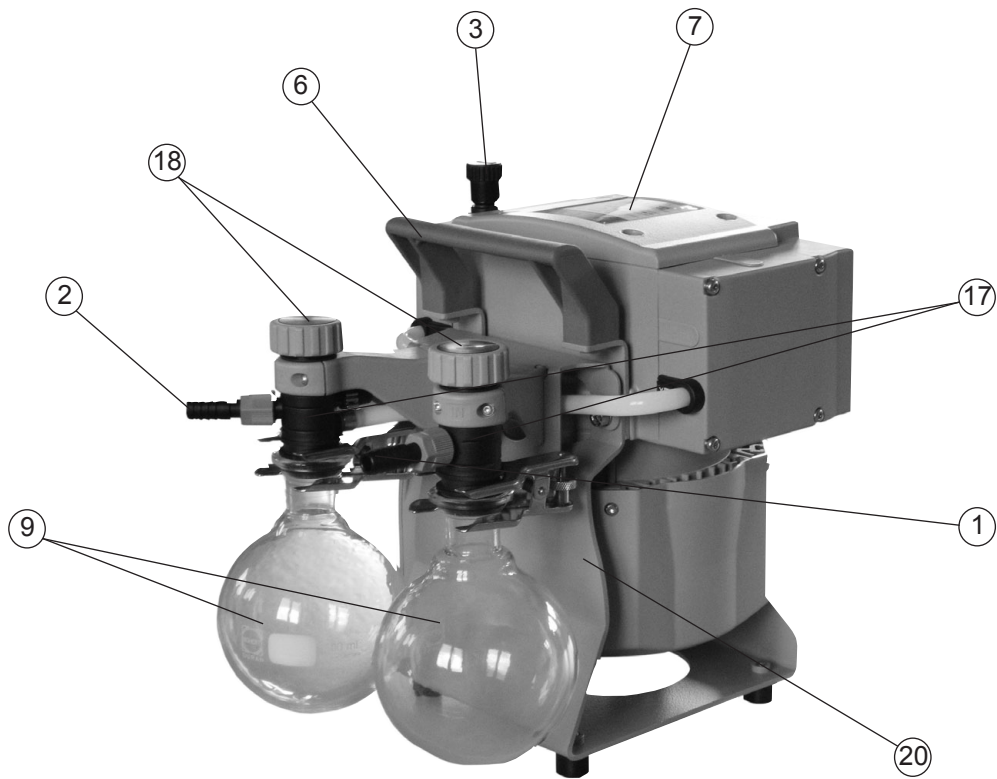

**Power connection and ON/OFF switch: see MZ 2C NT**

### MZ 2C NT + AK + EK

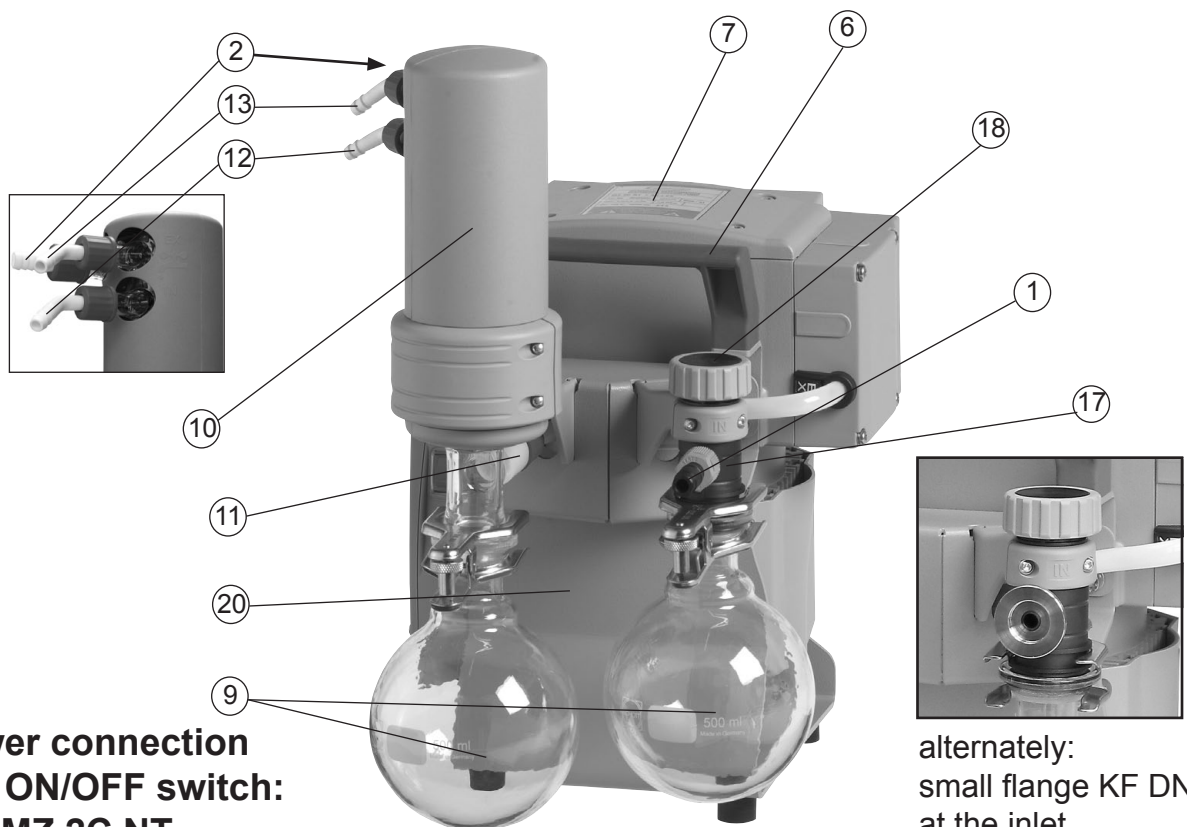

**Power connection and ON/OFF switch: see MZ 2C NT**

alternately:  
small flange KF DN 16  
at the inlet

### MZ 2C NT + AK SYNCHRO + EK

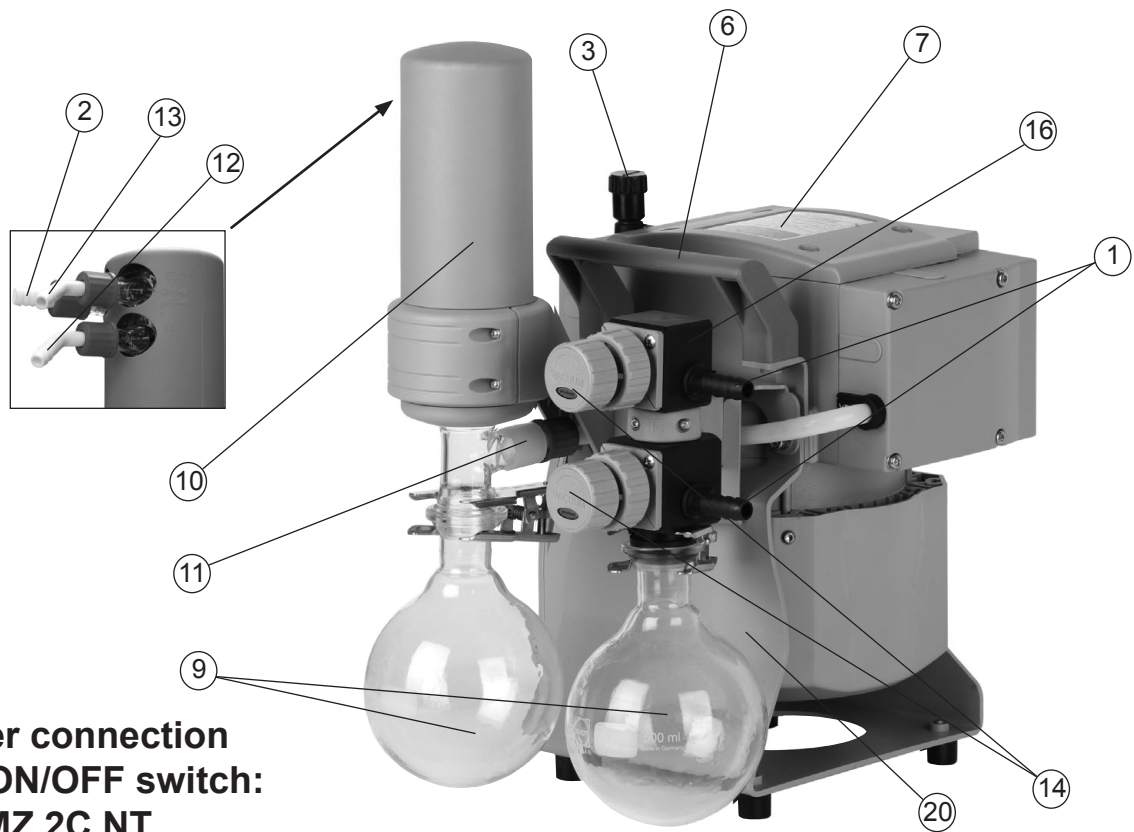

**Power connection and ON/OFF switch: see MZ 2C NT**

### MZ 2C NT + AK + M + D

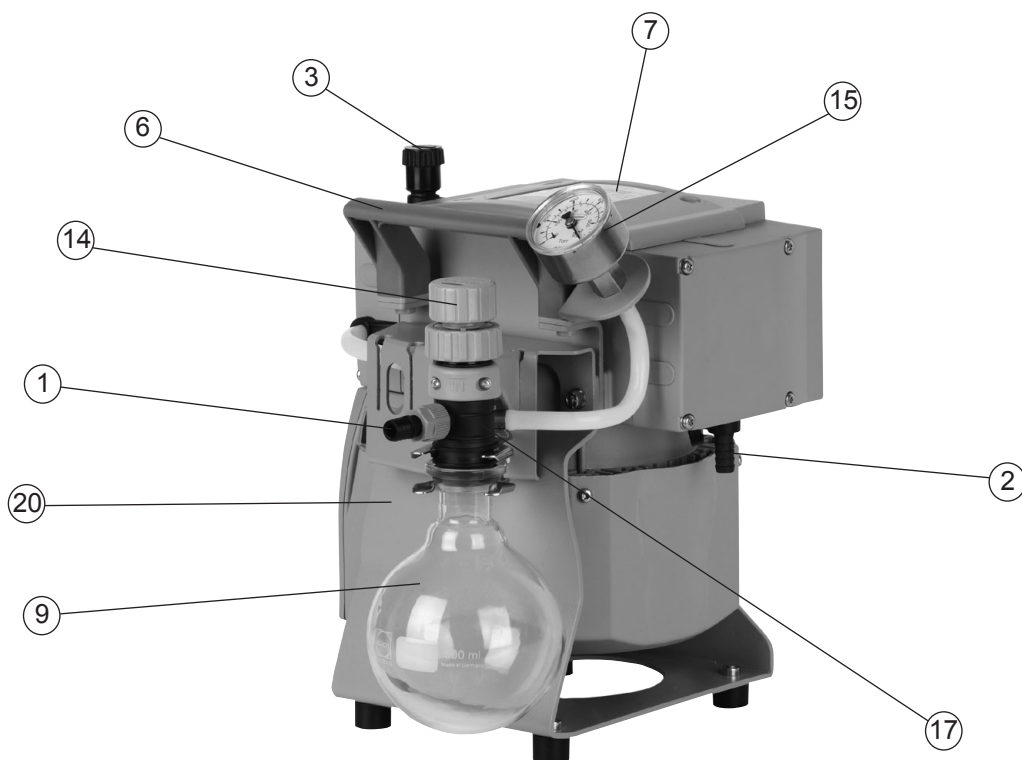

**Power connection and ON/OFF switch: see MZ 2C NT**

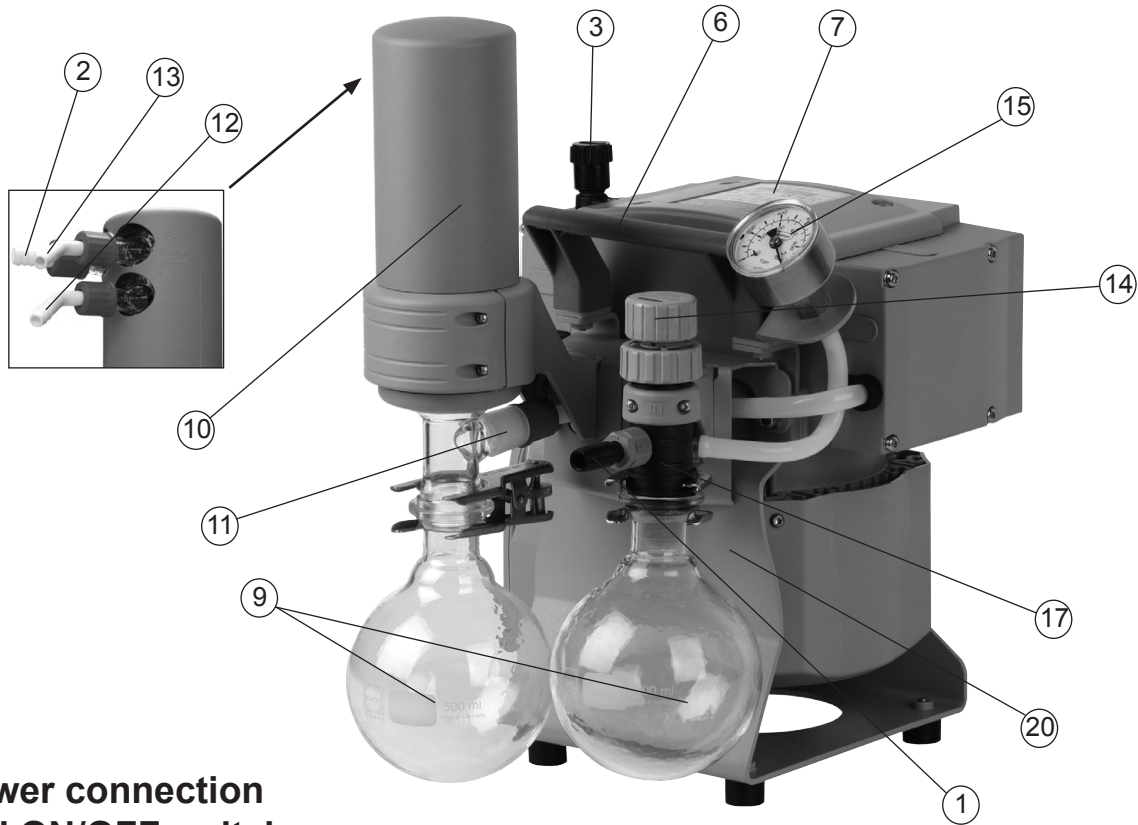
**PC 101 NT**

**Power connection  
and ON/OFF switch:  
see MZ 2C NT**

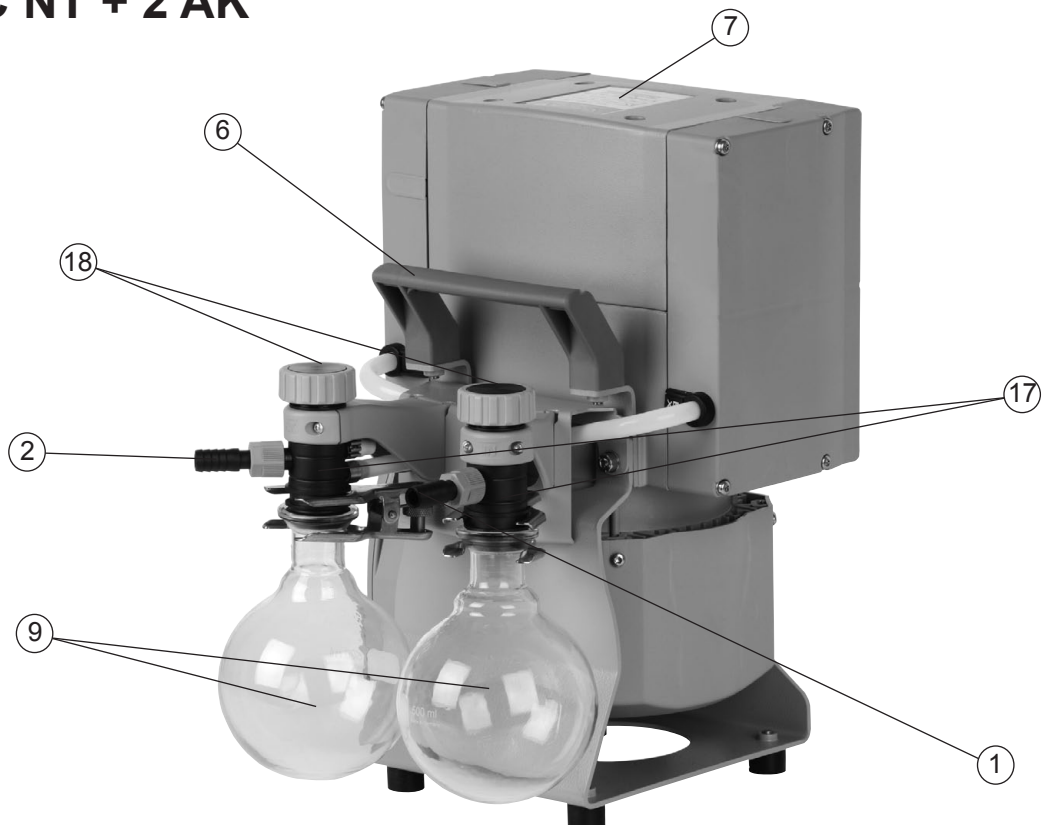
**ME 8C NT + 2 AK**

**Power connection and ON/OFF switch: see ME 8C NT**

### MD 4C NT + 2 AK

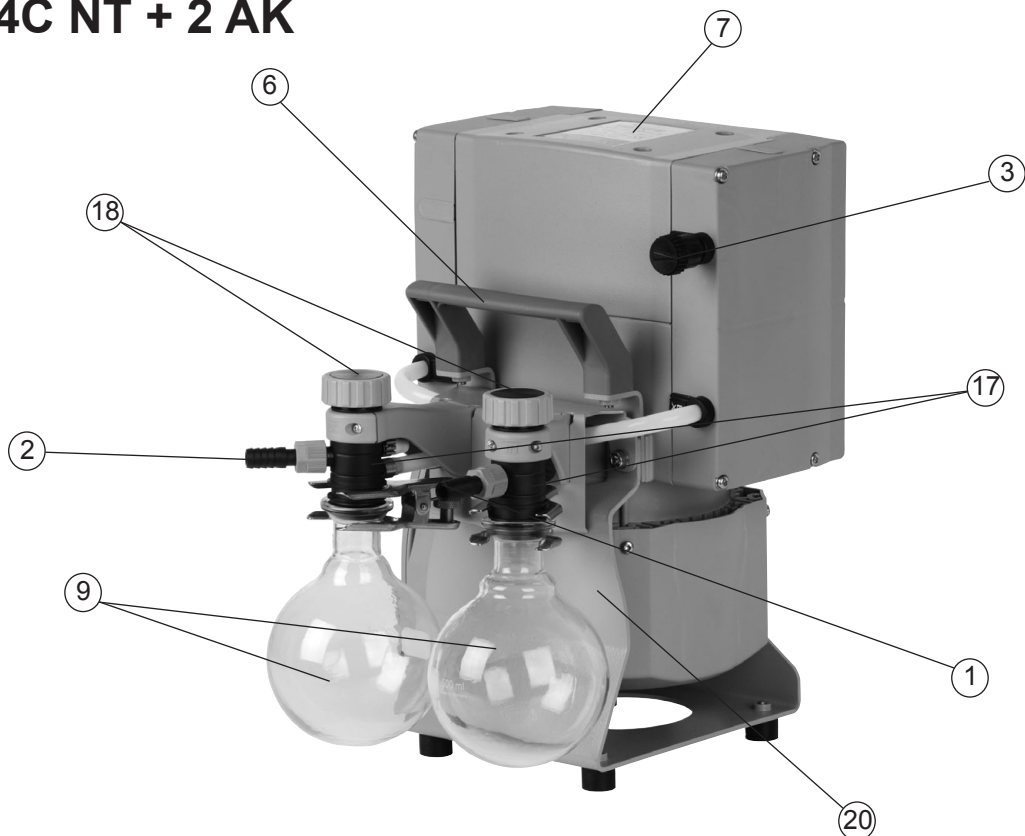

**Power connection and ON/OFF switch: see MD 4C NT**

### MD 4C NT + AK + EK

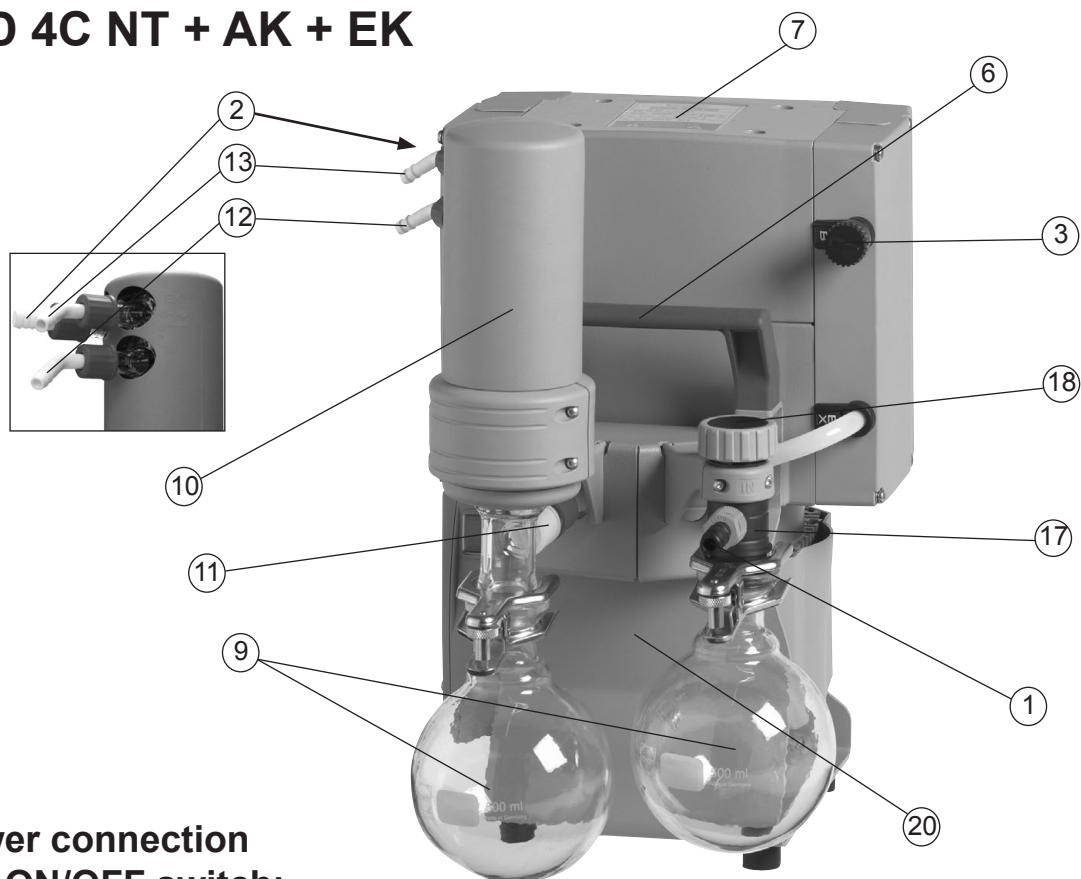

**Power connection  
and ON/OFF switch:  
see MD 4C NT**

### MD 4C NT + AK SYNCHRO + EK

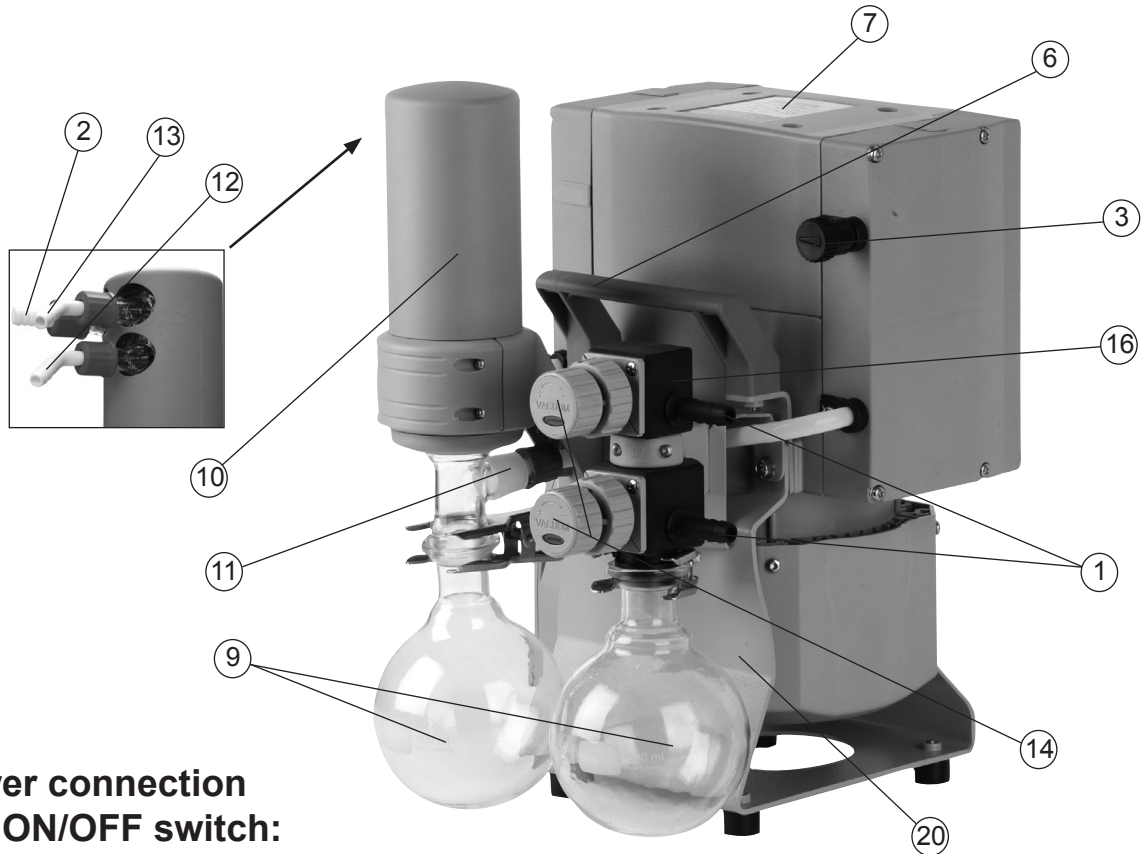

**Power connection  
and ON/OFF switch:  
see MD 4C NT**

### PC 201 NT

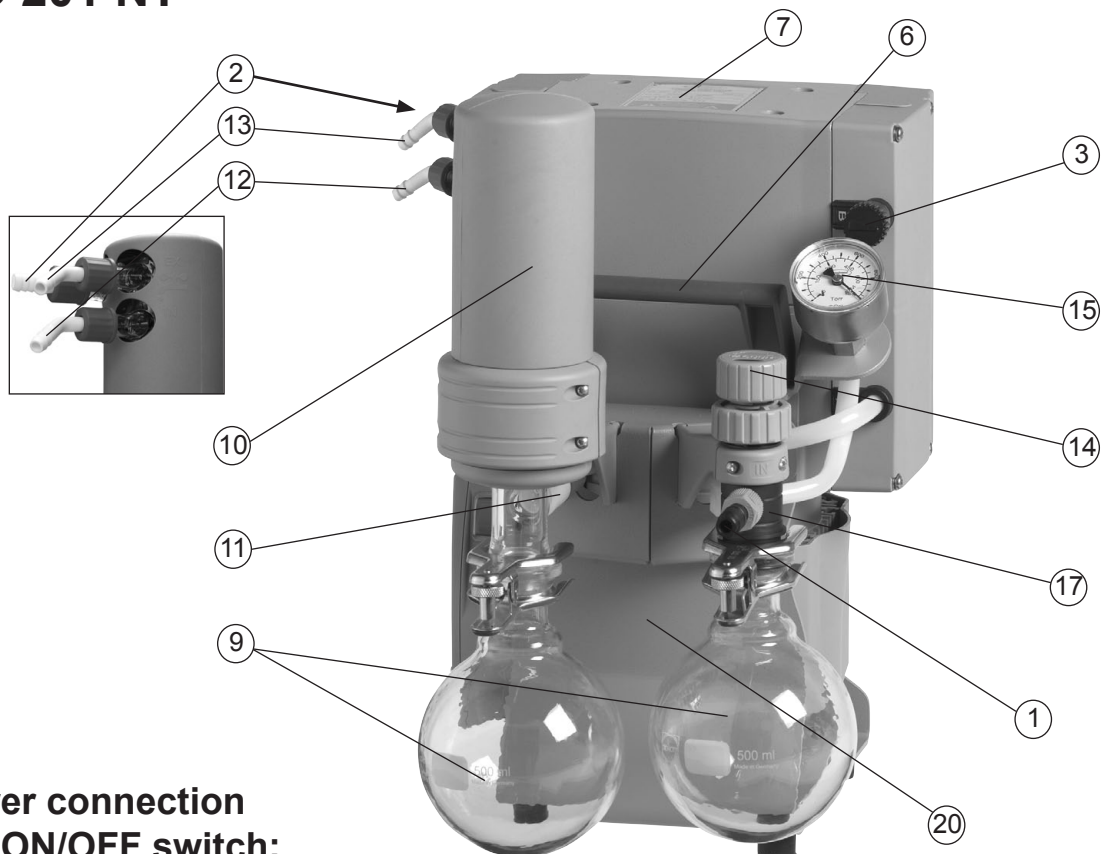

**Power connection  
and ON/OFF switch:  
see MD 4C NT**

# Use and operation

## *Installing a pump in a vacuum system*

### **DANGER**

- ➔ If dangerous or polluting fluids could be released at the outlet, install an appropriate system to catch and dispose of those fluids.

### **WARNING**

- ☞ Connect a gas-tight exhaust line at the pump outlet if necessary. Always vent exhaust gases appropriately (e.g., into a fume hood).
- ☞ Never block the gas outlet. The exhaust line must always be free of obstructions (no back pressure) to ensure an unimpeded discharge of gas. The cross-section of the outlet tubing must be at least the size of the pump's exhaust connection.
- ☞ Particles and dust must not be aspirated. If necessary, you must install appropriate filters. You must ensure their suitability concerning gas flow, chemical resistance and resistance to clogging prior to use.
- ☞ Make sure ventilation is adequate, especially if the pump is installed in an enclosure, or if the ambient temperature is elevated. Provide external ventilation, if necessary.

### **CAUTION**

- Reduce the transmission of vibration. Prevent mechanical load due to rigid pipelines. Insert elastic hoses or flexible elements as couplings between the pump and rigid pipes. **Note:** Flexible elements will compress or flatten when evacuated if not designed for use under vacuum.
- Hose connections at the pump inlet must always be gas tight.
- A power failure may cause accidental ventilation of the pump, especially if the gas ballast valve is open. If this constitutes a potential source of danger, take appropriate safety measures.

- Check the power source and the pump's rating plate to be sure that the power source and the equipment match in voltage, phase, and frequency.
- **Pump with dual-voltage motor:** Check that the voltage selection switch at the terminal box is positioned correctly. Check every time before starting the pump.  
**Note:** If the pump is switched on with wrong voltage selection, the motor may be damaged!  
**Change the selection at the voltage selection switch only, if the pump is unplugged from the power source.**

### Voltage selection switch:

1. **Disconnect the electrical power cord.**

2. Use a screw driver to adjust the **voltage selection switch** at the terminal box of the pump to the supply voltage:

"115" corresponds to 90-126 V and

"230" corresponds to 180-253 V.



voltage selection switch



## NOTICE

Keep a distance of minimum 8 in (20 cm) between fan and adjacent equipment or casework.

Use connecting hoses with large diameter and keep them as short as possible to avoid flow losses. Locate the pump as closely as possible to the application.

Always install outlet tubing descending from the pump to avoid backflow of condensate towards the pump.

Use a suitable valve to isolate the pump from the vacuum application. This is to allow the pump to warm up before pumping condensable vapors and to clean the pump after use before it is switched off.

When assembling, ensure **vacuum-tightness**. After assembly, check the whole system for leaks.

Secure hose connections at the pump appropriately, e.g., with hose clamps, to protect against accidental detachment.

To reduce pump noise emanating from the pump exhaust port, connect an exhaust hose or use a silencer (see "Accessories", pg. 48).

### ***Separator (inlet) and exhaust waste vapor condenser (outlet)***

#### **Assembling the hose nozzle with union nut:**

- ➔ Take the hose nozzle with attached compression ferrule and union nut out of the catchpot and put onto inlet connection (version 2 AK: onto inlet and outlet connections).
- ➔ Tighten the union nut by hand until you can feel the stop. Then tighten an additional 1/4 rotation with an open-ended wrench (size 17mm) for final installation.

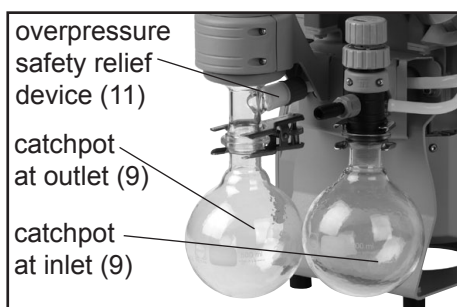

#### **Catchpots:**

The catchpot at the inlet protects against droplets and particles from entering the pump.

- ☞ Enhances lifetimes of diaphragms and valves.
- ☞ Improves vacuum performance in applications with condensable vapors.

Both catchpots are coated with a protective layer to protect against shattering in case of breakage or implosion.

- ➔ Assemble the catchpots at the inlet and at the outlet using joint clips.

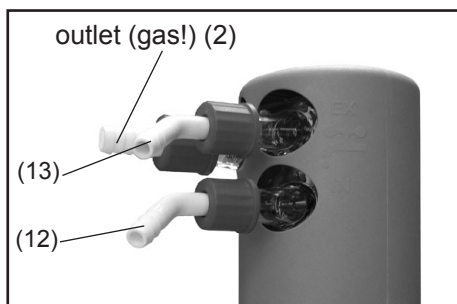

#### **Exhaust waste vapor condenser:**

- ➔ Assemble the hose nozzles for coolant inlet (12) and coolant outlet (13) tubing at the exhaust waste vapor condenser.

The **exhaust waste vapor condenser** enables an efficient condensation of the pumped vapors at the outlet.

- ☞ No backflow of condensates.
- ☞ Controlled recovery of condensates.
- ☞ Close to 100% solvent recovery.
- ☞ The isolation cover protects against glass

splinters in case of breakage, acts as thermal isolation to avoid condensation of humidity and is intended to absorb shocks.

- ➔ Attach the tubing of the coolant circuit to the respective hose nozzles (hose nozzles for tubing I.D. 1/4"-5/16" (6-8 mm), see image) at the waste vapor condenser.

### NOTICE

Check all hose connections prior to starting operation of the cooling system.

Secure coolant hoses at the hose nozzles (e.g., with hose clamps) to prevent their accidentally slipping off.

### ! DANGER

- ➔ Prevent the discharge of dangerous gases and vapors to the surrounding atmosphere. If appropriate, connect the exhaust line to a suitable treatment system.

### ! WARNING

- ☞ Never block the gas outlet ((2) hose nozzle for tubing I.D. 3/8" (10 mm)). The exhaust hose has always to be unobstructed and without back pressure to enable an unhindered discharge of gases and protect the pump valves from damage.

### ! CAUTION

- **Note:** Install the hoses of the cooling system in a way to avoid the flow / dripping of condensed water onto the pumping unit (especially cables and electronic parts, see also IP degree of protection, "Technical data", pg. 24).
- Ensure that the **coolant outlet tubing** is always unobstructed and that it cannot get blocked.
- Maximum permissible coolant pressure at the exhaust waste vapor condenser: 87 psi (6 bar) absolute. Outlet flow must always be unhindered.
- Comply with the maximum permissible coolant pressures of additional components in the coolant circuit (e.g., coolant valve).
- Avoid overpressure in the coolant circuit (e.g., caused by blocked or squeezed coolant hoses).
- Only install the optional coolant valve in the supply line of the exhaust waste vapor condenser.

## *During operation*

### **DANGER**

- ➔ Vent and dispose of **potentially dangerous gases or vapors** at the outlet of the pump appropriately.

### **WARNING**

- ☞ Due to the high compression ratio, the pump might generate overpressure at the outlet. Check pressure compatibility with system components (e.g., exhaust tubing or exhaust valve) at the outlet. Ensure that the pump outlet is neither blocked nor restricted.

- ☞ **Maximum ambient temperature:** 104 °F (40 °C)  
Check the maximum temperatures, if installing the pump in a cabinet or a housing. Make sure ventilation is adequate, especially if the ambient temperature is elevated.

### **CAUTION**

- If the pump is installed at an altitude of more than 3300 ft (1000 m) above mean sea level, check compatibility with applicable safety requirements, especially IEC 60034. There is a risk of the motor overheating due to insufficient cooling.
- Check compatibility with the **maximally permitted pressure** at outlet and the **maximum pressure difference** between inlet and outlet ports.

### **NOTICE**

Do not start the pump if the **pressure difference between inlet and outlet ports exceeds max. 16.0 psi (1.1 bar)**. Attempts to start the pump at higher pressure difference may cause stalling and damage of the motor.

If pumping condensable vapors (water vapor, solvents, etc.), let the pump run with **gas ballast** to help purge any condensation in the pump.

Prevent internal condensation, transfer of liquids or dust. The diaphragms and valves will be damaged, if liquids are pumped in significant amounts.  
Check the pump regularly for external soiling and depos-

its. Clean the pump if necessary to avoid an increase of the pump's operating temperature.

Operation with silencer (optional) at the outlet: Operating the pump at a high inlet pressure or pumping dusty gases for a long time may cause clogging of the silencer. Check the silencer regularly and replace if necessary.

In case of overload, the motor is shut down by a **self-hold thermal circuit breaker** in the winding.

**Note:** Only a manual reset is possible. Switch off the pump and disconnect the electrical power cord. Identify and eliminate the cause of failure. Wait approximately five minutes before restarting the pump.

### **CAUTION**

- **Note:** In case of **supply voltage below 100V**, the lock of the breaker may not latch and the pump might restart on its own after sufficient cooling. Take appropriate precautions, if an automatic restart of the pump may lead to a dangerous situation.

### **NOTICE**

A warm up period (approximately 15 min.) is required to ensure that the rated ultimate vacuum and pumping speed are attained. Avoid overheating (e.g., due to hot process gases).

#### **Pumps with flow control diaphragm valve:**

Use the flow control diaphragm valve (14) at the pump inlet to control the pumping speed. Open flow control diaphragm to pump down.

- ➔ Opening the flow control diaphragm: Turn counterclockwise. Do not attempt to open the valve further than when resistance is first encountered.
- ➔ Closing: Turn clockwise. Close flow control diaphragm valve slightly hand-tight. Further tightening will not increase sealing of the valve, and may lead to damage.

### **NOTICE**

**Note:** Over-tightening or -loosening may damage the diaphragm or the valve seat, and the valve may not close properly thereafter.

Replace diaphragm in case of leaks.

## ***Important notes regarding the use of gas ballast***

Gas ballast is a continuous purge to keep the pump's interior as clean as possible and to reduce the possibility of condensation inside the pump.

### **! DANGER**

➔ Air and pumped media might react inside the pump or at the outlet of the pump and form hazardous or explosive mixtures, when you use air rather than inert gas for the gas ballast. This constitutes a risk of significant damage to equipment and/or facilities, a risk of personal injury or even loss of life.

### **! WARNING**

☞ Make sure that air/gas intake through the gas ballast valve can never lead to hazardous, explosive or otherwise dangerous mixtures. If in doubt, use inert gas.

### **NOTICE**

To reduce condensation in the pump, do not pump vapor before the pump has reached its operating temperature. Open the gas ballast valve when pumping condensable vapors. Turn gas ballast cap to open valve.

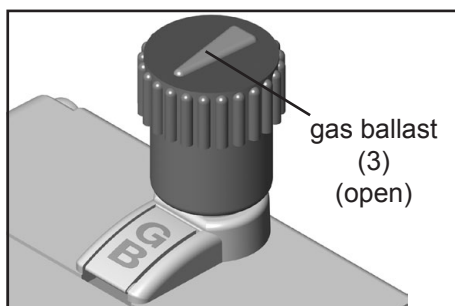

For **condensable vapors** (water vapor, solvents, etc.):

- The gas ballast valve is open if the arrow on the gas ballast cap is pointing towards the labelling "GB".
- With gas ballast valve open, the ultimate vacuum will be reduced.
- Use inert gas for gas ballast to avoid the formation of explosive mixtures. A special adapter fitting is needed to connect an inert gas supply line (see "Accessories", pg. 48). This adapter replaces the standard gas ballast cap and allows for an inert gas line to be connected via a KF DN 16 small flange at a maximum supply pressure of 17.5 psi (1.2 bar) absolute.
- Close the gas ballast valve by turning the cap 180°.

In case of low boiling solvents (when the formation of condensate is unlikely), the use of gas ballast might be unnecessary. Operating the pump without gas ballast increases the solvent recovery rate at the exhaust waste vapor condenser.

### ***Important notes concerning the operation of the exhaust waste vapor condenser***

#### **! DANGER**

➔ Connect the exhaust to a suitable treatment system to prevent the discharge of dangerous gases and vapors to the surrounding atmosphere.

#### **! WARNING**

☞ Never block the gas outlet ((2) hose nozzle for tubing I.D. 3/8" (10 mm)). The exhaust hose must always be unobstructed and without back-pressure to enable an unhindered discharge of gases.

☞ Check the overpressure safety relief device (11) at the exhaust waste vapor condenser (10) regularly; replace if necessary. Check especially for deterioration, coalescence and cracks.

#### **! CAUTION**

- Ensure that the **coolant outlet hose** is always free and that it cannot get blocked.
- Maximum permissible coolant pressure at the exhaust waste vapor condenser: 87 psi (6 bar) absolute
- Comply with the maximum permissible coolant pressures of additional components in the coolant circuit (e.g., coolant valve).
- We strongly recommend installing an optional coolant valve (see "Accessories", pg. 48) **in the supply line** of the exhaust vapor condenser to save water and reduce the risk of water spill.
- Avoid overpressure in the coolant circuit (e.g., caused by blocked or kinked coolant hoses).

#### **NOTICE**

In case of **condensation**: Check the liquid level in both catchpots (9) during operation. Check the liquid level in both catchpots regularly. Do not allow the catchpots to

overflow. Drain catchpots in time to avoid overflow. Install a level sensor (see "Accessories", pg. 48) for monitoring, if necessary (VACUUBRAND controller CVC 3000 or VNC 2 is required).

The maximum liquid level is at approximately 80% of the total filling level to avoid problems when removing the catchpots.

Permissible range of coolant temperature at the exhaust waste vapor condenser:

5 °F to 68 °F (-15°C to +20°C)

Check hose connections prior to starting operation of the cooling system.

Check coolant hoses regularly during operation.

### Removing the catchpots:

Catchpot at outlet:

Remove joint clip. Remove catchpot and drain condensate.

Catchpot at inlet:

Admit air or inert gas (via the pump inlet) to restore atmospheric pressure in the catchpot before attempting removal.. Remove joint clip. Remove catchpot and drain condensate.

### NOTICE

Reattach drained catchpots.

### WARNING

☞ **Important:** Comply with regulations when disposing of solvents/condensates. Recycle if possible; purify if contaminated.

## ***Shutdown & storage***

The pump can be switched off under vacuum.

### **NOTICE**

#### **Short-term:**

Has the pump been exposed to condensate?

Allow the pump to continue to run at atmospheric pressure for a few minutes.

Has the pump been exposed to media which may damage the pump materials or form **deposits**?

Check and clean pump heads if necessary.

#### **Long-term:**

Take measures as described above regarding short-term shutdown.

Separate the pump from the application.

Close inlet and outlet ports (e.g., with transport caps).

Close the gas ballast valve.

Drain catchpots.

Store the pump under dry conditions.

# Accessories



**Digital vacuum gauge DVR 2** .....682902

**Level sensor** for catchpots .....699908

**Vacuum hose (caoutchouc)** I.D. 3/8" (10 mm ID) .....686002

**Silencer** for hose nozzle 3/8" (DN 10 mm) .....636588

**Attention:** Dust-laden gases, deposits and condensed solvent vapor can restrict air flow out the silencer. The resultant back pressure can lead to damage of pump bearings, diaphragms, and valves. Under those conditions, a silencer must not be used.

**Check valve (flapper valve)** .....639683

(Simultaneous operation of two systems at different pressure levels,  
stainless steel/FFKM, leak rate <math>1.6 \cdot 10^{-3}</math> Torr\*cfm  
for pressure differences > 375 Torr (500 mbar))

## Upgrade possibilities for NT vacuum systems:

**Upgrade kit SYNCHRO** ..... 699920

to two inlets (valve block; replaces distribution head)

**Adapter G 1/4 thread to PTFE tubing\***, .....677060

for inlet at valve block (SYNCHRO)

**Small flange KF DN 16** .....662593

for assembly at inlet of valve block (SYNCHRO)

**Seal ring** for small flange KF DN 16 (662593) .....3120565

**Hose nozzle for tubing I.D. 1/4" / 3/8" (DN 6/10 mm)**,.....642470

for inlet at valve block (SYNCHRO)

**Modification kit for small flange KF DN 16**.....699939

at inlet of distribution head

**Hose nozzle for tubing I.D. 1/4" / 3/8" (DN 6/10 mm)**,.....636635

for inlet at distribution head

**Elbow piece (90°) for PTFE tubing\*** .....637873

for assembly at inlet of distribution head

**Adapter for gas ballast connection** .....636193

Via small flange KF DN 16

**Blind flange (C1)** .....677136

for assembly at valve block or distribution head

<b>Flow control diaphragm valve (C2)</b> .....	<b>677137</b>
for assembly at valve block or distribution head	
<b>Solenoid operated valve (C3-B)</b> .....	<b>636668</b>
for assembly at valve block or distribution head	
<b>Manometer module (C5)</b> .....	<b>677100</b>
for assembly at valve block or distribution head	
<b>Controller CVC 3000</b> .....	<b>683160</b>
<b>In-line valve VV-B 6C</b> .....	<b>674291</b>
<b>VACUU•LAN® Mini-Network</b> with three VCL 01 modules .....	<b>2614455</b>
<b>Vacuum adjustment device</b> with manometer .....	<b>696840</b>

## Ways to connect NT chemistry diaphragm pumps:

<b>Small flange KF DN 16,</b> .....	<b>677058</b>
with hose - for installation at hose nozzle	
<b>Small flange KF DN 16,</b> .....	<b>699918</b>
for assembly directly at the valve head (at inlet of ME 4C NT / ME 8C NT / MD 4C NT; at outlet of ME 4C NT / MZ 2C NT)	
<b>Small flange KF DN 16,</b> .....	<b>699919</b>
for assembly directly at the valve head (at outlet of ME 8C NT / MD 4C NT)	
<b>Adapter hose nozzle DN 10 to hose nozzle 1/2"</b> .....	<b>636002</b>
<b>Adapter to PTFE tubing*</b> , .....	<b>636274</b>
for assembly directly at the valve head (at inlet of ME 4C NT / ME 8C NT / MD 4C NT; at outlet of ME 4C NT / MZ 2C NT)	
<b>Adapter to PTFE tubing*</b> , .....	<b>636275</b>
for assembly directly at the valve head (at inlet of MZ 2C NT; at outlet of ME 8C NT / MD 4C NT)	
<b>Elbow connecting piece (90°) for PTFE tubing*</b> .....	<b>638434</b>
<b>T-piece for PTFE tubing*</b> .....	<b>638435</b>
<b>PTFE tubing*</b> (sold by meter) .....	<b>638644</b>

\* PTFE tubing DN 10/8 mm

VACUU•LAN® networks are engineered to perform to specification when installed with PTFE tubing, DN 10/8 mm. All VACUU•LAN® modules, pumps and connectors are designed for compatibility with this tubing.

## Spare parts:

<b>Catchpot 0.52 qt (500 ml), coated</b> .....	<b>638497</b>
--	---------------

For additional accessories such as vacuum valves, small-flange components, vacuum gauges or vacuum controllers refer to [www.vacuubrand.com](http://www.vacuubrand.com)

# Troubleshooting

Fault	Possible cause	Remedy
<input type="checkbox"/> Pump does not start or stops immediately.	<ul style="list-style-type: none"> <li>➔ Electrical power cord not plugged in, electrical supply failure?</li> <li>➔ Device fuse blown?</li> <li>➔ Overpressure in outlet line?</li> <li>➔ Motor overloaded?</li> </ul>	<ul style="list-style-type: none"> <li>✓ Plug in power cord. Check fuse.</li> <li>✓ Identify cause of failure. Replace device fuse.</li> <li>✓ Remove blockage in line, open valve.</li> <li>✓ Allow motor to cool down, identify and eliminate cause of failure. Manual reset is necessary. Switch off pump or unplug.</li> </ul>
<input type="checkbox"/> Pump does not achieve its ultimate vacuum or usual pumping speed.	<ul style="list-style-type: none"> <li>➔ Centring ring at small flange connection not correctly positioned, or leak in the pipeline or vacuum system?</li> <li>➔ Long, narrow vacuum line?</li> <li>➔ Pump has been exposed to condensate?</li> <li>➔ Deposits have been formed inside the pump?</li> <li>➔ Diaphragms or valves damaged?</li> <li>➔ Outgassing substances or vapor generated in the process?</li> </ul>	<ul style="list-style-type: none"> <li>✓ Check pump directly - connect vacuum gauge directly at pump inlet - then check connection, pipeline and vacuum system if necessary.</li> <li>✓ Use lines with larger diameter, length as short as possible.</li> <li>✓ Allow pump to run for some minutes with atmospheric pressure at the inlet to purge.</li> <li>✓ Clean and inspect the pump heads.</li> <li>✓ Replace diaphragms and/or valves.</li> <li>✓ Check process parameters.</li> </ul>

Fault	Possible cause	Remedy
<input type="checkbox"/> Pump too noisy.	<ul style="list-style-type: none"> <li>➔ Atmospheric or high pressure at the pump inlet?</li> <li>➔ Diaphragm crack or diaphragm clamping disc loose?</li> <li>➔ Other than above mentioned causes?</li> </ul>	<ul style="list-style-type: none"> <li>✓ Connect hose or silencer to pump outlet. Be careful not to cause outlet over-pressure, especially with condensable vapors.</li> <li>✓ Perform maintenance.</li> <li>✓ Contact local distributor.</li> </ul>
<input type="checkbox"/> Pump seized.		<ul style="list-style-type: none"> <li>✓ Contact local distributor.</li> </ul>

- ➔ A service manual with exploded view drawings, spare parts list and directions for repair is available on request.
- 👉 The service manual is intended for trained service people only.

# Replacing diaphragms and valves

☞ **Please read section "Replacing diaphragms and valves" completely before starting maintenance.**

The pictures may show other versions of pumps. This does not change the method of replacing diaphragms and valves.

## **! DANGER**

➔ **Never operate the pump if covers or other parts of the pump are disassembled.**



➔ Before starting maintenance, **disconnect the electrical power cord. Wait two minutes** after isolating the equipment from AC power to allow the capacitors to discharge.

➔ Ensure that the pump cannot be operated accidentally.

➔ **Note:** The pump might be contaminated with the process chemicals that have been pumped during operation. Ensure that the pump is decontaminated before maintenance.

➔ Avoid the release of pollutants.

## **! WARNING**

☞ **Never operate a defective or damaged pump.**

☞ Take adequate precautions to protect people from the effects of dangerous substances that may have contaminated the pump and may be released upon disassembly. Ensure that the maintenance technician is familiar with the safety procedures which relate to the products processed by the pumping system.

Use appropriate protective clothing, safety goggles and protective gloves.

☞ Check every motor capacitor regularly by measuring its capacity and estimating its service life. Replace old capacitors early enough to prevent a failure. The capacitors must be replaced by a trained electrician.

☞ Allow sufficient cooling of the pump before starting maintenance. Drain condensate, if applicable.

☞ **Vent the pump and isolate it from the vacuum system before you start maintenance.**

**NOTICE**

**Ensure that maintenance is done only by suitably trained and supervised technicians.**

The valves and diaphragms as well as the motor capacitors are wear parts. If the rated ultimate vacuum is no longer achieved or in case of increased noise level, the pump interior, the diaphragms and the valves must be cleaned and the diaphragms and valves must be checked for cracks or other damage.

All bearings are encapsulated and are filled with long-life lubricant. Under normal operating conditions, the drive system is maintenance free.

In demanding circumstances, it may be efficient to check and clean the pump heads on a regular basis. In normal use, the lifetime of the diaphragms and valves is more than 10,000 operating hours.

- Prevent internal condensation, transfer of liquids or dust. The diaphragms and valves will be damaged if liquid is pumped in significant amount.
- Carry out maintenance frequently if the pump is exposed to corrosive media or in case of deposits.
- Regular maintenance will improve the lifetime of the pump and also protect both users and the environment.

<b>Service kit for ME 2C NT</b> .....	<b>696878</b>
<b>Service kit for ME 4C NT</b> .....	<b>696864</b>
<b>Service kit for MZ 2C NT / PC 201 NT</b> .....	<b>696869</b>
<b>Service kit for MD 4C NT / PC 201 NT</b> .....	<b>696870</b>
<b>Service kit for ME 8C NT</b> .....	<b>696867</b>
<b>Diaphragm key (width 66 mm)</b> .....	<b>636554</b>

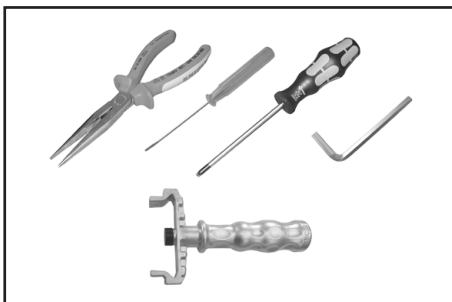
**Tools required (metric):**

- Torx driver T20
- 5 mm wide Allen key
- 2.5 mm wide slotted screwdriver
- Flat pliers
- Diaphragm key width 66 mm

## Cleaning and inspecting the pump heads

The replacement of the diaphragm and the replacement of the valves can be carried out separately.

- ☞ To replace the valves, remove the head covers of one side of the pump along with the assembled valve heads and fittings.
- ☞ To maintain the diaphragms, the valve heads and the fittings need not be disassembled. The head covers can be removed along with the assembled valve heads and fittings.
  
- ☞ Service only one side of the pump at a time to avoid the mixing of parts.



### Pump on pump support:

- ➡ Remove catchpots (9) at inlet and outlet (see "Use and operation", page 38).

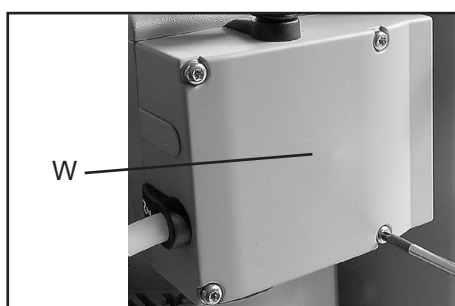

- ➡ Remove the 4 screws affixing the head cover cowling (W) with a Torx driver T20. Pay attention to the washers under the screws and remove.
- ➡ Pull off head cover cowling (W) carefully. Do not tilt.

# Fittings and tubing of the different pump models:

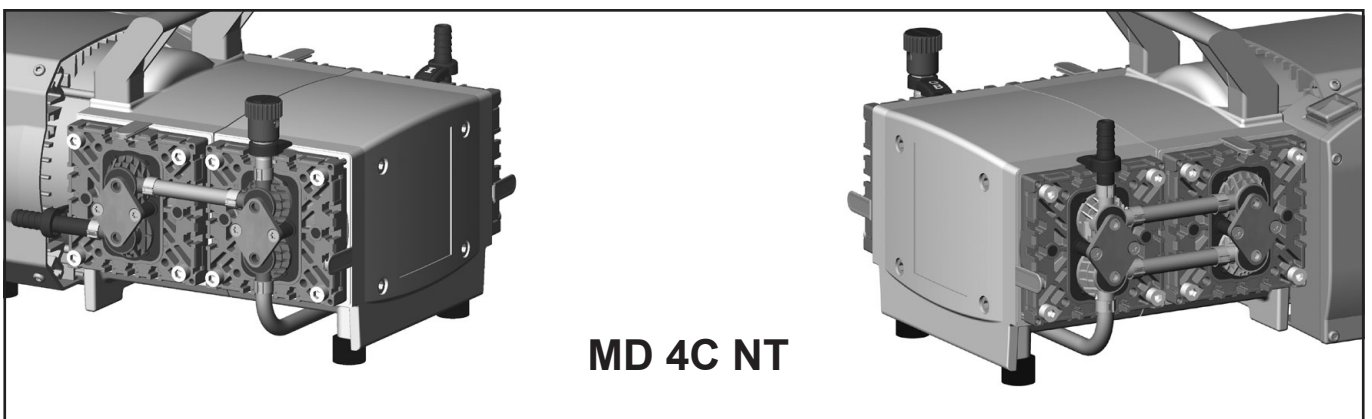
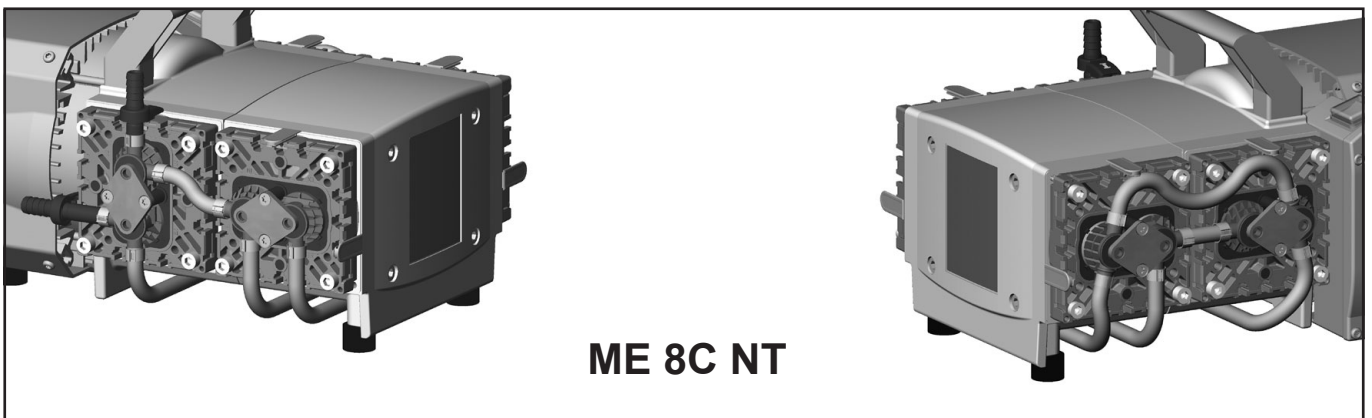
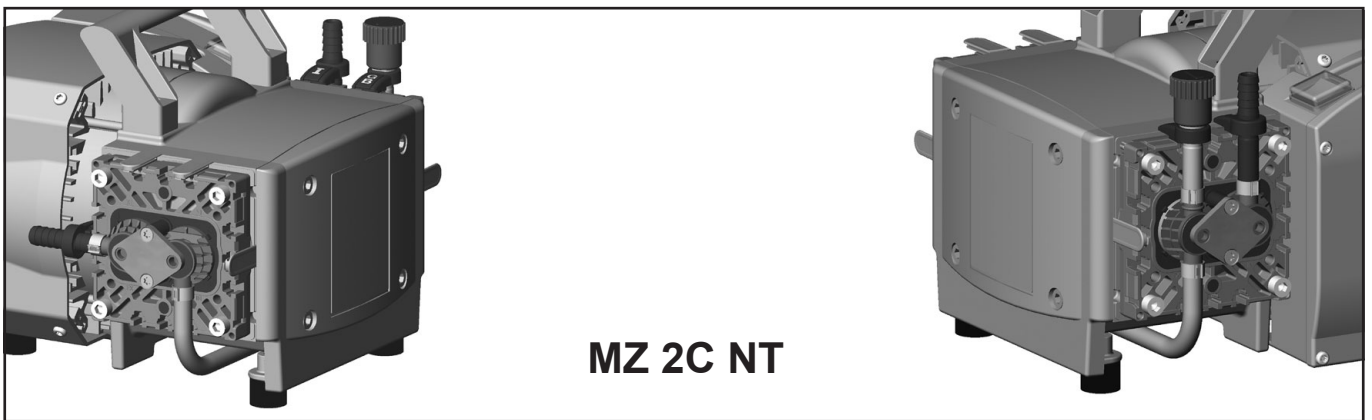
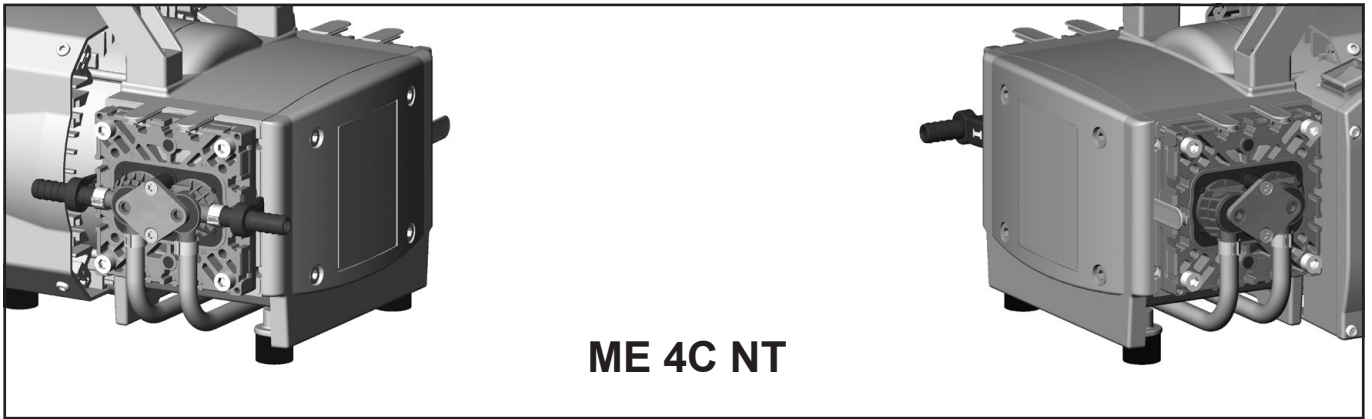

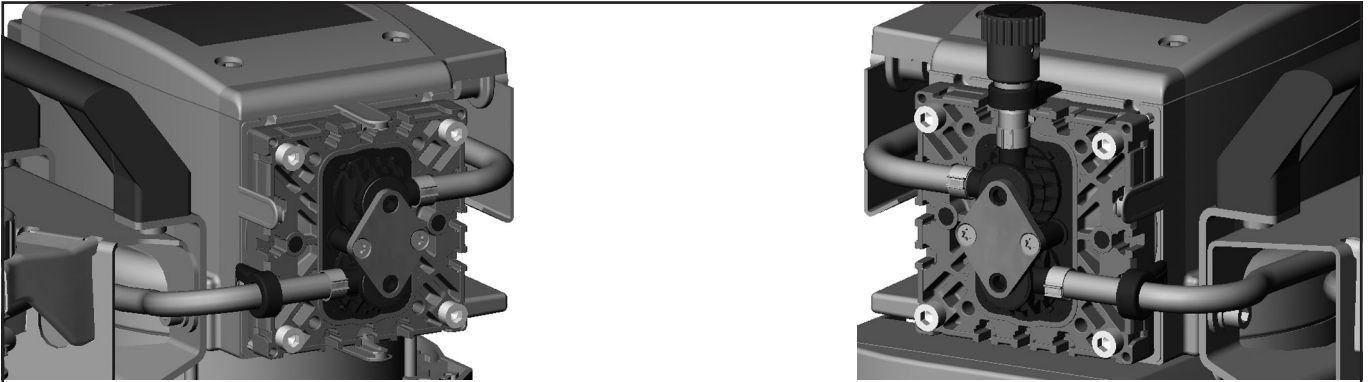

**MZ 2C NT 2AK  
MZ 2C NT AK + EK  
MZ 2C NT AK SYNCHRO + EK  
PC 101 NT**



**MD 4C NT 2AK  
MD 4C NT AK + EK  
MD 4C NT AK SYNCHRO + EK  
PC 201 NT**

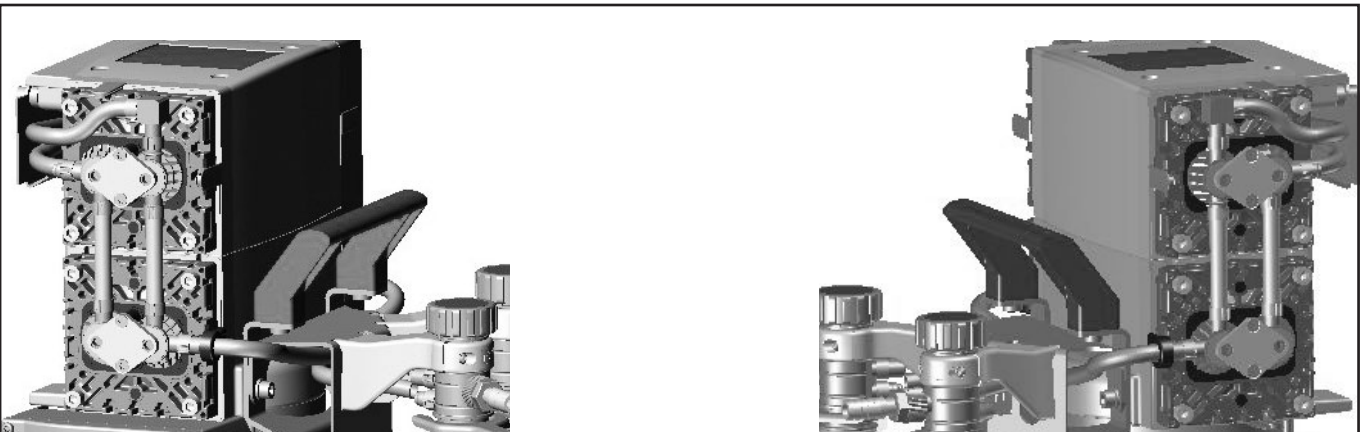

**ME 8C NT + 2 AK**

## View of the disassembled pump head parts

(fig.: MD 4C NT)

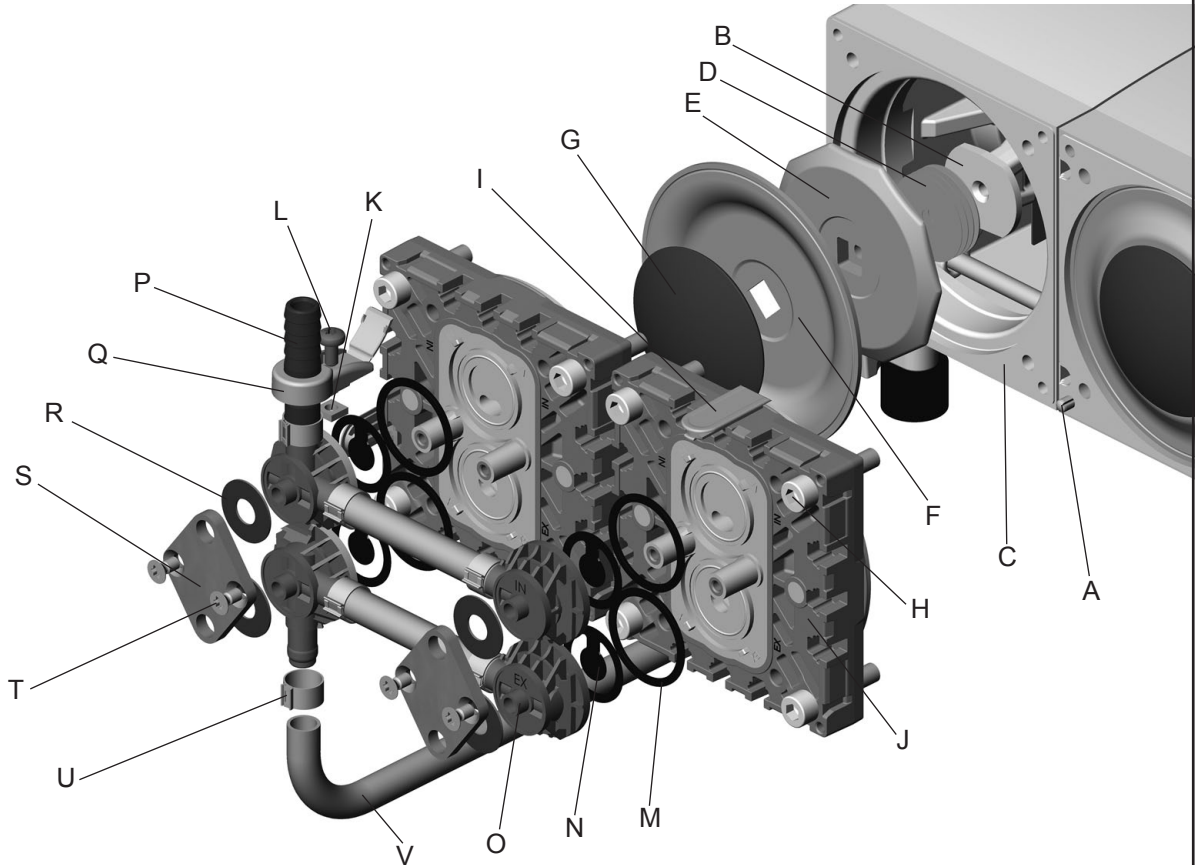

- |  |   |
|--|---|
| A: Head alignment pin / mark                         | L: Fillister head screw                     |
| B: Connecting rod                                    | M: O-ring                                   |
| C: Housing   | N: Valve                                    |
| D: Washer  | O: Valve head                               |
| E: Diaphragm support disc                            | P: Hose nozzle                              |
| F: Diaphragm   | Q: Connection fastener<br>with hinged cover |
| G: Diaphragm clamping disc<br>with square head screw | R: Disc spring                              |
| H: Allen screw                                       | S: Clamping bracket                         |
| I: Cap   | T: Countersunk screw                        |
| J: Head cover  | U: Hose clip                                |
| K: Square nut  | V: Connection tube                          |

This labeling is used throughout the following pages.

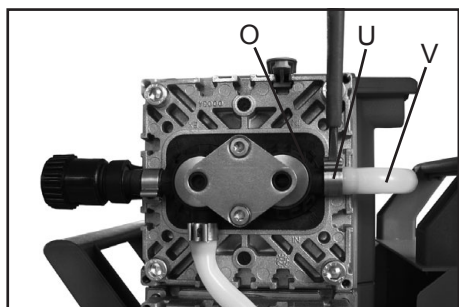

Detach the coupling of the connection tube (V) to the other side of the pump at the valve head (O).

### **Pump at pump support:**

Detach the coupling of the connection tube (V) to the other side of the pump as well as the hose connection to the inlet/outlet of the vacuum system at the valve head (O).

- Open the hose clip (U) with a slotted screwdriver.
- Pull the tubing off the hose connector.

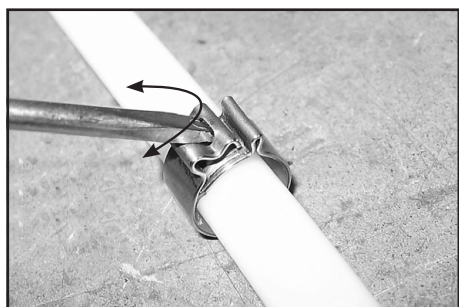

Opening the hose clip:

- Apply slotted screwdriver as shown and turn.

## **Replacing the diaphragm**

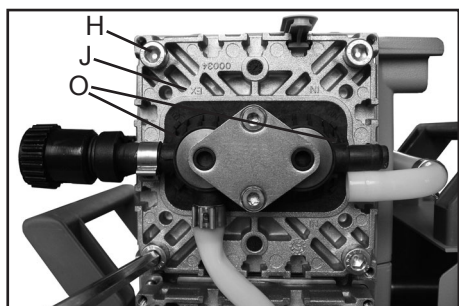

- Disassemble head covers (J) to check the diaphragm (F).
- Unscrew four (pump with one/two heads) or eight (pump with four heads) Allen screws (H) with a 5mm wide Allen key. Remove both head covers (J) (pumps with one/two heads: only one head cover) together with valve heads (O) and connections.
- ☞ It is not necessary to disassemble the valve heads (O), the connection fasteners (Q), or the hose connection between the adjacent head covers (pumps with four heads).

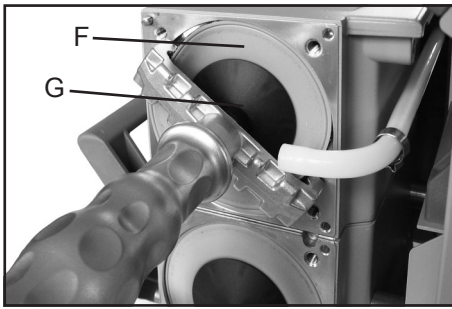

- ☞ Check diaphragm (F) for damage and replace if necessary.
- ➡ Lift diaphragm carefully sidewise.
- ☞ Never use a pointed or sharp-edged tool to lift the diaphragm.
- ➡ Use the diaphragm key to grip the diaphragm support disc (E) below the diaphragm.
- ➡ Unscrew diaphragm support disc (E) with diaphragm (F) and diaphragm clamping disc (G).
- ➡ Check for washers (D) between the diaphragm support disc (E) and the connecting rod (B). Do not mix the washers from the different pump heads, since these are set at the factory to ensure proper pump performance. Make sure that the original number is reassembled at the individual pump head.
- ☞ Too few washers: The pump will not attain vacuum specification. Too many washers: Diaphragm clamping disc will hit head cover, causing noisy operation and possibly causing the pump to seize up.
- ☞ If the old diaphragm is difficult to separate from the diaphragm support disc, immerse assembly in naphtha or petroleum ether. Do not inhale vapors!

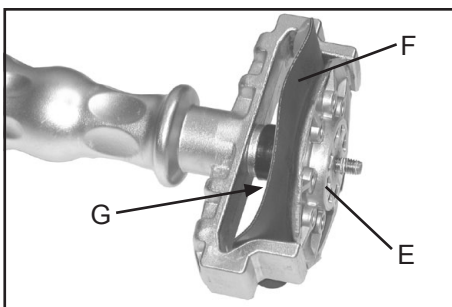

- ➡ Position new diaphragm (F) between diaphragm clamping disc with square head screw (G) and diaphragm support disc (E).
- ☞ Note: Position diaphragm with pale side towards diaphragm clamping disc (facing pump chamber).
- ☞ Make sure that the square head screw of the diaphragm clamping disc is correctly seated in the guide hole of the diaphragm support disc.
- ➡ Lift the diaphragm at the side. Place the diaphragm carefully together with diaphragm clamping disc and diaphragm support disc in the diaphragm key.
- ☞ Avoid damage of the diaphragm: Do not excessively bend or crease the diaphragm.

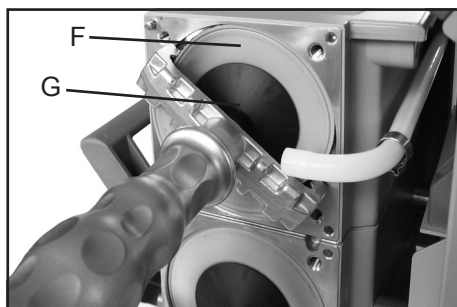

- ☞ Assemble the original number of washers (D) between diaphragm support disc (E) and connecting rod (B).
- ➡ Screw diaphragm clamping disc (G), diaphragm (F), diaphragm support disc (E), and washers (D) to connecting rod (B).

- ➡ Optimum torque for the diaphragm support disc: 4.4 ft·lb<sub>f</sub> (6 Nm), it is recommended to use a torque wrench. Attach torque wrench to diaphragm key (hexagonal bolt 6 mm wide).

Note: Never use the diaphragm key with any additional tools like tongs or Allen keys without appropriate torque limitation.

## Replacing the valves

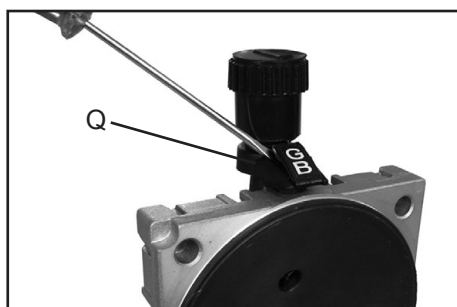

- ➡ Open the hinged cover of the connection fastener (Q) with a slotted screwdriver.



- Loosen connection fastener slightly.
- ➡ Turn the fillister head screw (L) with a Torx driver T20 at most one turn.
- ☞ Do not detach the fillister head screw from the square nut (K).

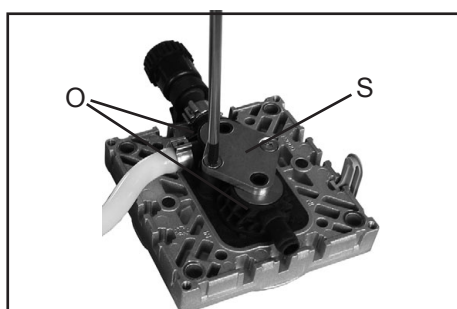

- Loosen the clamping brackets (S) on the valve heads (O).
- ➡ Unscrew at each clamping bracket the two countersunk screws with a Torx driver T20. Remove the clamping brackets.

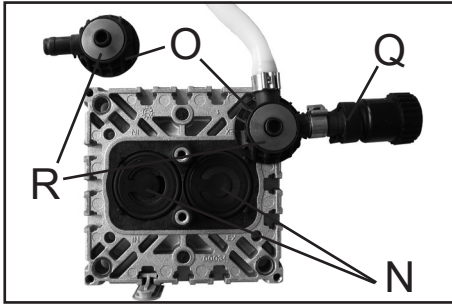

- Remove valve heads (O) along with the disc springs (R), connection tube if applicable, hose nozzles (P) and connection fasteners (Q) or move the valve heads carefully aside. Note position and orientation of the valve heads.
- ☞ Note position and alignment of valves (N).

- Check valves (N) and O-rings (M) for damage and soiling.
- Replace valves or O-rings if necessary.
- Use petroleum ether or other industrial solvent to remove deposits. Do not inhale vapors.

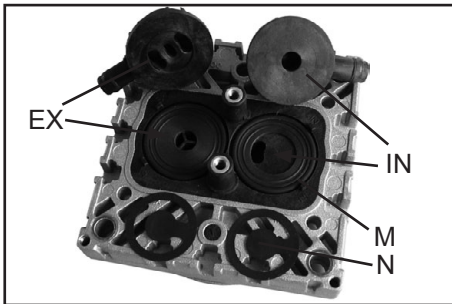

- Insert O-rings (M) and valves (N). See figure for the correct position of the valves:
- ☞ Inlet side (IN):  
Marked "IN" next to the valve seat. The valve tongue points at the kidney-shaped orifice in the valve seat.
- ☞ Outlet side (EX):  
Marked with "EX" next to the valve seat. The valve is oriented the same direction as the valve at the inlet side.

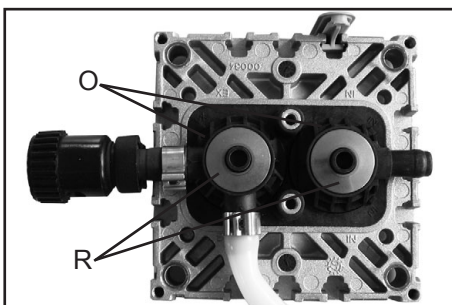

- Position valve heads (O), with hose nozzle (P), if applicable, connection tube or connection fastener (Q), and disc springs (R) on the valve seats. Position disc springs with large opening downwards. Pay attention to the correct orientation of the valve heads.
- ☞ Center the valve head with respect to the valve seat. The valve head must lie flat on the valve seat.

### Valve head with gas ballast or hose nozzle connection:

- Insert square nut (K) in the groove of the head cover (J) or position square nut in the groove and then screw on connection fastener.
- ☞ Loosely fasten fillister head screw (L).

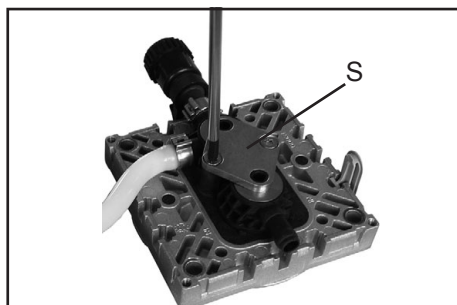

- Position clamping bracket (S) with countersunk bores facing upwards.
- Align the countersunk bores with the threaded pegs.
- Loosely fasten the countersunk screws and correct the alignment of the valve heads if necessary.

- Tighten countersunk screws with Torx screwdriver T20.
- ☞ Torque: 2.2 ft·lb<sub>f</sub> (3 Nm).

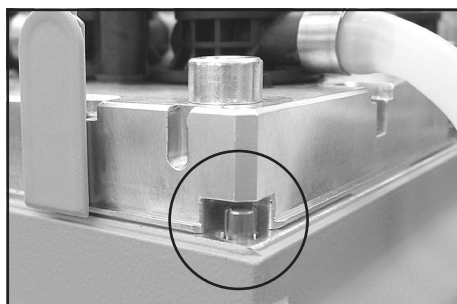

- Bring the diaphragms (F) into a position, in which they are in contact with the housing (C) and centered with respect to the bore.
- Put on head cover (J) with valve heads (O) and connections attached.
- ☞ Pay attention to the correct orientation of the head covers:

Housing with head alignment pin: The head alignment pin (A) at the pump housing (C) has to fit into the recess at the head cover (J).

Housing with mark (A): Align the recess at the head cover with the mark at the pump housing.

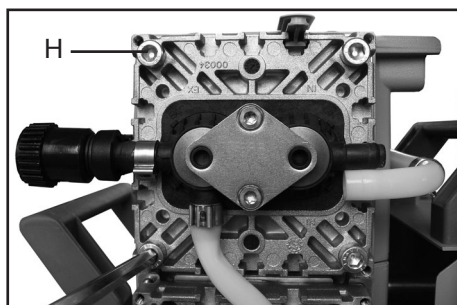

- Loosely screw in the Allen head screws (H) at the head covers diagonally at first slightly with a 5 mm wide Allen key, then tighten.
- ☞ Recommended torque: 8.9 ft·lb<sub>f</sub> (12 Nm).
- Slide the caps (I) into the head cover.

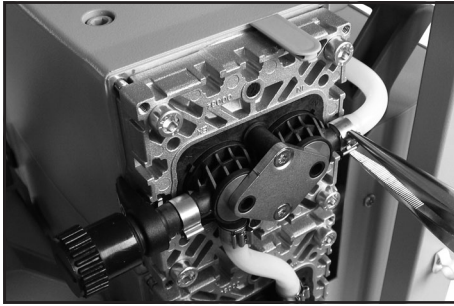

Affix the connection tube (V) to the other side of the pump at the valve head (O).

**Pump on pump support:**

Affix the connection tube (V) to the other side of the pump, as well as the hose connection to the inlet or outlet of the vacuum system at the valve head (O).

- Slip connecting tube (V) onto hose connection of valve head.
- Slide on the tube and the hose clip (U) until touching the nose at the valve head.
- Close hose clip (U) with flat pliers.

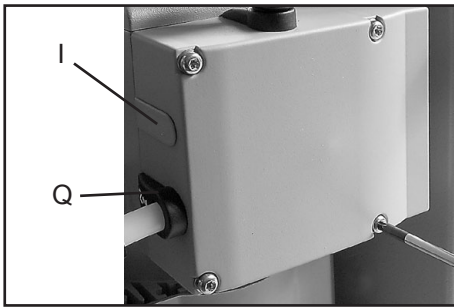

- Put head cover cowling on.
- Slide the head cover cowling in the grooves of the caps (I) and under the connection fasteners (Q).
- Install the washers. Use a Torx driver T20 to attach the 4 screws holding the head cover cowling.

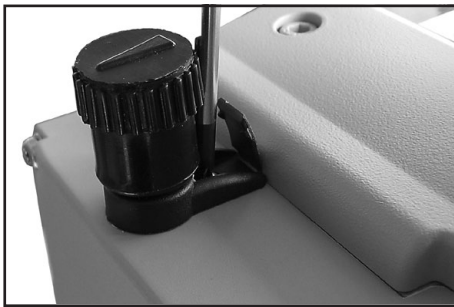

- Tighten the fillister head screws (L) of the connection fasteners (Q) with a Torx driver T20.
- Close the hinged covers.

**Replace diaphragms and valves of the opposite side of the pump in the same way!**



**Pump at pump support:**

- Assemble catchpots (9) with joint clips.

## Checking the ultimate vacuum

- After any intervention at the equipment (e.g., repair / maintenance) the ultimate vacuum of the pump has to be checked. Only if the pump achieves its specified ultimate vacuum, the pump's leak rate is low enough to ensure that no explosive atmospheres will occur in the interior of the equipment.

### **If the pump does not achieve the ultimate vacuum:**

- Whenever the diaphragms and valves have been replaced, a break-in period of several hours is required before the pump achieves its ultimate vacuum.
- In case of an unusual noise, switch off pump immediately and check clamping disc positions.

If the specified ultimate vacuum is not achieved, and if this does not change after the break-in period:

Check hose connectors at pump heads for leaks. If necessary recheck valve seats and pump chambers.

## Replacing the overpressure safety relief device

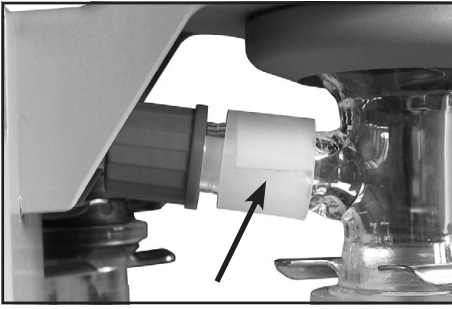

### Overpressure safety relief device ..... 638821 (at exhaust waste vapor condenser)

- Remove catchpot (9) at outlet (see "Use and operation", pg. 38).
  - Loosen the union nut at the inlet of the exhaust vapor condenser.
- 
- 
- Remove the 4 screws affixing the counter holder of the exhaust vapor condenser with a Torx driver T10. Remove the exhaust vapor condenser. In doing so pull the PTFE hose out of the inlet of the exhaust vapor condenser.
  - If necessary, pull off the old pressure relief valve and install the new one. Check for correct position of the PTFE-foil under the pressure relief valve.
  - Feed the PTFE hose into the inlet of the exhaust vapor condenser. Mount the condenser with the counter holder (Torx screws T10) to the pump. Fasten union nut.

## Replacing the fuse

**! DANGER**



- ➔ **Switch off the pump.**
- ➔ **Disconnect the electrical power cord** before opening the terminal box. After disconnecting from power, **wait two minutes** to allow the capacitors to discharge.

**! WARNING**

- ☞ The replacing of the fuse has to be carried out by a trained electrician.
- ☞ After replacing the fuse, the pump must be checked for electric safety (see below)! Identify and eliminate the cause of failure before switching on the pump again.



The pigtail fuses are integrated into wires ((1), black and blue) inside the terminal box. To replace the fuses it is necessary to replace both wires completely (fixed with flat pin bushings (2)).

- ➔ Open the terminal box. Unscrew the four screws with a Torx driver T20. Remove the terminal box cover. Remove both wires with integrated fuses (fixed with flat pin bushings (2), see figure). Mount the new wires (flat pin bushings) and close the terminal box. Fasten the cover with the four screws.

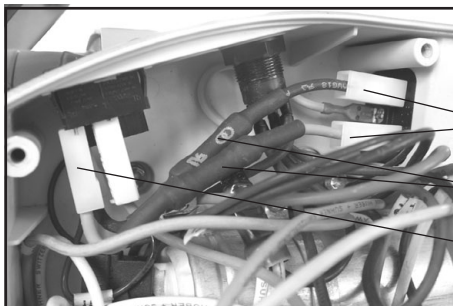

Order-no. Set of fuses NT.....636542

**! WARNING**

**Important: Check operability and safety of the pump after repair and after replacing the device fuse.**

Check the electrical safety (protective conductor resistance, insulating resistance, high voltage test) according to IEC 61010 and national regulations.

# Notes on return to the factory

## Repair - return - DAkkS calibration

### **NOTICE**

Safety and health of our staff, laws and regulations regarding the handling of dangerous goods, occupational health and safety regulations and regulations regarding safe disposal of waste require that for all pumps and other products, the “**Health and safety clearance form**“, see pg. 72, must be sent to our office fully completed and signed before any equipment is shipped to the authorized service center.

Fax or mail a completed copy of the health and safety clearance form to us in advance. The declaration must arrive before the equipment. **Enclose a second completed copy with the product.** If the equipment is contaminated, you must notify the carrier.

**No repair / DAkkS calibration is possible unless the correctly completed form is returned. Inevitably, there will be a delay in processing the equipment if information is missing, or if this procedure is not followed.**

### **CAUTION**

If the product has come in contact with chemicals, radioactive substances or other substances dangerous to health or environment, the product must be decontaminated **prior to sending it back to the service center.**

- Return the product to us disassembled and cleaned and accompanied by a certificate verifying decontamination or
- Contact an industrial cleaning and **decontamination service** directly or
- Authorize us to send the product to an industrial cleaning facility **at your expense.**

To expedite repair and to reduce costs, please enclose a detailed description of the problem and the product's operating conditions with every product returned for repair.

We submit **repair quotations** only on request and always at the customer's expense. If an order is placed, the costs incurred for problem diagnosis are offset from the costs for repair or from the purchase price, if the customer prefers to buy a new product instead of repairing the defective one.

- **If you do not wish a repair on the basis of our quotation, the equipment may be returned to you disassembled and at your expense.**

In many cases, the **components must be cleaned in the factory** prior to repair.

For cleaning we use an environmentally friendly water-based process. Unfortunately the combined attack of elevated temperature, cleaning agent, ultrasonic treatment and mechanical stress (from pressurized water) may result in damage to the paint. Please mark in the health and safety clearance form, if you wish a **repaint at your expense** just in case such a damage should occur.

We will also replace parts for cosmetic reasons at your request and at your expense.

## **NOTICE**

Before returning the equipment, ensure that (if applicable):

- Oil sealed pumps: Oil has been drained and an adequate quantity of fresh oil has been filled in to protect against corrosion. Dispose according to regulations.
- Equipment has been cleaned and/or decontaminated (inside and outside).
- All inlet and outlet ports have been capped.
- Equipment has been properly packed, (if necessary, please order original packaging materials at your cost), marked appropriately and the carrier has been notified of any possible contamination.
- The completed health and safety clearance form is enclosed.

We thank you in advance for your understanding of the necessity for these measures that protect our employees, and ensure that your pump is protected in shipment.

**Scrapping and waste disposal:**

Dispose of the equipment and any components removed from it safely in accordance with all local and national safety and environmental requirements. Particular care must be taken with components and waste oil which have been contaminated with dangerous substances from your processes. Do not incinerate fluoroelastomer seals and O-rings.

- You may authorize us to dispose of the equipment **at your expense.**

# Warranty

VACUUBRAND shall be liable for insuring that this product, including any agreed installation, has been free of defects at the time of the transfer of risk.

VACUUBRAND shall not be liable for the consequences of improper handling, use, servicing or operation of this product or the consequences of normal wear and tear of wearing parts such as diaphragms, seals, valves, vanes, condensers, oil and the breakage of glass or ceramic parts, for the consequences of chemical, electrochemical or electrical influences or the failure to follow the instructions in this manual.

Claims for defects against VACUUBRAND shall be limited to one year from delivery. The same shall apply to claims for damages irrespective of legal grounds.

For further information on general terms and conditions refer to [www.vacuubrand.com](http://www.vacuubrand.com).

# Health and safety clearance form



Devices will not be accepted for any handling before we have received this declaration. Please read and comply with "Notes on return to the factory".  
Oil filled pumps: Drain oil prior to shipping absolutely!

1. Device (Model): ..... 2. Serial no.: .....

3. Reason for return / malfunction:

.....

4. Has the device been used in a copper process step (e.g., semiconductor production).  yes  no

5. Substances (gases, liquids, solids) in contact with the device / which have been pumped:

.....

.....

.....

6. Prior to return to the factory the device has been decontaminated.  yes  no  
Description of the decontamination method and the test / verification procedure:

.....

.....

7. The device is free of hazardous, harmful substances.  yes  no

8. Protective measures required for VACUUBRAND employees:

.....

9. If the paint is damaged, we wish a repaint or a replacement of parts for reason of appearance (repaint and replacement at customer's expense).  yes  no

## 10. Legally binding declaration

We assure for the returned device that all substances, which have been in contact with the device are listed in section 5 and that the information is complete and that we have not withheld any information. We declare that all measures - where applicable - have been taken listed in section "Return to the factory". By our signature below, we acknowledge that we accept liability for any damage caused by providing incomplete or incorrect information and that we shall indemnify VACUUBRAND from any claims as regards damages from third parties. We are aware that as expressed in § 823 BGB (Public Law Code of Germany) we are directly liable for injuries or damages suffered by third parties, particularly VACUUBRAND employees occupied with handling/repairing the product.  
Shipping of the device must take place according to regulations.

Name: ..... Signature: .....

Job title: ..... Company's seal:

Date: .....

Release for repair grant by VACUUBRAND (date / signature): .....



**EG-Konformitätserklärung für Maschinen  
EC Declaration of Conformity of the Machinery  
Déclaration CE de conformité des machines**

Hersteller / Manufacturer / Fabricant:  
VACUUBRAND GMBH + CO KG · Alfred-Zippe-Str. 4 · 97877 Wertheim · Germany

Hiermit erklärt der Hersteller, dass die Maschine konform ist mit den Bestimmungen der Richtlinie 2006/42/EG. Hereby the manufacturer declares that the machinery is in conformity with the directive 2006/42/EC.

Par la présente, le fabricant déclare, que la machine est conforme à directive 2006/42/CE.

Membranvakuumpumpe / Diaphragm vacuum pump / Pompe à membrane:  
Typ / Type / Type: ME 2C NT / ME 4C NT / ME 4C NT + 2 AK / MZ 2C NT / MZ 2C NT + 2 AK / MZ 2C NT + AK + EK / MZ 2C NT + AK + M + D / MZ 2C NT + AK SYNCHRO + EK / PC 101 NT / ME 8C NT / ME 8C NT + 2 AK / MD 4C NT / MD 4C NT + 2 AK / MD 4C NT + AK + EK / MD 4C NT + AK SYNCHRO + EK / PC 201 NT

Artikelnummer / Order number / Numéro d'article: 730100, 730102, 730105 / 731200, 731201, 731202 / 2614080 / 732300, 732301, 732302, 732345 / 732500, 732501, 732502, 732510, 2614708 / 732600, 732601, 732602, 732615 / 732700, 732701, 732702 / 732800, 732801, 732802 / 733000, 733001, 733002 / 734200, 734201, 734202 / 734405 / 736400, 736401, 736402, 2614826 / 736600, 736601, 736602 / 736700, 736701, 736702, 736710, 2613972 / 736800, 736801, 736802 / 737000, 737001, 737002

Seriennummer / Serial number / Numéro de série: Siehe Typenschild / See rating plate / Voir plaque signalétique

Die Maschine ist konform mit weiteren Richtlinien / The machinery is in conformity with other directives / La machine est conforme à d'autres directives:  
2006/95/EG, 2004/108/EG, 94/9/EG

Angewandte harmonisierte Normen / Harmonized standards applied / Normes harmonisées utilisées:  
DIN EN 12100, DIN EN 61010-1, DIN EN 1012-2, DIN EN 61326-1, DIN EN 1127-1, EN 13463-1

Bevollmächtigter für die Zusammenstellung der technischen Unterlagen / Person authorised to compile the technical file / Personne autorisée à constituer le dossier technique:  
Dr. J. Dirscherl · VACUUBRAND GMBH + CO KG · Alfred-Zippe-Str. 4 · 97877 Wertheim · Germany

Wertheim, 03.01.2012  
.....  
ort, Datum / place, date / lieu, date

  
.....  
(Dr. F. Gitmans)  
Managing director / Gérant

ppa.   
.....  
(Dr. J. Dirscherl)  
Technical Director / Directeur technique

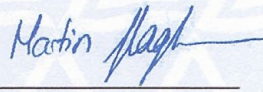

VACUUBRAND GMBH + CO KG  
Alfred-Zippe-Str. 4 · 97877 Wertheim  
T +49 9342 808-0 · F +49 9342 808-5555  
info@vacuubrand.com  
www.vacuubrand.com

<h1>Certificate</h1>		 <b>TÜVRheinland®</b>
Certificate no. <span style="border: 1px solid black; padding: 2px;">CU 72081689 01</span>		
<b>License Holder:</b> VACUUBRAND GMBH + Co. KG Alfred-Zippe-Str. 4  97877 Wertheim Germany	<b>Manufacturing Plant:</b> VACUUBRAND GMBH + Co. KG Alfred-Zippe-Str. 4  97877 Wertheim Germany	
<b>Test report no.:</b> USA-DS 30882017 001	<b>Client Reference:</b> M. von Przychowski	
<b>Tested to:</b> UL 61010A-1:2002 R12.02 CAN/CSA-C22.2 No. 1010.1-92+A2:97		
<b>Certified Product:</b> Diaphragm Vacuum Pump for Laboratory Use	<b>License Fee - Units</b>	
Model Designation: Mw xyyy NT yy z, PC 101 NT, PC 201 NT (w=E,Z,D,V; x=2,4,6,8; y=A-Z, blank; z=+AK, +EK, +2AK, +AK+EK, +AK+EK TE, +AK+EK Peltronik, +AK SYNCHRO+EK, +AK+M+D, +IK+EK, blank)	7	
Rated Voltage: 1) AC 100V, 50/60Hz; 2) AC 120V, 60Hz 3,4) AC 230V, 50/60Hz; 5,6) AC 100-115V, 50/60Hz; AC 120V, 60Hz 7,8) AC 100-115/200-230V, 50/60Hz; AC 120V, 60Hz		
Rated Current: 1) 5A; 2) 4A; 3) 3A; 4) 1.8A; 5) 5.7A; 6) 3.4A; 7) 5.7/3.0A, 5.7A; 8) 3.4/1.8A, 3.4A		
Protection Class: I		
Appendix: 1, 1-2	7	
<b>Licensed Test mark:</b> 	<b>Signature</b>  <b>Dipl.-Ing. M. Glagla</b> QA Certification Officer	<b>Date of Issue</b> (day/mo/yr) 08/09/2008
<small>TUV Rheinland of North America, Inc., 12 Commerce Road, Newtown, CT 06470, Tel: (203) 426-0888 Fax: (203) 426-4099</small>		

**This certificate is only valid for pumps with the respective mark (Licensed Test mark) on the pump rating plate.**

Disclaimer: Our technical literature is only intended to inform our customer. The applicability of general empirical values and results obtained under lab conditions to your specific operations depends on a number of factors beyond our control. It is, therefore, strictly the users' responsibility to very carefully check the application of these data to their specific requirements. No claims arising from the information provided in this literature will, consequently, be entertained.



Alfred-Zippe-Str. 4 · 97877 Wertheim / Germany  
T +49 9342 808-0 · F +49 9342 808-5555  
info@vacuubrand.com · www.vacuubrand.com

**VACUUBRAND GMBH + CO KG**  
- Technology for Vacuum Systems -  
© 2012 VACUUBRAND GMBH + CO KG Printed in Germany