



Please read user's manual
before operating equipment

Original Instructions

LABCONCO CORPORATION

8811 Prospect Avenue

Kansas City, MO 64132

(800) 821-5525 | +1 (816) 333-8811

Technical Manual

SteamScrubber® FlaskScrubber®

FlaskScrubber® Vantage®

Glassware Washer



Register this product

SteamScrubber® Glassware Washers

2021—Present

4010010xx 4020010xx

4011010xx 4021010xx

FlaskScrubber® Glassware Washers

2021—Present

4110010xx 4120010xx

4111010xx 4121010xx

FlaskScrubber® Vantage®

Glassware Washers

2021—Present

422101010 422101013

Copyright © 2020 Labconco Corporation. The information contained in this manual and the accompanying products are copyrighted, and all rights reserved by Labconco Corporation. Labconco Corporation reserves the right to make periodic design changes without obligation to notify any person or entity of such change.

Warranty

Labconco Corporation provides a warranty to the original buyer for the repair or replacement of parts and reasonable labor as a result of normal and proper use of the equipment with compatible chemicals. Broken glassware and maintenance items, such as filters, gaskets, light bulbs, finishes and lubrication are not warranted. Excluded from warranty are products with improper installation, erratic electrical or utility supply, unauthorized repair, use with incompatible chemicals, or non-factory modifications to the original product.

SteamScrubber, FlaskScrubber and FlaskScrubber Vantage Glassware Washers carry a two-year warranty from date of installation or three years from date of shipment from Labconco, whichever is sooner. Warranty is non-transferable and only applies to the owner (organization) of record.

Buyer is exclusively responsible for the set-up, installation, verification, decontamination or calibration of equipment. This limited warranty covers parts and labor, but not transportation and insurance charges. If the failure is determined to be covered under this warranty, the dealer or Labconco Corporation will authorize repair or replacement of all defective parts to restore the unit to operation. Repairs may be completed by 3rd party service agents approved by Labconco Corporation. Labconco Corporation reserves the rights to limit this warranty based on a service agent's travel, working hours, the site's entry restrictions and unobstructed access to serviceable components of the product.

Under no circumstances shall Labconco Corporation be liable for indirect, consequential, or special damages of any kind. This warranty is exclusive and in lieu of all other warranties whether oral, or implied.

Returned or Damaged Goods

Do not return goods without the prior authorization from Labconco. Unauthorized returns will not be accepted. If your shipment was damaged in transit, you must file a claim directly with the freight carrier. Labconco Corporation and its dealers are not responsible for shipping damages.

The United States Interstate Commerce Commission rules require that claims be filed with the delivery carrier within **fifteen (15) days** of delivery.

Limitation of Liability

The disposal and/or emission of substances used in connection with this equipment may be governed by various federal, state, or local regulations. All users of this equipment are required to become familiar with any regulations that apply in the user's area concerning the dumping of waste materials in or upon water, land, or air and to comply with such regulations. Labconco Corporation is held harmless with respect to user's compliance with such regulations.

For additional questions or support:

Labconco Customer Care +1 (816) 333-8811

Labconco Technical Support (800) 821-5525

Hours 7:30 a.m.-5:30 p.m. CST

Part #4684900 Rev. C

ECO 15214

Table of Contents

1: INTRODUCTION	12
Contacting Labconco	12
About This Manual	12
Theory of Operation	13
2: SAFETY PRECAUTIONS	14
Typographical Conventions	14
General Safety Precautions	17
Safety Precautions for this Product	18
3: PRODUCT IDENTIFICATION	21
Model and Serial Numbers	21
Serial Tag Location	21
Primary Serial Tag	22
Secondary Serial Tag	22
About Screen	22
Configurator	23
4: NAVIGATING THE GLASSWARE WASHER	24
Control Panel	24
Touch Screen Display	24
Open Button	24
On / Standby LED Indicator	25

Initial Power Up	25
Power Reset	25
Opening the door with no power	25
Home Screen	26
Screen Indicator Bar	27
Program Selection	27
Start Program	27
Program Progress	28
Skip Segment	28
Pause	28
Cancel	28
Program Screen	29
Log Data	29
View Data File	30
Chart Data File	32
Export Data File	33
Delete Data File	33
Settings	34
Language	34
Security	35
Calibration - Offsets	36
Calibration - Setpoints	37
Time & Date	37
Alerts	38
Display	40
Units	41
Maintenance	42
Factory Maintenance	42

Factory Water Fill Level Calibration and Water Level Pressure Switch Test	43
Factory Auto Dispense Calibration	45
Reset Lifetime Counts to Zero	46
Factory Reset	46
Network	46
Customize	48
Data Logs	49
Sensors	50
Accessories	51
Help	51
About	52
Software Update via USB Thumb drive	53
Software Update via Ethernet (Push)	53
Software Update via the Ethernet (Pull)	53
Automatic Update Notification	54
Diagnostics	54
Resources	55
Backup and Restore	56
Notification	57
5: MAINTENANCE	58
Maintenance Safety Precautions	58
Recommended Maintenance Schedule	59
Maintaining the Stainless-Steel Surfaces	59
Clean Washer Cycle	60
Maintaining the Air Gap in Drain	60
Maintaining the Water Fill Valve	60

Cleaning the Sump and Sump Filter Screen	61
Replacing the HEPA Filter (PN4597300) (FlaskScrubber Vantage only)	62
Maintaining the Conductivity Sensor (FlaskScrubber Vantage only)	63
Cleaning the Conductivity Sensor	64

6: MODIFICATIONS **65**

Washer Rack Configuration	65
Installing the upper rack slides	65
Remove the upper rack	66
Replace the upper rack	66
Raise the upper rack height	67
Lower the upper rack height	67
FlaskScrubber Spindle Rack	68
Liquid Detergent and Neutralizing Acid Rinse Dispense Systems	69
Installing the Liquid Detergent and Neutralizing Acid Rinse Dispense Systems	69
Using the Liquid Detergent and Neutralizing Acid Rinse Dispense Systems	72
Drain Water Cooling Kit	72
Installation of the Drain Water Cooling Kit	73
Printer Kit for FlaskScrubber and SteamScrubber	74
Installation of Printer Kit	74
Installation of Vantage Printer Kit	75

7: DIAGNOSTICS/TROUBLESHOOTING **76**

Alarms	76
Running Diagnostics	77
Fill All-The-Way	78
Pure Fill All-The-Way	79
Drain All-The-Way	79

Wash Pump 1	80
Heater 1	80
Heater 2&3 (High Heat Models only)	80
Drain Valve	80
Drain Pump	80
Manual/Auto Run Test	80
Fill Valve (Hot Tap)	81
DI Valve (Pure)	81
DI Pump (Pure)	81
Detergent Cup	81
Dry Blower	81
Electronic Cooling Fan	81
LED Light (If equipped)	82
Printer (If equipped)	82
Detergent Pump 1 (If equipped)	82
Rinse Aid Pump 1 (If equipped)	82
Door Latch	82
Diagnostic Report	82

8: SERVICE PROCEDURES **95**

Maintenance Safety Precautions	95
Washer Layout and Landmarks	96
Removing the Toe Kick Panels, Service Panels and Door Assembly	97
Remove the Door Panels and Toe Kick Panels	98
Removing the Back and Side Service Panels (Undercounter Models)	99
Removing the Washer Top, Back, and Side Panels (Free-Standing Models)	99
Removing the Door Assembly	99
Replacing or Adjusting the Door Latch, Latch Striker, Hinge Pins	100

Adjusting the Striker	100
Replacing or Adjusting the Latch Assembly	100
Adjusting the Door Hinge Pins	101
Door Gasket Replacement	102
Replacing the Washer LED Light	103
Replacing the Detergent and Acid Rinse Dispenser	104
Replacing the Electronic Control Components	105
Replacing the Display Board Assembly	105
Replacing the Input/Output Board (IOB)	107
Replacing the Power Supply	108
Replacing Electronic Enclosure Components	109
Replacing Water Level Pressure Switch(Prior to 8/23, cat. # rev J)	110
Replacing Overfill Water Level Sensor(After 9/23 cat. # rev. P)	111
Replacing Heating Elements	114
Replacing Heater 1	114
Replacing Heater 2&3	115
Replacing Pumps	116
Replacing Wash Pump	116
Replacing the Wash Pump on a FlaskScrubber Vantage	118
Replacing the Pure Water Pump	118
Replacing the Drain Pump	119
Replacing the Vantage Detergent and Rinse Aid Pumps	119
Replacing Valves	120
Replacing Hot Tap or Pure Water Valves	120
Replacing Drain Valve	120
Replacing the Blower	121
Replacing the Dry Blower on a SteamScrubber	121
Replacing the Dry Blower on a FlaskScrubber	122

Replacing the Dry Blower on a FlaskScrubber Vantage	122
Cleaning or Replacing the Wash Arms	123
Replacing the Rack Valve Bushing	124
Adjusting Rack Bumpers	124

9: ACCESSORIES & CONSUMABLES **125**

Rack Inserts for Labware	125
Racks	126
Rack Accessories	127
Heater Cover Kit	127
Liquid Detergent and Rinse Aid Dispensers	128
Cool Drain Water Kit	128
Base Stand	128
Printer Kit	129
RO Storage Tank	129
ScrubberMate Cart	129
Freestanding Conversion Kit	130
Consumables	130

APPENDIX A: PARTS LIST **131**

Parts List	132
------------	-----

APPENDIX B: DIMENSIONS **134**

Undercounter Exterior Dimensions	134
Freestanding Exterior Dimensions	134
SteamScrubber Interior Dimensions	135

FlaskScrubber Interior Dimensions	135
FlaskScrubber Vantage Exterior Dimensions	136
FlaskScrubber Vantage Interior Dimensions	136

APPENDIX C: SPECIFICATIONS **137**

Programs	137
Power Data	139
Fill and Heat Specifications	139
Environmental Conditions	140

APPENDIX D: WIRING DIAGRAMS **141**

1: Introduction

This manual is designed for glassware washer servicers. Labconco has compiled this information to use in the servicing of our SteamScrubber, FlaskScrubber and FlaskScrubber Vantage Glassware Washers.

As always, we at Labconco want to assist you in a better understanding of our products and their operation; if you have any questions, or need additional information, please contact us.

Thank you for all your support in the past, and in the future.

Contacting Labconco

LABCONCO Corporation
8811 Prospect Avenue
Kansas City, MO 64132
USA

Our hours of operation are from 7:30 am - 5:30 pm CST, Monday through Friday, except national holidays

Should you require technical assistance, service parts, or have general questions regarding the product we can be reached at the following numbers, the operator can help direct your calls to the proper associate.

We can be reached at the following numbers:
1 (800) 821-5525 +1 (816) 333-8811

About This Manual



This manual contains important operation and safety information. When you see a symbol, such as the INFO symbol to the left, pay close attention to the information provided. Before installing or operating this product, you must read [Section 3: Safety Precautions](#).

Theory of Operation

The Labconco Glassware Washers were re-engineered in 2020, with the new line available in January of 2021. The new generation of Glassware Washers include updated features and modifications that set it apart from the previous generations.

Some of these updates include (but are not limited to): an interactive touch screen display, three separate pumps for wash, drain and pure water, a water level pressure sensor, forced air blowers for drying, printer and ethernet capabilities, USB port for software updates and data collection.

The three basic models of Labconco Glassware Washers are, FlaskScrubber, SteamScrubber, and FlaskScrubber Vantage. The FlaskScrubber and SteamScrubber are available in 115 Volt 1.2Kw, 230 Volt 2.0Kw single phase or 230 Volt 6.0Kw 3 phase power options. They can be ordered as Under-Counter (UC) or Free-Standing (FS) configurations. An optional viewing window is also available.

The FlaskScrubber® and FlaskScrubber Vantage use a direct jet manifold system for washing, rinsing, and drying. They both include a Lower Spindle Rack. The spindles on this rack can be swapped out with different sizes (tall, short, and thin) or removed to create a flat rack.

The SteamScrubber includes both an upper and lower open rack. The racks can accommodate a wide variety of accessories to contain specific types of lab-ware. Drying is performed through an integrated blower circulating forced, heated air through the tank.

The FlaskScrubber Vantage sets itself apart from the rest, as Labconco's full featured Laboratory Glassware Washer. It is available in 230 Volt 2.0 Kw single phase or 230 Volt 6.0 Kw three phase configurations. It comes standard as a freestanding model with viewing window. It includes a conductivity sensor to monitor water quality. The built-in side cabinet houses the HEPA filter used for forced air drying, plus the Liquid Detergent, and Acid Neutralizing Rinse Pump systems.

This document serves to provide service technicians and users with supplementary instructions for the care and service of these washers.

2: Safety Precautions

Before unpacking, installing, operating, maintaining, or servicing this equipment, read the following safety warnings and precautions.

Avant le déballage, l'installation, le fonctionnement, l'entretien ou la maintenance de cet équipement, lire les avertissements de sécurité et les précautions d'emploi.



CAUTION – See Manual. When this symbol is on the equipment, it indicates a caution that is detailed in this manual.

MISE EN GARDE – Voir le manuel. Lorsque ce symbole est apposé sur l'équipement, il renvoie à une mise en garde détaillée dans ce manuel.

Typographical Conventions



DANGER – An imminently hazardous situation which, if not avoided, will result in death or serious injury.

DANGER – Situation dangereuse imminente qui, si elle n'est pas évitée, peut entraîner la mort ou des blessures graves.



CAUTION – Indicates a potentially hazardous situation which, if not avoided, may result in minor or moderate injury or damage to property.

MISE EN GARDE – Signale une situation potentiellement dangereuse qui, si elle n'est pas évitée, peut provoquer des blessures mineures à modérées ou des dommages matériels.



NOTE – Advice or suggestions to help the process.

REMARQUE – Conseils ou suggestions pour le déroulement du processus.



BURN RISK (HIGH TEMPERATURE) – Air or components that will be very hot. Take care not to touch these defined areas. Failure to avoid these areas may result in moderate to severe injury.

RISQUE DE BRÛLURE (TEMPÉRATURE ÉLEVÉE) – Air ambiant ou composant devenant très chaud. Veiller à ne pas toucher ces zones délimitées. L'absence de précaution pour éviter ces zones peut entraîner des blessures modérées, voire graves.



EXTREME COLD (LOW TEMPERATURE) – Air or components that will be very COLD. Take care not to touch these defined areas. Failure to avoid these areas may result in moderate to severe injury.

FROID INTENSE (TEMPÉRATURE BASSE) – Air ambiant ou composant devenant très froid. Veiller à ne pas toucher ces zones délimitées. L'absence de précaution pour éviter ces zones peut entraîner des blessures modérées voire graves.



PINCH POINT – Areas or components that can pinch or cut. Take care not to touch these defined areas.

POINT DE PINCEMENT – Zones ou composants présentant un risque de pincement ou de coupure. Veiller à ne pas toucher ces zones délimitées.



MOVING PARTS – Areas or components that contain moving parts. Take care not to touch these defined areas.

PIÈCES MOBILES – Zones ou composants contenant des pièces mobiles. Veiller à ne pas toucher ces zones délimitées.



RISK OF ELECTRICAL SHOCK – The specified procedure or area poses a risk of electrical shock. ALWAYS disconnect main power cord or electrical supply before proceeding.

RISQUE DE CHOC ÉLECTRIQUE – La procédure ou la zone spécifiée présente un risque de choc électrique. TOUJOURS débrancher le cordon d'alimentation secteur ou l'alimentation électrique avant toute intervention.



FLAMMABLE / NO SOLVENTS – Do not place flammable liquids or solvents in this product.

INFLAMMABLE / PAS DE SOLVANTS – Ne placez aucun liquid inflammable dans cette produit.



LIFTING HAZARD – Do not lift or move this equipment without assistance.

DANGER DE LEVAGE – Ne pas soulever ou déplacer cet équipement sans assistance.



MAGNETIC FIELD IN USE – Magnets or magnetic field present.

CHAMP MAGNETIQUE UTILISE – Présence d'aimants ou de champ magnétique.



DO NOT TOUCH – Components or areas indicated are sensitive and will suffer damage if touched. Take care not to touch these defined components or areas. Failure to avoid these areas will result in damage to the product.

NE PAS TOUCHER – Les composants ou les zones indiquées sont sensibles et subiront des dégâts s'ils sont touchés. Veiller à ne pas toucher ces composants ou zones délimité(e)s. L'absence de précaution pour éviter ces zones endommagera le produit.



TOOL REQUIRED – Tool required to access specified area.

OUTIL NÉCESSAIRE – Outil nécessaire pour accéder à la zone spécifiée.

General Safety Precautions

Follow all the safety precautions described in this section.



Before removing any panels, which require a tool for removal, ALWAYS disconnect the main power cord or electrical supply. Failure to remove all electrical power before proceeding will result in moderate to serious injury, death, or damage to property.

Avant le retrait d'un panneau nécessitant l'utilisation d'un outil, TOUJOURS débrancher le cordon d'alimentation secteur ou l'alimentation électrique. Le non-respect de la consigne consistant à couper complètement l'alimentation électrique avant toute intervention peut entraîner des blessures graves, la mort ou des dommages matériels.



Never contact moving parts with your person. Failure to avoid moving parts will result in moderate to serious injury, death, or damage to property.

Ne jamais toucher les parties mobiles. Le non-respect de la consigne consistant à éviter les pièces mobiles peut entraîner des blessures graves, la mort ou des dommages matériels.



Never misuse this product. Never disable, override, or otherwise bypass safety guards, panels, switches, sensors, or alarms. Doing so will result in moderate to serious injury, death, or damage to this product or property.

Ne jamais utiliser ce produit à mauvais escient. Ne jamais désactiver, annuler ou contourner les capots, panneaux, interrupteurs, capteurs ou alarmes de sécurité. Ceci entraînerait des blessures graves, la mort ou des dommages matériels à ce produit ou à d'autres biens.



If the unit is not operated as specified in this manual it may impair the protection provided by the unit.

Si l'unité n'est pas utilisée comme spécifié dans ce manuel il peut diminuer la protection fournie par l'unité.



Do not position the unit so that it is difficult to operate the main disconnect device.

Ne placez pas l'appareil de sorte qu'il est difficile de faire fonctionner le dispositif principal de déconnexion.



Do not lift or move this equipment without assistance.

Ne pas soulever ou déplacer cet équipement sans assistance.

Safety Precautions for this Product



Do not use any detachable power cord that is not adequately rated for the unit.

Ne pas utiliser un fil électrique amovible qui n'est pas de la tension nominale de l'appareil.



Do not damage internal wiring or other components while service panels are removed. If internal wiring or components are damaged, do not restore power, contact Labconco's Product Service Department immediately.

N'endommagez pas le câblage interne ou d'autres composants lorsque les panneaux de service sont retirés. Si le câblage interne ou les composants sont endommagés, ne rétablissez pas l'alimentation, contactez immédiatement le service après-vente des produits de Labconco.



Wear all required Personnel Protective Equipment (PPE) during service operations. At a minimum, this includes eye protection, breathing protection, skin protection. Do not wear loose fitting clothes that can catch on internal surfaces.

N'endomm Portez tous les équipements de protection du personnel (EPI) requis pendant les opérations d'entretien. Au minimum, cela comprend: la protection des yeux, la protection respiratoire, la protection de la peau. Ne portez pas de vêtements amples qui pourraient s'accrocher aux surfaces internes.



After service, verify safe state of use before using the product. Contact Labconco's Product Service Department for questions on determining safe state of this product.

Après le service, vérifiez l'état de sécurité d'utilisation avant d'utiliser le produit. Contactez le service après-vente des produits de Labconco pour toute question relative à la détermination de l'état de sécurité de ce produit.



Verify protective earth ground continuity before using equipment.

Vérifiez la continuité de la terre de protection avant d'utiliser l'équipement.



No hazards exist for: explosion, implosion, or release of toxic or flammable gases arising from the materials being heated.

Il n'existe aucun danger pour: explosion, implosion ou libération de gaz toxiques ou inflammables provenant des matériaux chauffés



Cleaning solutions that do not contain chlorine-based disinfectants (such as Bleach or hypochlorites) may be safely used on this equipment.

Les solutions de nettoyage qui ne contiennent pas de désinfectants à base de chlore (comme l'eau de Javel ou les hypochlorites) peuvent être utilisées en toute sécurité sur cet équipement.



If there is any doubt about the compatibility of decontamination or cleaning agents, contact Labconco's Applications Department.

En cas de doute sur la compatibilité des agents de décontamination ou de nettoyage, contactez le service après-vente applications des produits Labconco.



To verify door safety interlock is functioning properly, close the washer door until it latches, start a program. Once the wash program has begun, try to pull the door open. Door should not open. Press the open button. The Pause Program? Pop-up should display on touch screen. Press yes. All functionalities must stop. If the wash pump was running the door should unlock after 7 seconds. If this result is not achieved, do not use the product, and contact Labconco's Product Service Department immediately.

Pour vérifier que le verrouillage de sécurité de la porte fonctionne correctement, fermez la porte de la laveuse jusqu'à ce qu'elle se verrouille, démarrez un programme. Une fois le programme de lavage commencé, essayez d'ouvrir la porte. La porte ne doit pas s'ouvrir. Appuyez sur le bouton d'ouverture. Le programme de pause? La fenêtre contextuelle devrait s'afficher sur l'écran tactile. Appuyez sur oui. Toutes les fonctionnalités doivent s'arrêter. Si la pompe de lavage fonctionnait, la porte devrait se déverrouiller après 7 secondes. Si ce résultat n'est pas obtenu, n'utilisez pas le produit et contactez immédiatement le service après-vente de Labconco.



Steam and surfaces within this washer and its contents may become hot enough to cause burns.

La vapeur et les surfaces à l'intérieur de cette laveuse et son contenu peuvent devenir suffisamment chauds pour causer des brûlures.



Do not place any flammable liquids in this washer. Failure to empty and rinse glassware could result in fire or explosion.

Ne placez aucun liquide inflammable dans cette laveuse. Il y a un risque d'incendie ou d'explosion si la verrerie n'est pas vidée ni rincée.



LIFTING HAZARD – Do not lift or move this equipment without assistance.

DANGER DE LEVAGE –

Ne pas soulever ou déplacer cet équipement sans assistance.



The dedicated supply electrical circuit must be wired through an appropriately rated switch suitably located within 10 feet (3m) of the product and easily reachable. The switch must be marked as the disconnecting device for the product.

Le circuit électrique d'alimentation dédié doit être câblé via un interrupteur de calibre approprié situé à moins de 3 m (10 pieds) du produit et facilement accessible. L'interrupteur doit être marqué comme le dispositif de déconnexion du produit.

3: Product Identification

Model and Serial Numbers

In addition to the serial tag, the About Screen has the product model number and serial number. If you need to contact Labconco regarding this product, you will be required to provide the serial number. The serial number provides all product details, including the revision level under which the product was constructed. It is the single, most important piece of information when assistance is requested.

Serial Tag Location

See Figure 3-1 for the location of the primary and secondary serial tags.

Figure 3-1

Serial Tag Information

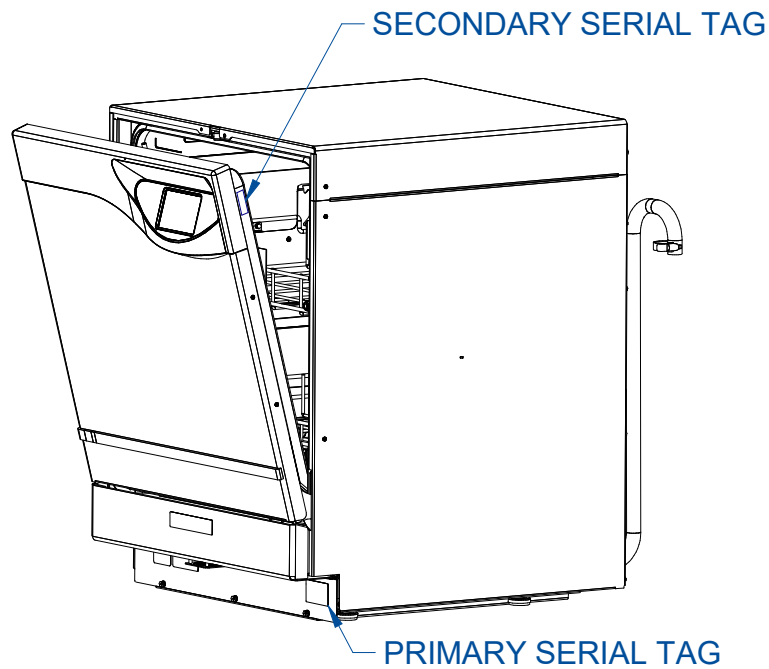

The following information is located on the Serial Tags:

Primary Serial Tag

- Serial Number
- Catalog (Model) Number
- Revision
- Electrical Requirements
 - Voltage
 - Phase
 - Frequency
 - Amperage

Figure 3-2



Secondary Serial Tag

- Serial Number
- Catalog (Model) Number

Figure 3-3



About Screen

The About Screen displays operating system information such as the software version, the catalog number and serial number. Refer to the User's Manual or Help Screen in Chapter 4 for more detailed information.

Figure 3-4

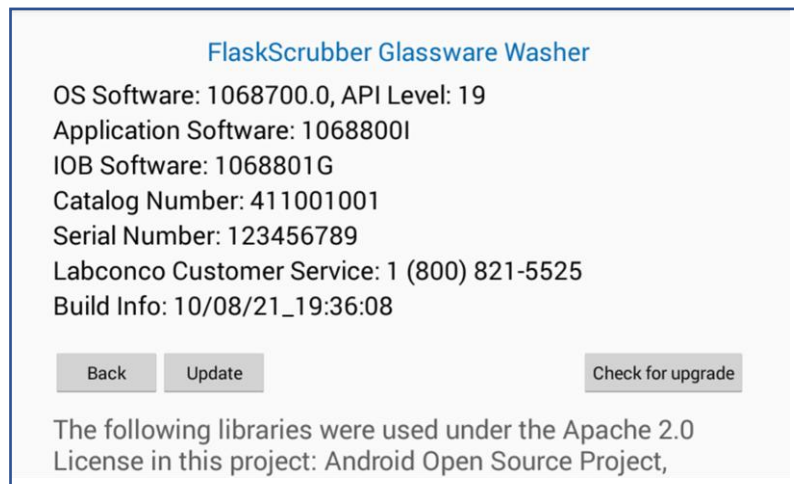

Configurator

Glassware Washers utilize catalog numbers (also referred to as model numbers) some digits of the catalog number provide key information about the model. Use the configurator below to identify specifics about your product. Not all configurations are available.

Figure 3-5

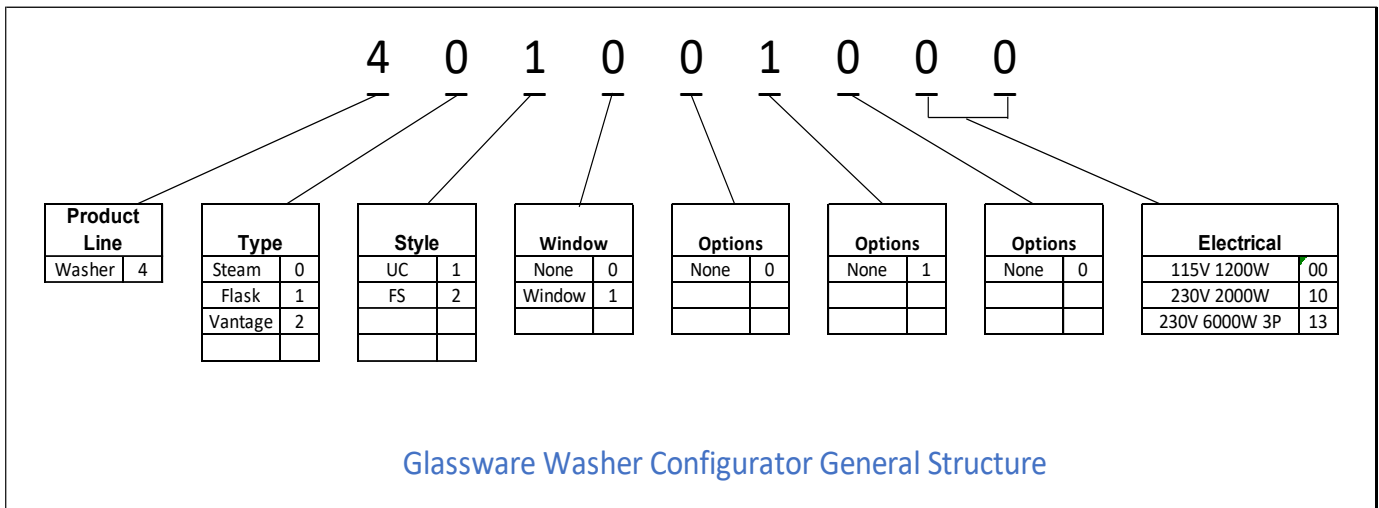

4: Navigating the Glassware Washer

This section will familiarize you with the functions needed to perform various services on the washers. This includes running programs, diagnostic tests, calibration of water levels and auto dispense pumps.

The washer provides a touchscreen display that is pre-programmed with multiple wash cycles. Additional custom programs can be added as required.

The Glassware Washer operating system provides clear status information and user control via the touch screen (Fig. 4-1). To fully understand the features and controls of this product refer to the User's Manual for detailed instructions for each screen.

Control Panel

Figure 4-1



Touch Screen Display

The touch screen displays system operating parameters, set-up parameters and alarm messages. All user-control interface will take place via the touch screen.

Open Button

The display must be active for the door button to operate. If the glassware washer has power and is not in operation, pressing this button will unlatch the door. Pressing this button during a wash cycle will prompt the user for confirmation to pause the cycle and then open the door. Once confirmed, the cycle will pause for 7 seconds to allow the wash pump to stop and then unlatch the door lock. The display must be active for the door button to operate.

On / Standby LED Indicator

Blue LED indicator light designates the current status of the system.

- 1 flash per second = Initial power up (loading operating system)
- Slow pulse = Touch screen in low power mode (screen timeout)
- ON = Unit is plugged in, and touch screen is in active mode
- Off = Unit is unplugged

Initial Power Up

When the glassware washer is initially connected to a power source, the On / Standby LED will begin flashing (1 flash per second). The display will remain OFF for the first 10 to 15 seconds, then animated graphics will appear. It will take approximately 90 seconds for the operating system to fully load.

Power Reset

Use the Open Button to perform a power reset of the unit's control system by pressing and holding for 15 seconds. Power reset can also be accomplished by disconnecting power to the unit.

Opening the door with no power

To open the door if the unit has no power follow the instructions below.

Locate the Door Unlock Pin taped to the Quick Installation Guide in the plastic bag taped to the top of the unit.

Push the Pin into the hole in the control panel until the door opens. See Fig 4-2.

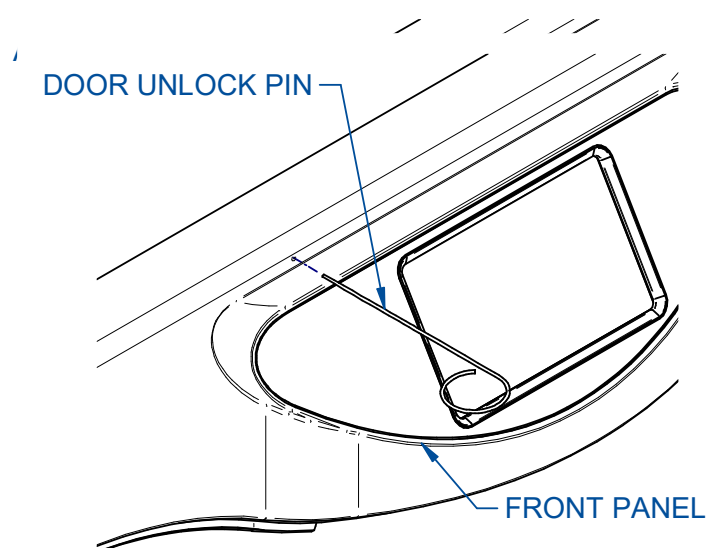

Figure 4-2

Retain the Door Unlock Pin for emergency access to the washer in case of power failure.

Home Screen

After initial power up, the Home screen will be displayed. Most of the general operation and system monitoring can be done from the Home Screen.

Figure 4-3

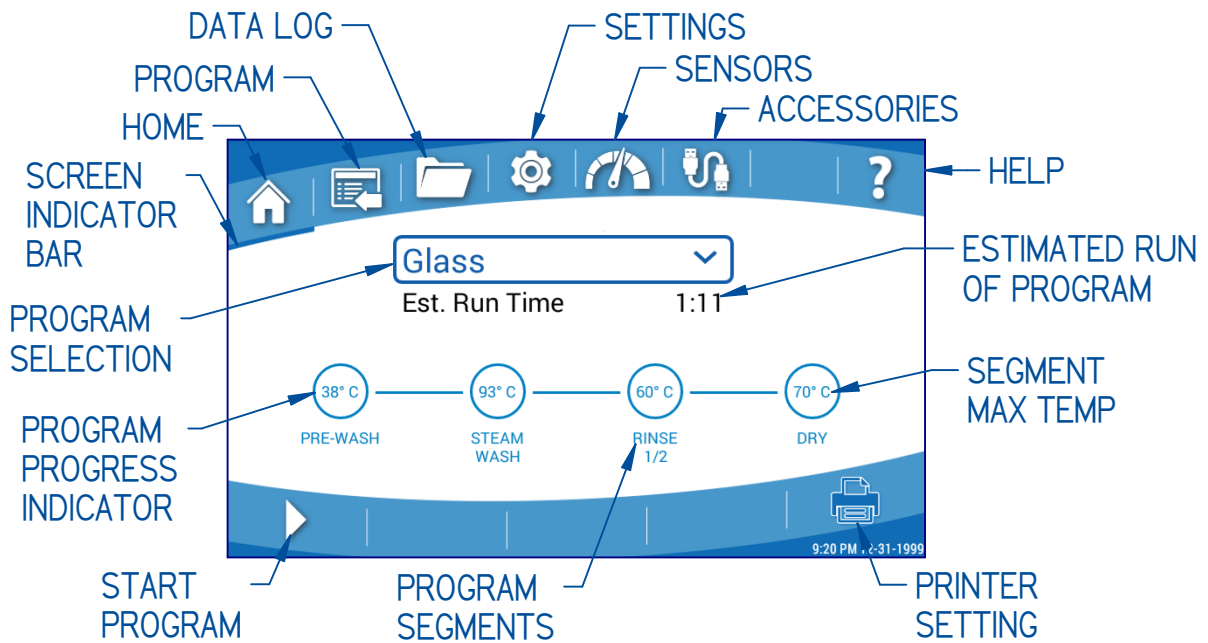

The menu screen tabs are displayed across the top of each screen as shown on the Home Screen in Fig. 4-3.

You can move between menu screens by either touching the desired tab or swiping across the screen from left to right or right to left.

Menu Tabs

- Home
- Programs
- Data Logging
- Settings
- Sensors
- Accessories
- (Empty)
- Help

Screen Indicator Bar

A thin blue indicator bar will appear under the icon of the menu screen that is currently being displayed.

Program Selection

Touch the Program Selection bar to display all programmed cycles. If the list is long, swiping up/down will scroll the list. Touch to select the desired program. The Home Page will then display the Program Progress Indicator for the selected program. The Program Progress Indicator will display each segment of the program, along with the maximum programmed temperature of each segment. The estimated run time will display just beneath the program name.



In the following sections, touchable icons/screen buttons are shown as **[BLUE WITH BRACKETS]**. Screen selections are shown as *green italics*.

Start Program

Touch the *Start Program* Icon (Fig. 4-3). A confirmation pop-up will display, which will show the selected program, the data acquisition rate, the printer format, and any programmed time delay. Time delay settings can be modified from this screen by touching the time and selecting a new delay time. If all settings are correct press **[OK]**

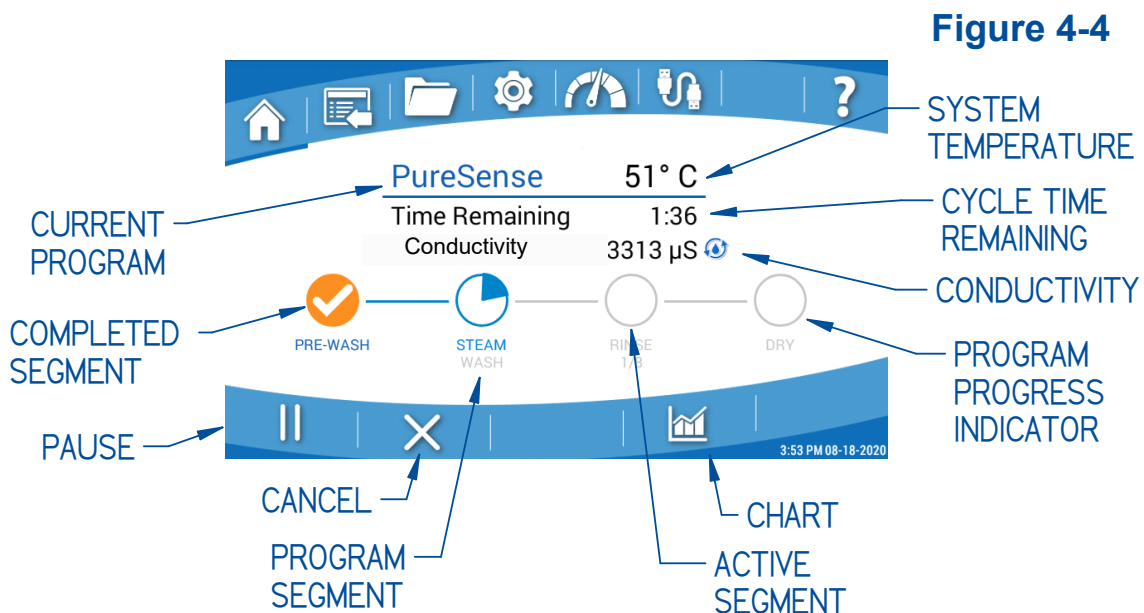

to begin the program. Once the program begins, the Home Screen will change as shown in Fig. 4-4. The system temperature is displayed next to the current running

program, the total estimated time remaining to complete the program and the conductivity level is displayed if equipped.

Program Progress

The Program Progress Indicator graphically displays the progress of each segment of the program as the washer progresses through the cycle. Once a segment is complete, a blue check mark is shown. If a non-fatal alarm occurred during the segment, a yellow check mark is displayed. If the program is canceled or any fatal alarm occurred (automatically ends the cycle) a red **X** will be displayed. A single touch to the Active Segment will display the current segment step and time remaining of that step within the running segment i.e., Fill/Heating/Wash/Drain. The step information will be displayed for 10 seconds, or until the Active Segment is touched again.

Skip Segment

The Glassware washer has the ability to skip an active segment. Press and hold the Active Segment for 3 seconds to display the **SKIP STEP?** confirmation. Touch **[OK]** to skip the active segment. If the skipped segment is a wash or rinse, the glassware washer will perform a drain step and then continue with the next programmed segment. When complete, the Program Progress Indicator will display a yellow check mark at the skipped segment. Press the yellow check mark to display the non-fatal error. A non-fatal Skipped Segment Error (SS) will be recorded in the data log.

Pause

Touch the **Pause** Icon (Fig. 4-4). A confirmation pop-up will display, select **[OK]** to pause the wash cycle, or select **[Cancel]** to return to the Home Screen. The program will stop, and the **Start Program** Icon will return. Once the program is paused the door can be opened by pressing the OPEN button (see Fig. 4-1). To resume the wash cycle, close the door and touch the **Start Program** Icon, press **[OK]** to confirm. The washer will resume the cycle once the internal temperature stabilizes. When the cycle resumes the estimated time remaining will begin when the pre-pause system temperature is reached. When complete, the segment will display a yellow check mark. Press the yellow check mark to display the non-fatal error. A non-fatal Program Paused Error (PP) will be recorded in the data log.

Cancel

Touch the **Cancel** Icon (Fig. 4-4). A confirmation pop-up will display, select **[OK]** to cancel the wash cycle, or select **[Cancel]** to return to the Home Screen. When a program is cancelled the washer will drain and when complete, display a red **X** at the segment in which it was cancelled. Press the red **X** to display the fatal error. A Program Canceled Error (PC) will be recorded in the data log.

Program Screen

The Program Screen allows the user to view the parameters of all programs. New user-defined programs can be created, edited, or deleted from this screen. All factory programs are locked and cannot be edited, but any program can be copied, renamed, and the new program can be modified. See Fig. 4-5. All changes to non-factory programs will be stored in memory until modified or deleted. Refer to the User's Manual for detailed instructions for programming the unit.

Figure 4-5

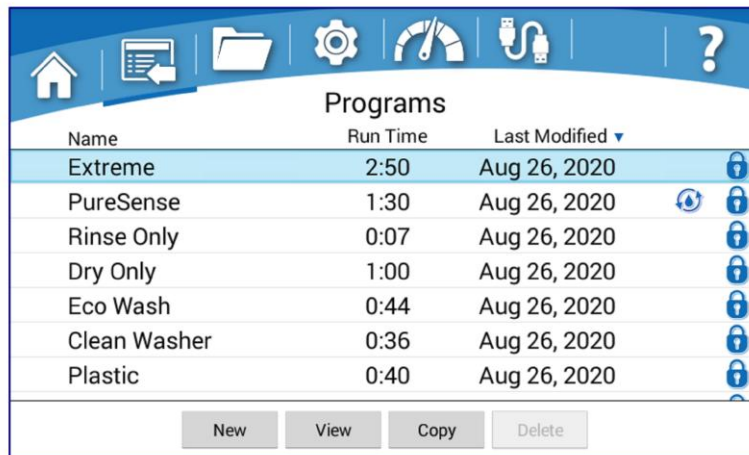

Name	Run Time	Last Modified	
Extreme	2:50	Aug 26, 2020	🔒
PureSense	1:30	Aug 26, 2020	👤 🔒
Rinse Only	0:07	Aug 26, 2020	🔒
Dry Only	1:00	Aug 26, 2020	🔒
Eco Wash	0:44	Aug 26, 2020	🔒
Clean Washer	0:36	Aug 26, 2020	🔒
Plastic	0:40	Aug 26, 2020	🔒

New View Copy Delete

Log Data

Depending on the model, the data log will collect up to 13 parameters for each program at a user-selected data rate. The Data Log Screen allows the user to sort and view up to six sets of the collected data.



Although the Data Log Screen only allows viewing of up to 6 parameters, all parameters are permanently stored with the Data Log, and will be viewable when the log file is downloaded and viewed on a computer.

A data log can be selected from the list by touching the data log file name. When a data log has been selected, the row will be highlighted as shown in Fig. 4-6. When selected, the buttons along the bottom of the screen will activate (**[View]**, **[Chart]**, **[Export]**, **[Delete]**). If a data log is currently running (collecting data), the *Running Man* icon will appear to the left of data log file name.

The screenshot shows a mobile application interface for 'Data Logging'. At the top, there is a blue header bar with several icons: a home icon, a document with an arrow, a folder, a gear, a gauge, a USB cable, and a question mark. Below the header, the title 'Data Logging' is centered. Underneath the title is a table with two columns: 'Program Name' and 'File Date'. The table contains seven rows of log files, all from 'Program 01' and dated 'Aug 03, 2020'. The second row, 'Log_2020-08-03_20', is highlighted in light blue. At the bottom of the table, there are four buttons: 'View', 'Chart', 'Export', and 'Delete'.



	Program Name	File Date
Log_2020-08-03_21	Program 01	Aug 03, 2020
Log_2020-08-03_20	Program 01	Aug 03, 2020
Log_2020-08-03_19	Program 01	Aug 03, 2020
Log_2020-08-03_18	Program 01	Aug 03, 2020
Log_2020-08-03_17	Program 01	Aug 03, 2020
Log_2020-08-03_16	Program 01	Aug 03, 2020
Log_2020-08-03_15	Program 01	Aug 03, 2020

View Data File

- From the Data Log Screen, highlight the Log to view by touching the Log name.
- Touch [\[View\]](#).
- Six columns showing data from six user-defined data points will be displayed.
- Swipe the screen up or down to scroll through the data.
- Select [\[Bottom\]](#) to snap to the bottom of the log file.
- Select [\[Top\]](#) to snap to the top of the log file.
- Select *Most Recent First* to display the newest data at the top of the log file.
- Select the *Customize* icon at the bottom right corner of the screen to change the data shown in the any of the six columns. See Fig. 4-7. Less than six data columns can be displayed; however, six is the maximum number for display.
- Select the *Information* Icons by the Alarms or Step code headers to display a table showing the code definitions.

Figure 4-7

Log_2020-08-06_6 Date: 08-06-2020 

SEGMENT	STEP 	TEMP (° C)	ALERT 	TIME REMAINING	ELAPSED TIME
Wash	Wash	50	---	0:40:00	0:10:51
Wash	Wash	50	---	0:40:00	0:10:41
Wash	Wash	51	---	0:40:00	0:10:31
Wash	Wash	51	---	0:40:00	0:10:21
Wash	Wash	51	PP	0:40:00	0:10:00
Wash	Wash	51	---	0:40:00	0:09:51
Wash	Wash	50	---	0:41:00	0:09:41

Most recent first Back Top Bottom 

Lock

Log_2020-08-06_6 Date: 08-06-2020 

SEGMENT	STEP	TEMP (° C)	ALERT	TIME REMAINING	ELAPSED TIME
Steam					0:00:01
Steam	D				0:00:11
Steam	D				0:00:21
Steam	D				0:00:31
Steam	D				0:00:41
Steam	D				0:00:51
Steam	D				0:01:01

Most recent first OK 

DATA POINT COLUMNS

Choose up to 6 columns to display.

- Segment
- Step
- Temp (° C)
- Alert
- Time Remaining
- Elapsed Time

Chart Data File

- From the Data Log Screen, highlight the Log to chart by touching the Log name.
- Touch [Chart].
- The chart will display the system temperature and/or conductivity vs time. See Fig. 4-8.
- The chart can be manipulated by zooming in and out or swiping side to side.
- If your washer is equipped with a conductivity sensor, to show or hide data on the chart, touch the drop down at the bottom of the screen and select the data to display.



The chart view will display the value of individual data points, when zooming in to a specific set of data. The values will display next to each data point when zoomed to allow 10 data points on the chart. When more than 10 data points are visible, the individual values will automatically disappear.

Figure 4-8

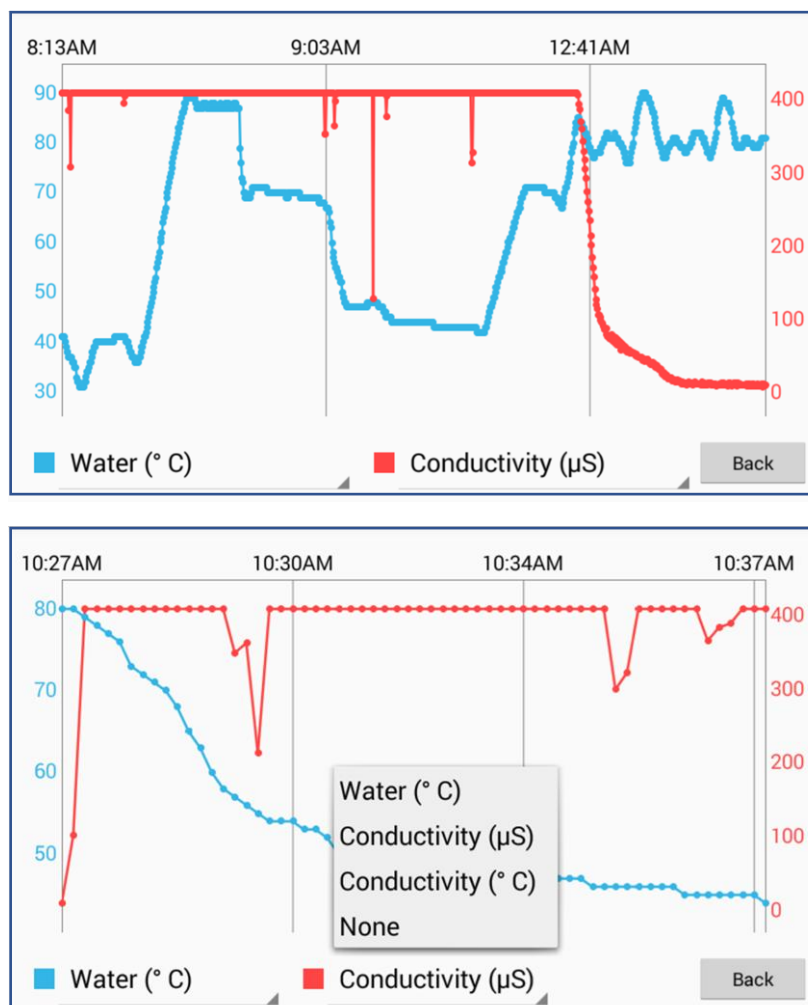

Export Data File

Exported files will include all data as shown in Fig. 4-9.

- Insert a Flash Drive into USB connection below the display and wait for recognition. Upon recognition, a pop-up will display. Touch [OK].
- From the Data Log Screen, highlight the log to export by touching the log name.
- Touch [Export].
- Select the file format (.CSV or .PDF), then touch [OK].
- Once the export is complete, the USB can be removed.



Touching and holding a file name for 3 seconds enables multiple file selection. Multiple data logs can then be selected and exported at the same time. During multiple selection mode, the option to *Select All* will be available at the top of the Data Log Screen.

Figure 4-9

Labconco Corporation Program: Intense FlaskScrubber Vantage Series Glassware Washer										
Date	Time	Elapsed Time	Time Remaining	Segment	Step	Step Code	Temp (° C)	Conductivity (uS)	Conductivity Temp (° C)	Alert
8/6/2020	7:32:02 PM	0:00:01	3:05:00	Wash	Drain	4	47	356	47	
8/6/2020	7:32:12 PM	0:00:11	3:05:00	Wash	Drain	4	47	356	47	
8/6/2020	7:32:22 PM	0:00:21	3:05:00	Wash	Drain	4	46	358	46	
8/6/2020	7:32:32 PM	0:00:31	3:05:00	Wash	Drain	4	46	357	46	
8/6/2020	7:32:42 PM	0:00:41	3:05:00	Wash	Drain	4	46	359	46	
8/6/2020	7:32:52 PM	0:00:51	3:05:00	Wash	Drain	4	46	354	46	
8/6/2020	7:33:02 PM	0:01:01	3:04:00	Wash	Drain	4	46	355	46	
8/6/2020	7:33:12 PM	0:01:11	3:04:00	Wash	Hot Fill	2	46	355	47	PP
8/6/2020	7:33:22 PM	0:01:21	3:04:00	Wash	Hot Fill	2	46	355	47	
8/6/2020	7:33:32 PM	0:01:31	3:04:00	Wash	Hot Fill	2	46		46	

Delete Data File

- From the Data Log Screen highlight the Log to delete by touching the Log name.
- Touching and holding a file name will allow you to select multiple files.
- Touch [Delete]. After deletion a pop-up will confirm number of deleted files.



Locked Log Files will not be deleted.

Settings

The Settings Screen as shown in Fig. 4-10 allows the user to set or modify the systems settings.

Figure 4-10



Language

Choose from five languages: English, Spanish, French, German, Italian.

Figure 4-11

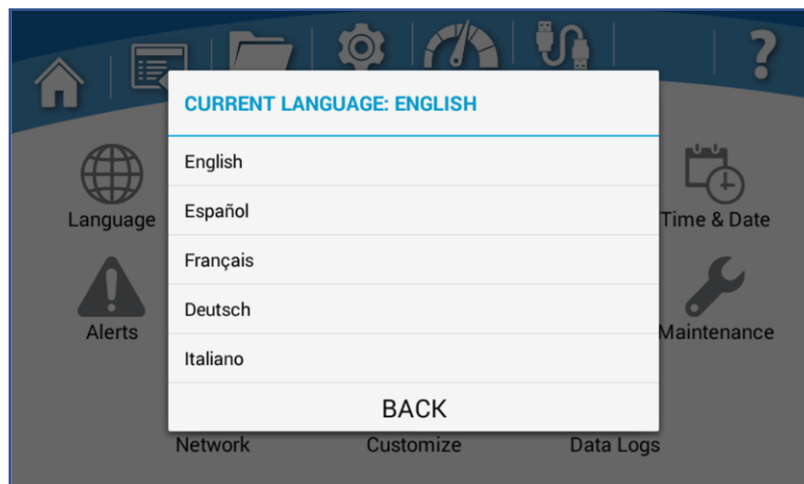

Security

A four-digit security code can be set that requires entry of a PIN to gain access to user-defined areas. The PIN will always be required to enter the Security screen.

- From the Settings Screen, touch the **Security** icon, then enter the PIN (default is 1234) to gain access.
- Select the areas to be secured. See Fig. 4-12.
- To change the PIN, touch **[Set Code]**, enter new PIN two times, then touch **[Save]**.
- Once all changes are complete, to enable security, the **Security Toggle** in the bottom, right corner of the Security Screen must be set to **Enable**.
- Touch **[Back]**.

Figure 4-12

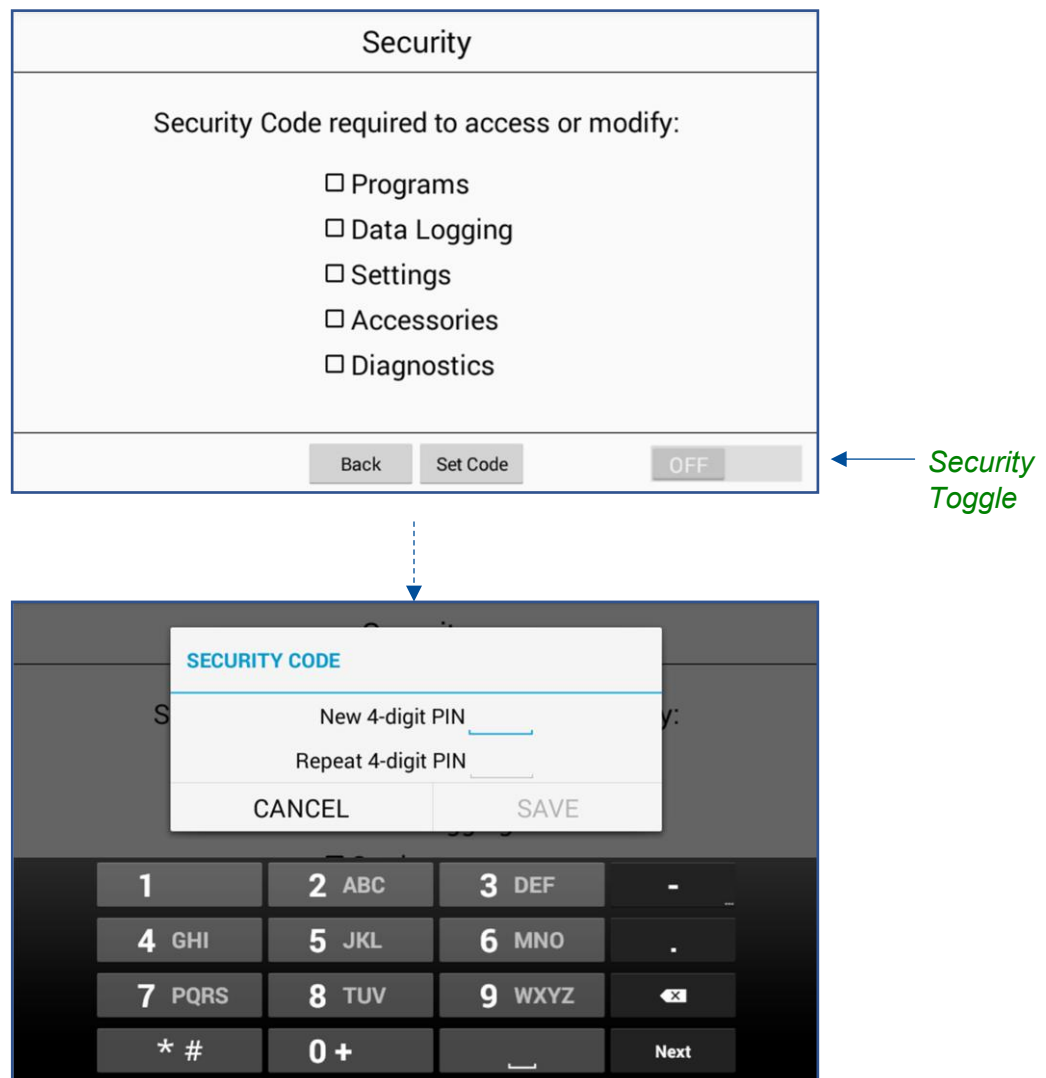

Calibration - Offsets

Adjust the sensor readings to match a known standard(s).

Current Reading (uncorrected) = raw sensor reading with no offset applied.

Offset = Value that will be added to the Current Reading (uncorrected). The adjusted reading (uncorrected + offset) is the value reported on all screens outside of the Sensor Calibration screen.

- To adjust the calibration offset, touch *Offset* field of the desired sensor. A pop-up will display, which allows an offset value to be adjusted for the sensor.
- Using a known standard as reference, change the offset to match the value reported by the standard. For example, if the *Sump / Water Temp* reports an uncorrected reading of 35 °C, and the standard reference reports 36°C, change the offset to +1°C.

Figure 4-13

Sensor Calibration			
Offsets		Setpoints	
SENSOR NAME	CURRENT READING (UNCORRECTED)	OFFSET	LAST CAL. DATE
Sump / Water Temp	21° C	0° C	Aug 24, 2020
Conductivity Temp	21° C	0° C	Aug 24, 2020
Conductivity	6 µS	0 µS	Aug 24, 2020
Fill Level	-	0 %	Aug 24, 2020
Back			



When the *Offset* value is changed, the current date will be saved as the *Last Cal. Date*

Offset limits:

- Temperature = +/- 5 °C
- Conductivity = +/- 20 µS
- Fill Level = +/- 5%

Calibration - Setpoints

Adjust the maximum program segment temperature.

Setpoint = maximum programmable temperature in any segment.

- To adjust the Setpoint, touch *Setpoint* field of the desired value. Reference Fig. 4-14. A pop-up will display, which allows the maximum set point to be set.
- The pop-up provides two choices: 88°C or 93°C.
- If the washer is installed at an elevation above 2000 meters (6561 feet), change the maximum temperature set point to 88°C. Touch [OK].

Figure 4-14

Sensor Calibration		
Offsets		Setpoints
SENSOR NAME	SETPOINT	LAST CAL. DATE
Max Water Temp Setpoint	93° C	Aug 24, 2020

Back



When the *Setpoint* value is changed, the current date will be saved as the *Last Cal. Date*

•

Time & Date

Reference Fig. 4-15. Use the Time and Date screen to choose Clock Format (12 or 24 hour), and then either manually Set the Time and Date, or enable Auto Update, which (if washer is connected to a valid Ethernet port) will auto update the time and date. With Auto Update the following settings need to be entered:

- Time Zone – Enter the Greenwich Mean Time (GMT) offset value for your location (integer value between -12 & +12).
- NTP server – Enter the “web address” (URL) of the NTP server (of your choice) that will provide clock synchronization data to the washer via the Ethernet connection. A common site is: time.nist.gov.
- Finally, Daylight Savings (ON/OFF) can be enabled/disabled for areas observing Daylight Savings Time (DST).

Figure 4-15

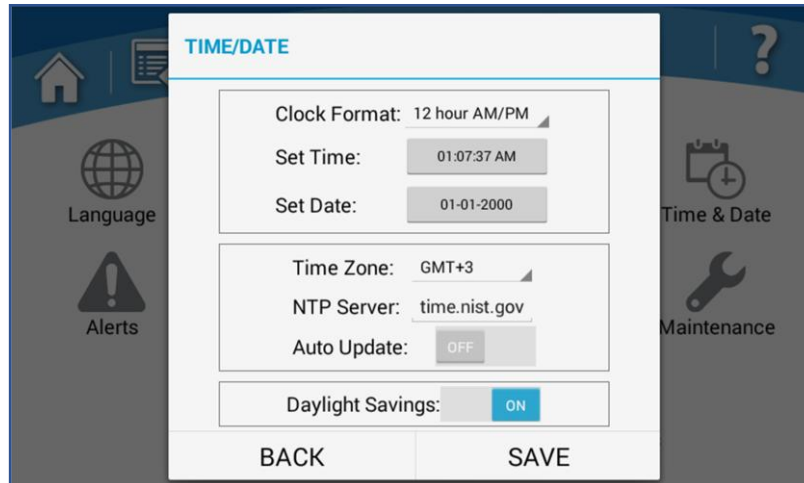

Alerts

If a valid network connection has been established via the Ethernet accessory cable, and Network settings have been properly configured, (via the Network screen) alerts can be emailed to selected users, by entering the appropriate email address(es) and selecting the type of alerts to be sent to each email address. To enable e-mail alerts, follow these instructions, and reference Fig. 4-16.

- Each washer requires its own email address. Before proceeding, set up an email address for each washer. The e-mail account can be any free service (i.e., gmail.com, hotmail.com, etc) or a company’s hosted domain (i.e., xyzlabs.com).
- Once the e-mail account(s) are set up, obtain the following information for each account (e-mail address):
 - SMTP Server
 - SMTP Username
 - SMTP Password
 - SMTP Port Number
 - Encrypted Connection

Here is an example (this information will not be correct for your e-mail account) set-up for fake e-mail account: Wash123@gmail.com

- smtp.gmail.com
- Wash123
- cat@ndmouse457
- 465
- Enable
- From the Alerts Screen, touch the *Settings* icon. A pop-up will display. After entering the appropriate information in all fields, touch **[Save]**. The system will check valid formatting only. If one or more invalid entries are found the following message will appear: *Email Settings Error*. Correct the error and retry.
- If all the SMTP fields entered are valid, but the network connection is not working (or Ethernet cable is not connected) the following message will appear *Email Settings Error – Network connection is not active*. Resolve the connectivity problem and retry.
 - To add a user's email to receive e-mail alerts from the washer:
 - Press the *Add* icon at the lower right corner to add an email address.
 - Enter your e-mail address, touch **[Done]**.
 - To test the user's email:
 - Touch **[Test]** next to the desired e-mail address.
 - If all information is correctly entered, a test email from the washer will be sent.

Once the SMTP Settings (for the washer's e-mail address) have been correctly entered, and the notification e-mail address (e-mail address for who is getting notified) has been correctly entered and tested, the final step is to select the alerts to send each e-mail address. Follow these instructions to select alerts.

- Touch **[Alerts]** next to the email address. A pop-up displays the alert options:
- Program Complete
- Status Every 15 min / 30 min / 1 hour / 2 hour
- All Alerts
- Power Fail
- Select the desired alerts. Only one Status alert frequency selection can be made. For example, if *Status Every 15 min* is selected, the other three frequency status alerts are inactive.
- Touch **[OK]**.

Figure 4-16

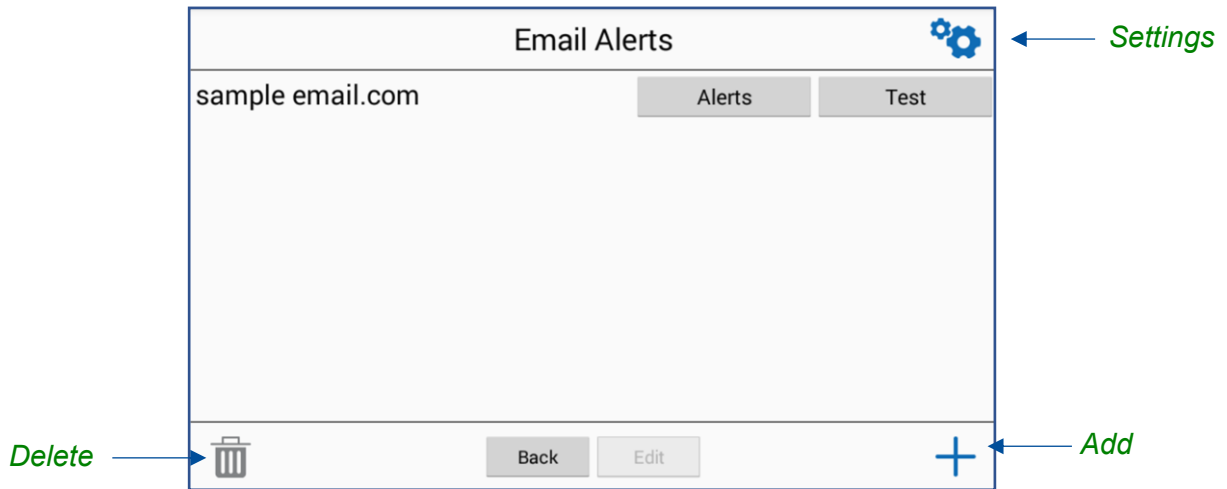

- To delete a user's email:
 - Touch the e-mail address to delete, it will highlight.
 - Touch the *Delete* icon in the bottom left corner of the screen.

Display

This screen provides settings for the display screen functionality. Reference Fig. 4-17.

Brightness Slider – Adjust the display brightness by dragging the bar left/right.

Touch Sounds – Touching the toggle between ON & OFF will enable or disable audible beeps when the screen is touched.

Screen Timeout Function – If enabled, the screen will go to sleep (low power mode) when no screen touches have been detected for the allotted time (defined in the Screen Timeout dropdown menu). Touching the Screen Timeout Function will toggle between ON & OFF.

Screen Timeout – This value can be set to 5, 10, 15, 30 min, and 1, 2, or 3 hours.

Figure 4-17

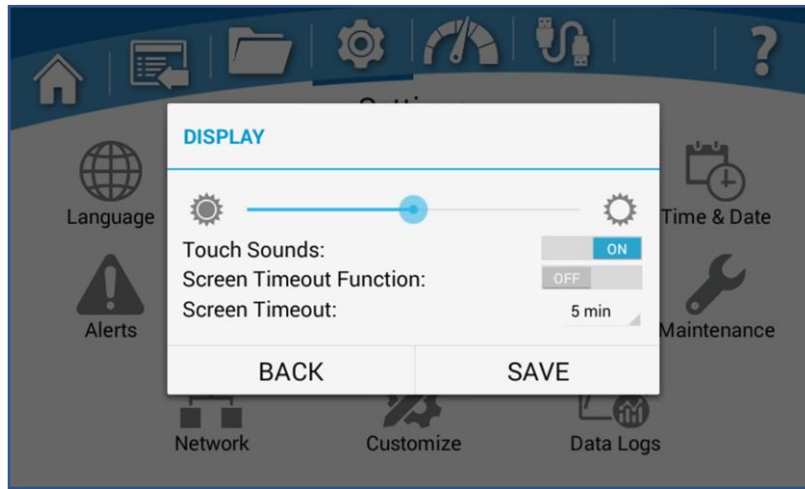

Units

This screen allows the user to change the units of measure for various sensors.

- Touch the desired drop-down field, and make selection:
 - *Temperature* – Select the desired units of measure: °C or °F
 - *Length (Depth)* – Select the desired units of measure: millimeters or inches
- Once the selection is made, touch [OK].

Figure 4-18

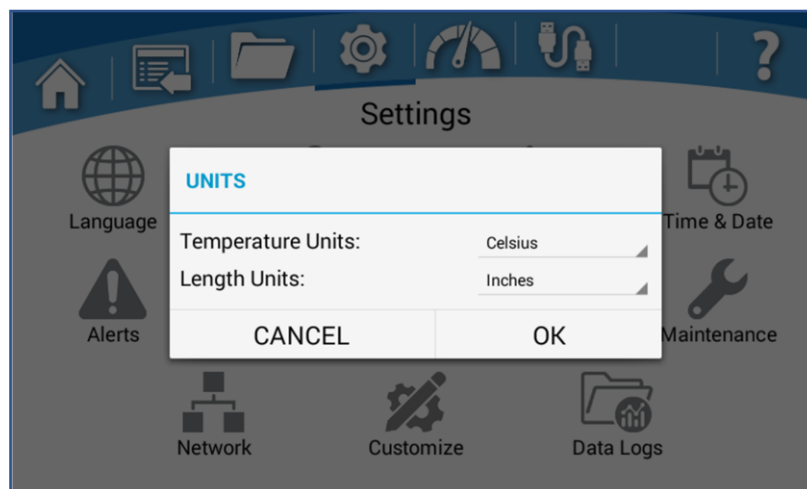

Maintenance

View the Lifetime hours for the Wash Pump and Dry Blower. Change the reminder frequency or reset the Sump Screen Cleaning interval. Reference Fig. 4-19.

- From the Settings Screen, touch the **Maintenance** Icon to view the Lifetime hours of the wash pump and dry blower.
- Touch the **Clean Sump Screen** or **Change HEPA filter** (Vantage models only) hours to modify the time interval for maintenance notifications. The default is 173 hours and 1024 hours.
- Touch **[Reset]** to reset the counts to zero (once the maintenance has been performed).

Figure 4-19

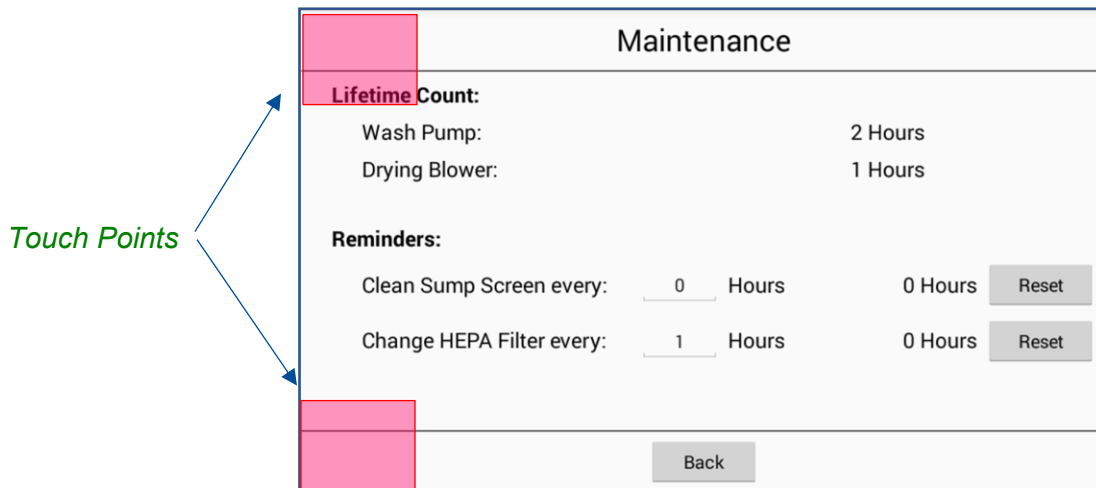

Factory Maintenance

The Factory Maintenance Screen can be accessed by touching and holding the top left and bottom left corners of the Maintenance Screen. Refer to Fig. 4-19 for the touch points. Once you have entered the Factory Maintenance screen Refer to Fig. 4-20 and the following instructions to set the water fill level, or to calibrate the Auto dispense pumps if equipped. A Factory Reset and the total lifetime hours can be reset from this screen.

Figure 4-20

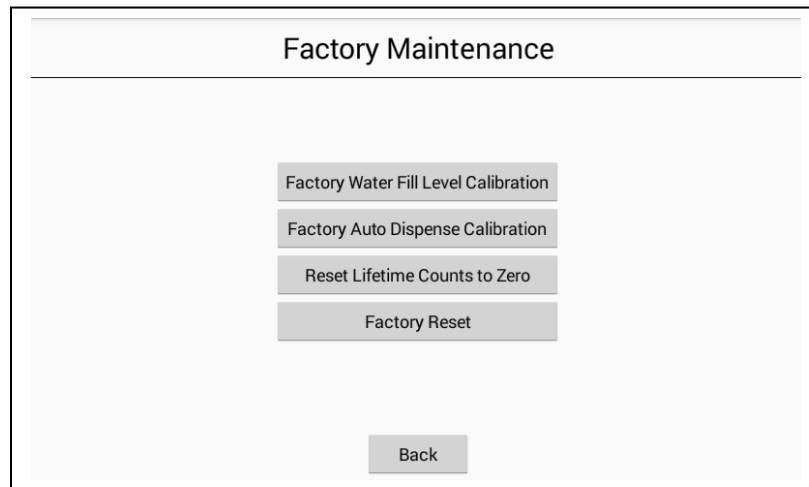

Factory Water Fill Level Calibration and Water Level Pressure Switch Test

Use this screen to calibrate the water level sensor to the proper set point by selecting **[Fill to Current Set Point]**. Water will enter the wash tank until the current set point is reached. When full, the water level should just be touching the bottom of the heating element. The water level can be adjusted by adding or subtracting 1 to 5 units of water. Once the water level is set to the proper height save the setting by pressing **[Save]**. The new set point is now saved.

If you wish to test the Water Level Pressure Sensor set point continue to page 114. If you have a washer manufactured before August 2023, catalog rev J, see the instructions below or select **[Back]** to exit the screen and **[Yes]** to drain the tank.

Set Overfill Sensor:

1. Turn the power back on
2. Go to the Maintenance Screen, and touch for 2 to 5 seconds the top and bottom left corners of the display simultaneously to get to the Factory Settings page.
3. Perform a factory fill. Once completed change the fill time to 5 and continue to fill the tank. Continue filling the tank. You will receive the High Water Alarm. Keep filling until the water level touches the baffle retainer on the front of the washer. Turn off the water immediately by pressing the "OK" and "STOP FILL" buttons on the display.
4. Check the water level in the tank. The water level should be just touching the baffle retainer. The blue light on the overfill sensor should be on.

- a. If the water level didn't reach the baffle retainer, the sensor should be moved up. Add water until it reaches the baffle retainer and the blue light turns on.
 - b. If the blue light is not on, the sensor should be moved down.
5. Raise the sensor up 1/8" above this until the light goes off. Tighten the screw (do not overtighten).
6. Drain the water and repeat step 4 to confirm that the Overfill Sensor is set correctly. **Caution:** *In the Factory Fill Screen only, you can continue to add water over the High Water Alarm until the Overfill Sensor actuates. If the Overfill Sensor is set too low, you will never get the High Water Alarm. If the Overfill Sensor is set too high and never actuates you can continue to add water and over run the tank.*

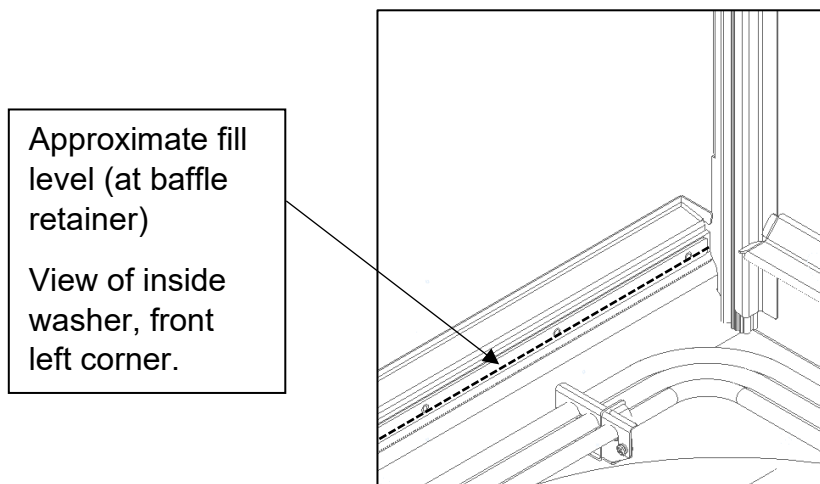

Washers manufactured before August 2023, catalog rev J - Once the Water Level Pressure Switch set point has been saved, this screen can be used to test the set point of the Water Level Pressure Switch by continuing to add more water to the washer. Continue to slowly add units of water until the water level pressure switch actuates and turns power to the inlet valve off. You can monitor the switch actuation by using a voltmeter. With the meter set to DC volts, connect the leads across the two terminals of the switch while it is still plugged in. Refer to figure 8-11 for the pressure switch location. When the switch actuates, the meter will read approximately 5.7VDC. If a voltmeter is not available, you will know the switch has actuated if you add water and the display is indicating water is being added but no water is entering the tank. You may get a High-Water Alarm as you are performing this test which is normal and can be dismissed. Continue to monitor and add water until the switch actuates or before water overflows the bottom opening of the wash tank. When the switch actuates the water level should

be between the top of the rectangular distribution tube (Refer to figure 5-2) and the bottom opening of the wash tank.

If the trip point is incorrect the switch set point can be adjusted higher by turning the adjustment screw counterclockwise or lower by turning the screw clockwise. Note: the adjustment screw is very sensitive so use caution and go slowly when adjusting. Refer to Figure 8-11.

If the trip point is too low, (below the top of the distribution tube) with the voltmeter connected, slowly turn the adjustment screw counterclockwise until you get no VDC reading. Add more water until the switch actuates again. Repeat this process until the proper set point is reached. Drain the tank completely and retest to confirm the set point is correct. Repeat test and adjustment as required.

If the trip point is too high, (water running out of the tank) drain water from the tank to a level above the top of the distribution tube and just below the lower tank opening. With the voltmeter connected, slowly turn the adjustment screw clockwise until you get 5.7VDC reading. Drain the tank completely and retest to confirm the set point is correct. Repeat test and adjustment as required.

Once the set point is correct drain the washer.

Note: Do not press save unless the water level is at the correct normal level (just touching the bottom of the heating elements).

Factory Auto Dispense Calibration

Use this screen to prime and calibrate the Auto Detergent or Rinse Aid dispense systems. Refer to Figure 4-20. You will need a way to measure the amount of liquid being dispensed, like a 100 ml graduated cylinder large enough for the suction lance to fit down into. Place the suction lance of the dispense system you wish to calibrate into the graduated cylinder with an enough liquid to fill the cylinder.

- Select [Detergent1] or [Rinse1].
- Select [Prime] The selected system's pump will run for 30 seconds to prime the system tubing.
- Refill the Graduated Cylinder if needed.
- Note the amount of liquid in the graduated cylinder.
- Select the amount of liquid you wish to dispense less than the amount in the cylinder and select [Dispense]. The pump will run, drawing liquid from the cylinder.
- Once the pump stops, determine the amount of liquid that was dispensed and enter that amount on the display, select [Save].

- The selected pump should now be calibrated.
- Repeat procedure for the other pump if needed.

Reset Lifetime Counts to Zero

Use this screen to reset the total lifetime hours count for the wash pump and dry blower to zero if they have been replaced. Refer to Figure 4-20.

Factory Reset

Use this screen to reset all programs and settings to the original factory settings. Refer to Figure 4-20.



If a FACTORY RESET is performed, all user programs will be erased, and the factory settings will be reinstated. User defined programs should be exported and saved before performing a Factory Reset. Refer to [Backup and Restore](#) on the [Help](#) page for instructions.

Network

Modify Network connection specifications, if an active ethernet connection has been established.

The most common setting for network connectivity via an Ethernet port is DHCP Enabled. This setting allows the facility's network to dynamically assign an IP address. Reference Fig. 6-23. Touch the toggle next to *DHCP Enabled* to change between enable / disable. When enabled, the remaining fields will be grayed out, as these will be assigned by the facility's network. If the field next to *IP Address* is populated with four sets of numbers (each separated by a period), and a green "Active connection detected" is displayed the washer has successfully received an IP address from the network. A red "No active connection detected" will be displayed if no connection is found. Please consult your IT department for additional assistance.

If a static IP address must be assigned by your facility's IT department, set the *DHCP Enabled* toggle to Disable. Contact your IT department for the appropriate information to enter the remaining fields.

Figure 6-23

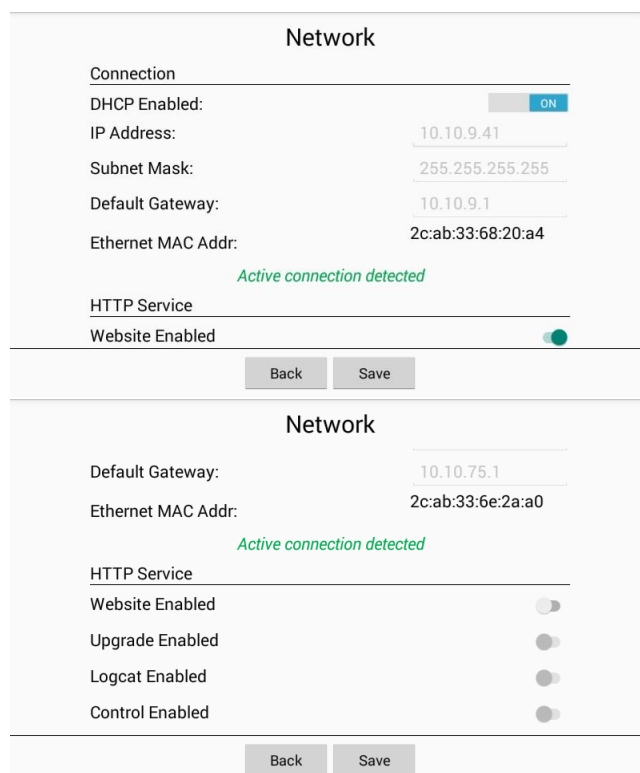

By enabling 'Website Enabled', you will be able to remotely connect to the Washer. You will also be able to download data logs by selecting the one you want.

Once website access is enabled, to use these features, you must log onto the same network as the Glassware Washer. On your device, enter the web address shown in the IP address above. The IP address must be preceded by 'http://'. For example: `http://ipaddress`.

If you enable 'Upgrade Enabled', you will be able to upgrade the Washer using the Labconco website(see Software Update via Ethernet).

If 'Logcats Enabled' is selected, you can download the logcats. Once on the webpage the following screen will appear. Select 'Logcat' on the screen below and the file will download. This is a troubleshooting file used by Labconco service personnel to

diagnose issues.

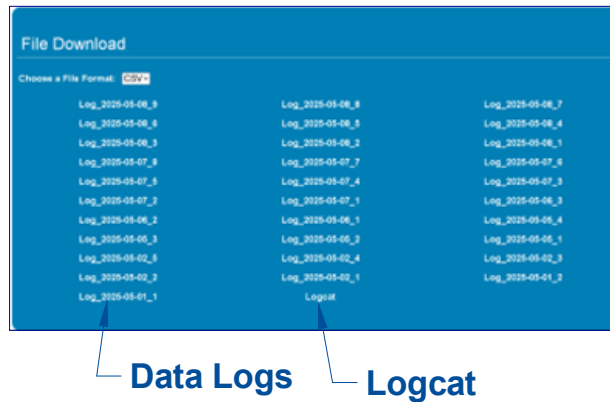

If 'Control Enabled' is enabled, you will be able to have limited control remotely from a computer or other device. From your device, you will not be able to enter alphanumeric values. You will be able to select buttons and the spinners. If security is turned on, you won't be able to use this feature. You will see the same screen as what is on the Washer.

Customize

This screen allows the user to customize the washer's name. The name is utilized on all Data Logs, and on any e-mail Alerts (if enabled and connected via Ethernet cable).

If the optional Auto Detergent and/or Rinse Aid Dispense kit(s) are installed, use the Customize Screen to customize the Auto Detergent and Rinse Aid names and abbreviations shown in the Program Screens. In addition, the maximum allowable dispense volumes of the Auto Detergent and Rinse Aid can be modified.

- From the Settings Screen, touch the *Customize* Icon.
- To change the washer's name, touch the field next to *Device Name*, and change the name as desired (18 characters maximum). Touch **[OK]**.

If the Auto Detergent and/or Rinse Aid accessories are installed:

- To change the auto detergent or rinse aid name, touch the respective name field in the *Custom* column. Modify the name as desired (12 character maximum). Touch **[OK]**.
- To change the auto detergent or rinse aid abbreviation, touch the respective name field in the *Abbr.* column. Modify the abbreviation as desired (2 character maximum). Touch **[OK]**.



The auto detergent and rinse aid abbreviations are utilized in the Program Wizard to select the auto detergent or rinse aid source.



The auto detergent and rinse aid name fields are utilized when displaying the respective accessory on the *Sensors* and *Accessories* Screens. And, on the Summary with Detail printed receipt to identify which detergent/rinse aid was dispensed (if the optional printer accessory is installed).

- In the Program Wizard the auto detergent and rinse-aid dispense volumes are selectable in 1 mL increments up to a maximum of 40 mL. To adjust this maximum allowable value, touch the respective field in the *Max Disp.* column.
 - A pop-up will appear. Swipe up/down to adjust the max allowable dispense volume in 1 mL increments. The limits to this adjustment are:
 - Auto Detergent: 100 mL
 - Rinse Aid: 100 mL
 - Once all changes are complete. Touch **[Save]**.
- The Customize Screen is shown for reference in Fig. 4-22.

Figure 4-22

Device Name: <u>Labconco Washer</u> 15/18			
Auto Dispense Names			
ADDITIVE	CUSTOM	ABBR.	MAX DISP.
Detergent 1	Detergent 1	D1	40 mL
Rinse Aid 1	Rinse Aid 1	R1	40 mL
<input type="button" value="Back"/> <input type="button" value="Save"/>			

Data Logs

Modify the Data Acquisition Rate and the Log File Deletion settings.



- Touch the drop-down menu next to *Data Acquisition Rate* and modify the rate among the intervals available: 10sec, 30sec, 1min, 5min or 10min. Touch **[OK]**.
- Touch the drop-down menu next to *Log File Deletion* and modify the deletion interval among the selections available: 1 week, 1 month, 3 months, 6 months, 1 year, Never. Touch **[OK]**. Refer to Figure 4-23.

- The system default for Log File Deletion is Never.

Figure 4-23

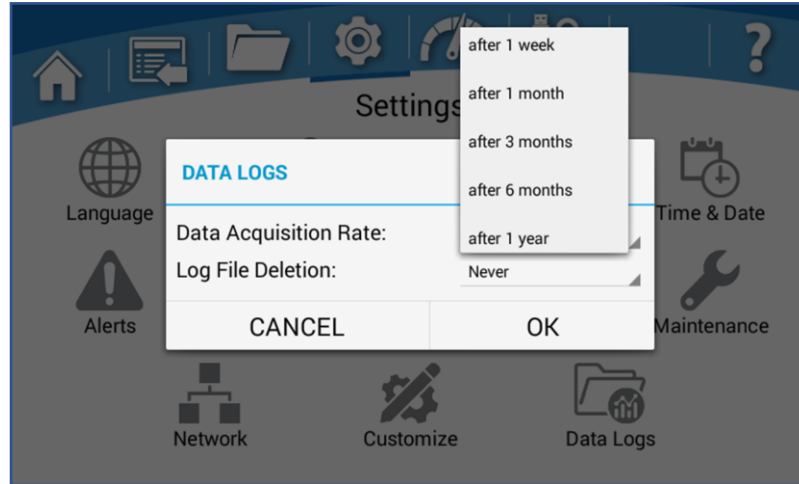

Sensors

This screen contains a list of all the sensors currently installed on the Glassware Washer. The Sensors Screen displays the current sensor reading (including offsets) in the selected unit of measure. This screen is for viewing only (there are no selectable fields). Reference Fig. 4-24.

Figure 4-24

Sensors	
NAME	VALUE
Sump / Water Temp	24° C
Conductivity Temp	29° C
Conductivity	3 µS
Fill Level	0.00 mm
Detergent 1	-
Rinse Aid 1	-
Overflow	-
Door	-

Accessories

This screen contains the list of all accessories currently installed on the Glassware Washer. The screen displays the state (Enabled/Disabled) of each accessory. The Status can be switched ON or OFF to Enable or Disable the accessory. Accessories can be turned off, for instance if the washer is not connected to pure water, the Pure Water can be disabled. If the pure water connection is pressurized the Pure Water Pump is not required and can be turned off. Reference Fig. 4-25.

If equipped, the following accessories may be displayed and enabled/disabled from the Accessories Screen:

- Pure (DI) Water Pump
- Pure (DI) Water
- Detergent 1
- Rinse Aid 1
- Conductivity
- LED Light

To enable/disable an accessory, touch the toggle to change between ON/OFF. See Fig. 4-25.

Figure 4-25

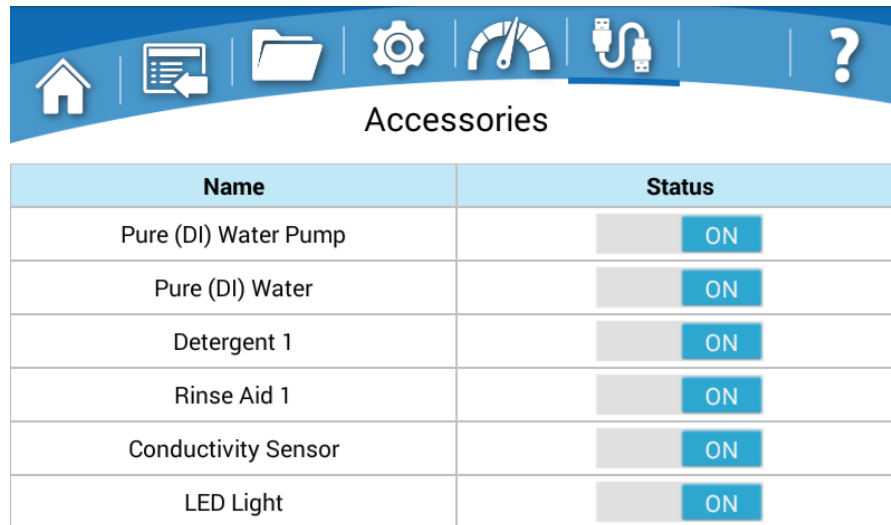

Name	Status
Pure (DI) Water Pump	ON
Pure (DI) Water	ON
Detergent 1	ON
Rinse Aid 1	ON
Conductivity Sensor	ON
LED Light	ON

Help

The Help screen contains several useful submenu icons. The sub-menus are described briefly below. Reference Fig. 4-26.

About Screen – Provides unit specific information (Catalog Number, Serial Number, Software Version). Software updates via USB and Ethernet can be performed from the About page.

Diagnostics – Used to test washer operation/components after installation or should a problem occur.

Resources – Provides QR codes for direct links to the Labconco Website for documentation or accessory/consumable information.

Backup/Restore – Allows the user to export custom programs and/or data logs, as well as import custom programs.

Figure 4-26

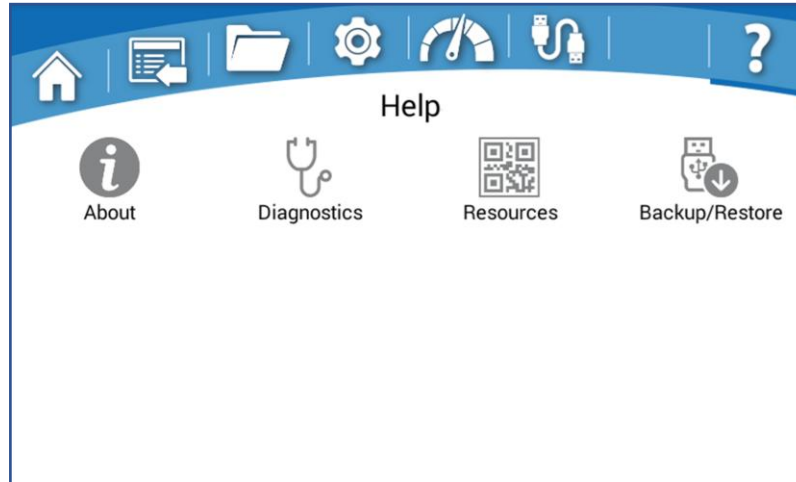

About

Displays Operating System information such as the software version, the Catalog Number and Serial Number. System updates via USB can be performed from the About screen. Reference Fig. 4-27.

Figure 4-27

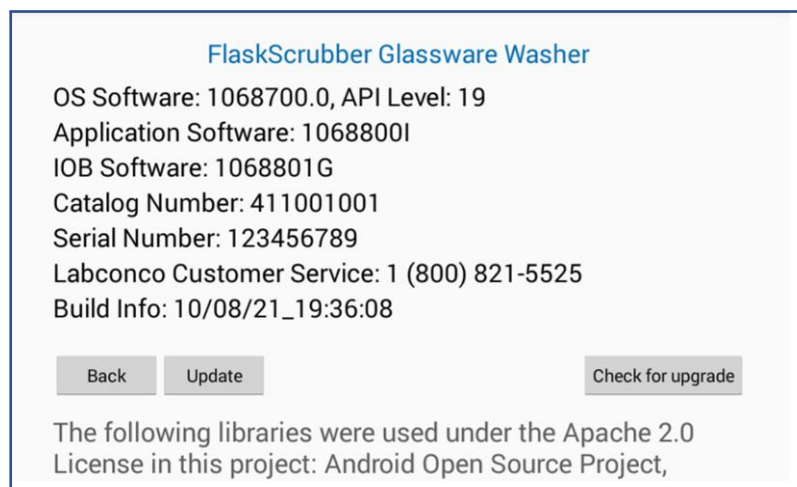

Software Update via USB Thumb drive

To update the software via USB, you must first download the latest version to a USB thumb drive, The software is available at Labconco.com. [Software & Apps - Labconco](#).

- From the About screen, touch [\[Update\]](#).
- Insert the flash drive into the USB port located under the display screen.
- Once the system recognizes the flash drive, touch [\[OK\]](#). Select the new file to load. The file name will be similar to WA_BND_XX_vJ.LCC with the J position representing the revision letter.
- The software will automatically copy the software bundle, unpack it, and install the software update. The system will notify you when the upload is complete and successful.
- Remove the thumb drive from the USB port.

Software Update via Ethernet (Push)

Once you have an active Ethernet connection you can update the software via this connection. Once the connection is established and Ethernet software updates is enabled, determine the IP address of the washer which can be found on the Settings/Network page. From your computer type in the IP address, this will take you to the Washer's Product Information Page.

- Go to the Product Support Tab found at the top of the page.
- At the Labconco Website go to Resources/Software and App page to download the latest CleanWorks software Zip file.
- Download and unzip the file.
- Return the Washers Product information page.
- Select the Update Software Tab.
- Choose the file just saved with the following format. (WA_BND_XX_vH.LCC)
- Select upload.
- The software will automatically copy the software bundle, unpack it, and install the software update. The system will notify you when the upload is complete and successful.

Software Update via the Ethernet (Pull)

To update the software via the ethernet, you must first have an active connection.

- From the [About](#) screen, touch [\[Check for Upgrades\]](#).
- If a new update is available the [Upgrade Available](#) screen will display and allow you to ignore, postpone or update now. Refer to Figure 4-28
- Pressing the [Release Notes](#) will allow you to review the changes.
- If a new update is available and you would like to update, select [\[Update Now\]](#).

Figure 4-28

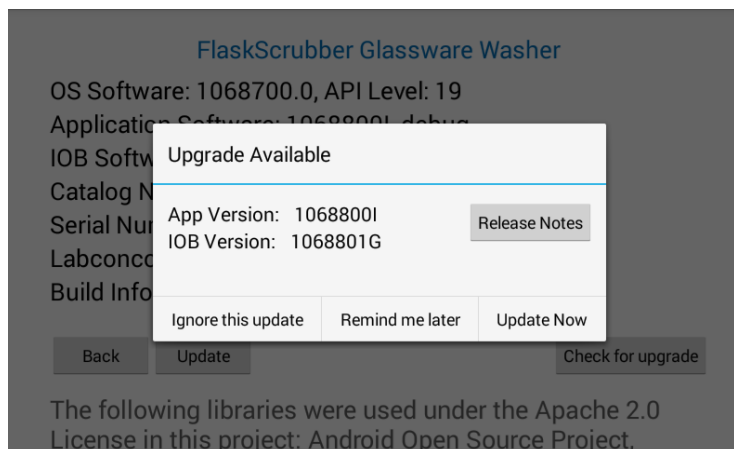

Automatic Update Notification

To Program the washer to notify you if Upgrades are available, the system must have a valid ethernet connection and the latest software installed.

- From the **About** screen, touch **[Check for Upgrades]**.
- At the **Upgrade** screen touch **[Configure]** and select **Automatically check for updates** and **[OK]**.

Once programmed the Upgrade Available screen will pop up when new software becomes available. Updates will not load automatically and must be confirmed by the user.

Diagnostics

The Diagnostics Screen is used to test washer operation/components after installation or should a problem occur. Each electrical component can be turned on individually, or single operation can be tested, such as Fill or Drain. Reference Fig. 4-29.

- FILL ALL THE WAY: Fills to the set point level via the hot water supply
- FILL ALL THE WAY PURE: Fills to the set point level via the Pure water supply
- DRAIN ALL THE WAY: Drains washer for 3 minutes (drain valve & drain pump)
- WASH PUMP: Operates the Wash Pump for 10 seconds
- HEATER 1: Operates Heater 1 for 10 seconds
- HEATER 2&3: Operates Heaters 2&3 for 10 seconds (3 Phase units only)
- DRAIN VALVE: Operates Drain Valve for 10 seconds
- DRAIN PUMP: Operates Drain Pump for 10 seconds
- PRINTER TEST: Test Printer function (if installed).

- Manual/Auto Run Tests: Automatically runs a diagnostic and checks amperage draw on all low voltage components below. There will be a 10 second delay before each DC test begins and should be allowed to complete to get an accurate current reading.
 - FILL VALVE (HOT TAP): Operates Hot Water Fill Valve for 10 seconds
 - DI VALVE (PURE): Operates Pure Water Fill Valve for 10 seconds
 - DI PUMP (PURE): Operates Pure Water Pump for 10 seconds
 - DETERGENT CUP: Operates the Detergent Cup (recommend closing Cup before running – after test the Door Detergent Cup should be open)
 - DRY BLOWER 1: Operates Dry Blower for 10 seconds
 - ELECTRONICS COOLING FAN: Operates Fan for 10 seconds
 - LED LIGHT: Operates Door Window Light for 10 seconds
 - DETERGENT PUMP 1: Operates Auto Detergent dispense pump for 30 seconds
 - RINSE AID PUMP 1: Operates Auto Rinse Aid dispense pump for 30 seconds
 - DOOR LATCH: Opens the Door Latch

Figure 4-29

Diagnostics	
WASHER COMPONENT	TEST RESULT
Manual Only Run Tests	
▶ FILL ALL-THE-WAY	
▶ DRAIN ALL-THE-WAY	
▶ SERVICE CYCLE	
▶ Manual/Auto Run Tests	
▶ FILL VALVE (HOT TAP)	
<input type="button" value="Back"/> <input type="button" value="Export USB"/>	

Resources

The Resources Screen provides QR codes for a direct link to the Labconco website for documentation and/or accessory and consumable information. Reference Fig. 4-30.

- From the Help Screen, touch **Resources**.
- Using a smartphone with camera, scan the desired QR code and you will be directed to the appropriate information on labconco.com.

Figure 4-30



Backup and Restore

Allows for the import/export of custom programs and/or data logs via USB thumb drive. Either export user-created programs and/or data log files or import user-created programs from another washer. Reference Fig. 4-31.

- Insert thumb drive in the USB port below display.
- Once system recognizes the USB thumb drive, touch [OK].
- From the Help Screen, touch *Backup/Restore*.
- Select an action: *Export* or *Import*.
 - If Export selected, choose to export either *Log Files* or *User Programs*, or both can be selected.
- Touch [OK].
- If exporting, a progress pop-up will display, and notification provided when export is complete.
- If importing, a progress pop-up will display, and notification provided when import is complete.
 - If the thumb drive in the USB port does not contain a proper User Program backup file, an error message will be displayed.

Figure 4-31

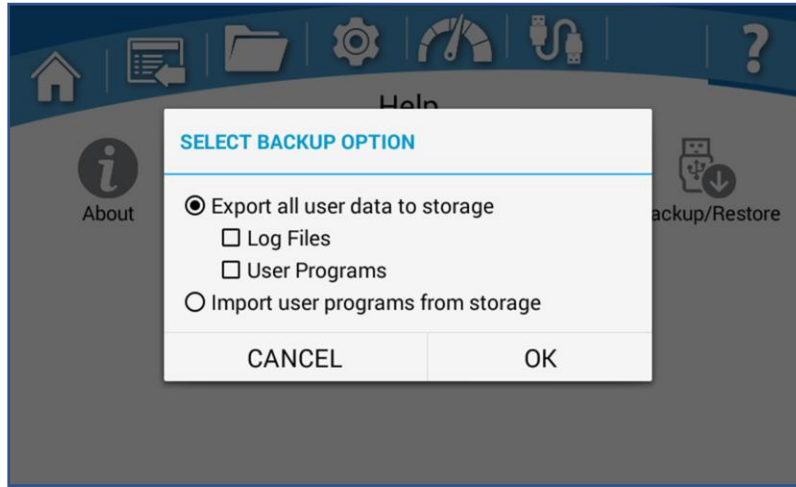

Notification

The Notification Screen allows the user to see all alerts that were encountered. The alerts can be exported as CSV or PDF file format with a thumb drive.

Notification History	
Description	Recent Top ▼
Program Canceled	May 15, 2025 12:32 PM
Program Canceled	May 15, 2025 12:04 PM
Low Temp Wash/Rinse	May 15, 2025 12:03 PM
Door Open	May 15, 2025 10:00 AM
Door Open	May 15, 2025 09:59 AM
Door Open	May 15, 2025 09:59 AM
Door Open	May 15, 2025 09:29 AM
Door Open	May 14, 2025 01:52 PM

Back Export USB

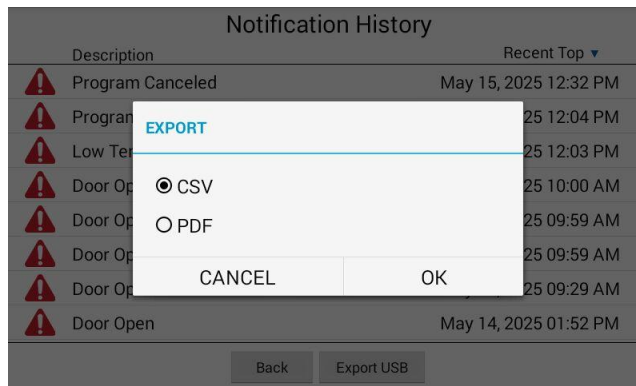

5: Maintenance

Like any piece of laboratory equipment, the glassware washer requires some routine maintenance. This section contains instructions on how to perform upkeep and routine maintenance on your glassware washer.

Maintenance Safety Precautions



The following safety precautions must be followed by all personnel maintaining the equipment.

- Wear safety glasses, and/or additional eye and face protection as required by your Health & Safety Department.
- Wear gloves, and/or additional skin protection as required by safety instructions for cleaning/disinfecting chemicals used. Consult your Health & Safety Department for additional skin protection requirements.
- No loose-fitting clothes.
- Wear close-toed shoes.
- Although the service operations detailed in this section do not involve access to areas of the product with moving or electrical parts, should you remove any panels that expose moving or electrical parts, you must follow these instructions before doing so:
 - Disconnect main power cord or electrical service connection.
 - Never touch moving parts such as fan blades or blower wheels.



Recommended Maintenance Schedule

Perform the maintenance operations described in this section in accordance with the frequency recommendations in Table 5-1. Failure to perform these maintenance operations may impair the performance of the Glassware Washer.

Table 5-1

Maintenance Frequency			
Activity	Weekly	Monthly	Annually
Wipe down interior and exterior surfaces of the stainless-steel door and wrapper	•		
Run the Clean Washer Program		•	
Check and clean the Sump Filter Screen		•	
Check and clean the inlet valve filter screen(s)			•
Check and clean the drain Air Gap			•
Replace HEPA Filter (if equipped)			•
Clean Conductivity Sensor (if equipped)			•

Maintaining the Stainless-Steel Surfaces

The interior and exterior of the Glassware Washer is type 304 stainless steel. Never use strong acids or metal scouring pads on the stainless-steel surfaces. Strong acids can corrode, and metal scouring pads can scratch or leave ferrous particulates that will rust. To maintain the appearance and quality of the stainless-steel, perform the following tasks as needed:

- Wipe the outer edges on the inside door panel to remove particles and residue that occur during loading.
- Use a sponge and non-abrasive stainless-steel cleaner to gently wipe the washer tank and door to remove surface discoloration caused by exposure to halogenated compounds or steel parts. In some cases, the finish may be slightly dulled by this action.

Clean Washer Cycle

If your water has a high mineral content, film or spots may develop on the washer interior. If the procedures listed above do not eliminate the film or spots, you may run your washer through the Clean Washer Cycle below.

- Remove all glassware from the washer.
- Pour one to two cups of 4-8% acetic acid or white vinegar into the bottom of the washer tank.
- Select and run the Clean Washer Program.
- Repeat cycle as required.

Maintaining the Air Gap in Drain

If the installation included an air gap (recommended) it requires periodic cleaning. The air gap is not part of the washer; therefore, it is not covered by the washer warranty. The air gap protects against water backing up into the glassware washer in the event of a clogged drain. Check the air gap for build-up any time your washer is not draining well.

Most types of air gaps are easy to clean. Simply follow the manufacturer's directions for maintaining the air gap.

Maintaining the Water Fill Valve

The water fill valves on the washer include a filter screen to remove dirt/particulate in the supply water lines. The filter screens may require periodic cleaning to remove trapped particles. A low water condition or Fill Fail Alarm may occur if the blockage is not removed. See Fig. 5-1 and follow these steps to clean the inlet valve filter screen.

- Turn off the water and disconnect electrical power to the washer.
- Gain access to the rear of the washer. If the washer is a Freestanding model, remove the rear panel.

- Turn off and disconnect the water supply line that is connected to the valve to be cleaned.
- Remove the valve filter screen and clean it thoroughly under running water.
- Replace the screen and reassemble the valve connection. Verify the O-ring gasket is positioned in the groove in the fill valve body.
- Turn the water supply back on.

Figure 5-1

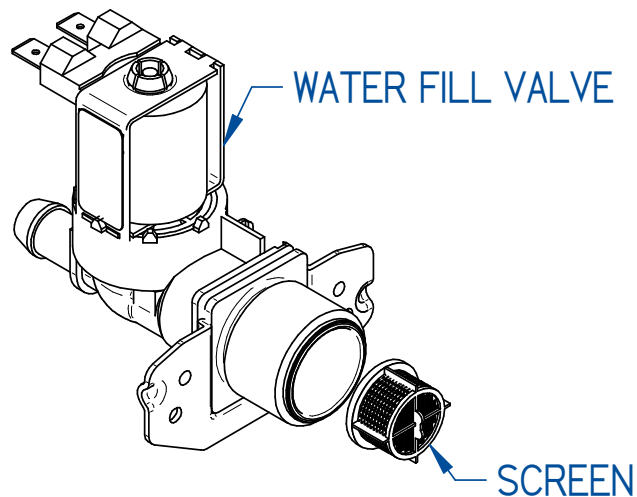

Cleaning the Sump and Sump Filter Screen

If debris accumulates on the filter screen, which is in the washer sump, the performance of the washer may be affected. The sump filter screen must be removed and cleaned periodically. The washer is programmed with a default reminder to clean the sump every 173 hours of operation. This reminder can be turned off by setting the reminder hours to zero. The interval can be changed if desired. Go to the Settings Screen, then select *Maintenance* to reset or change the reminders timer. See Fig. 5-2 and follow these instructions to clean the filter screen.

- Open the washer door and remove the lower rack.
- If the optional Heater Cover is installed, remove it.
- Remove the thumb screw that retains the filter screen.
- Carefully lift the screen and pull outward, using care not to drop debris into the sump.
- Clean the screen using a mild detergent and clean water.

- While the screen is removed check for and remove any debris in the bottom of the sump.
- When replacing the screen make sure the two tabs on the bottom of each side of the distribution tube slide under the metal plate in the back of the sump and the screen is seated in the sump emboss of the tank floor.
- Re-secure the screen to the sump with the thumb screw.
- Reset the Clean Sump Screen Reminder as described in Chapter 4 Maintenance Screen.

Figure 5-2

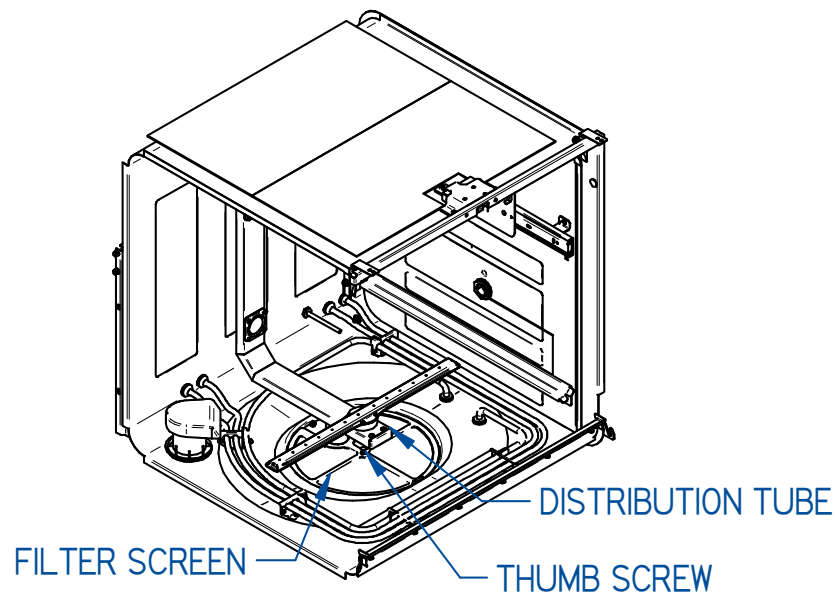

Replacing the HEPA Filter (PN4597300) (FlaskScrubber Vantage only)

After an extended period, dirt and debris may block the air flow through the HEPA filter. The HEPA filter is available from Labconco (Catalog Number 4597300). See Fig. 5-3 and follow these instructions to replace the HEPA filter.

- Open the left door by pressing in and releasing the right side.
- Press down on the lock tab on the top of the HEPA filter and pull the top of the filter outwards.
- Lift the filter out of the bottom retainer.

- Replace the filter by first placing the bottom of the new filter in the bottom retainer and then pressing down on the locking tab.

Figure 5-3

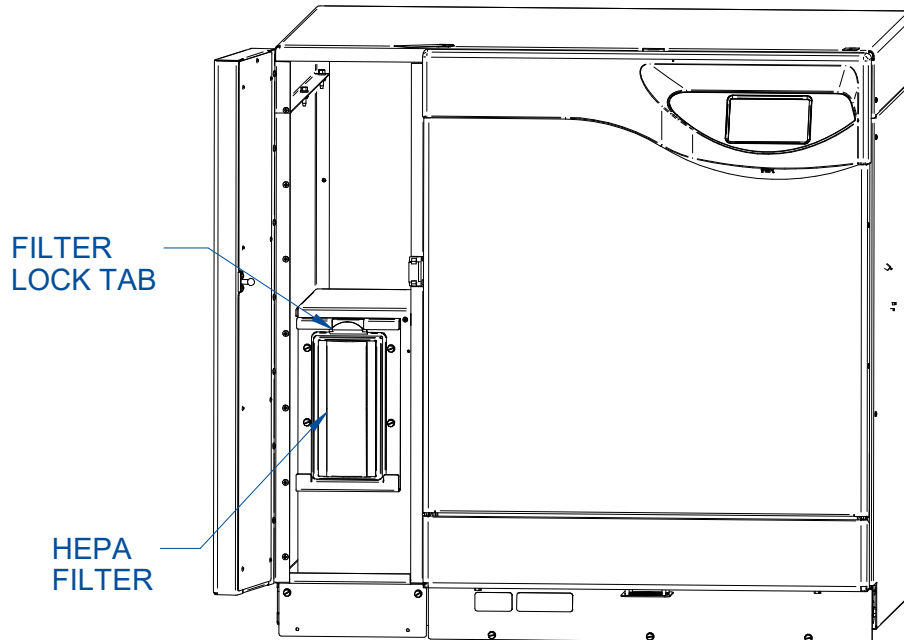

- Reset the Replace HEPA Filter Reminder as described in Chapter 4 Maintenance Screen.

Maintaining the Conductivity Sensor (FlaskScrubber Vantage only)

The operation of the Conductivity Sensor may degrade if it becomes contaminated with soil from glassware that has not been rinsed prior to being placed into the washer or if it becomes coated with minerals from the water supplied to the washer. If cleaning the sensor fails to correct the problem, the sensor should be replaced. If the interior of the washer is discolored and appears to be coated with a film, there is a good possibility that the conductivity sensor is also coated. Follow the directions for removing film or spots from the washer interior described previously in this section.

Cleaning the Conductivity Sensor

If the soil from un-rinsed glassware or hard water deposits has coated the sensor, the sensor may be cleaned using a solvent compatible with the soil. Remove the sump filter screw as described previously in this section. Using a swab moistened with solvent, remove the soil from metal parts inside the tubular portion. See Fig. 5-4.

Figure 5-4

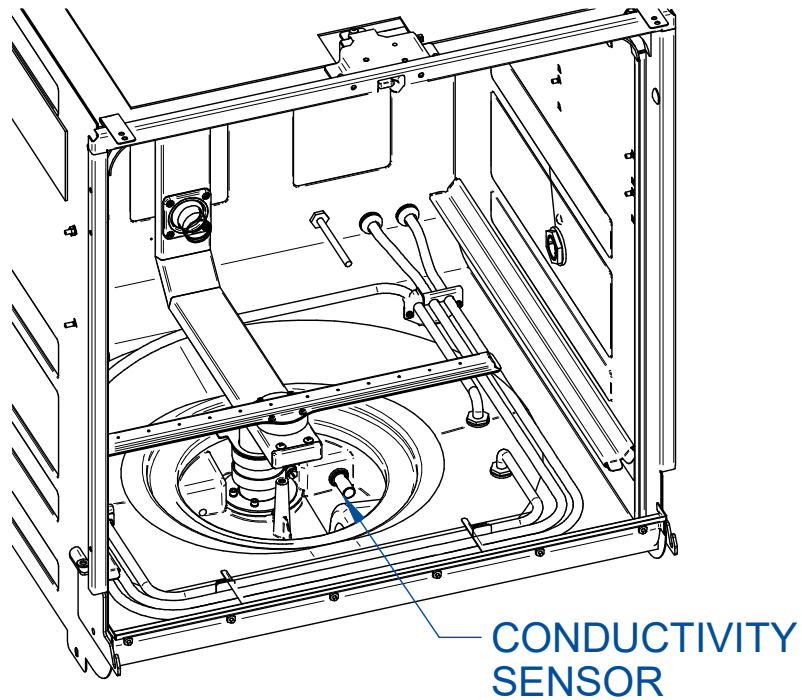

6: Modifications

This section details the installation of accessories, the functional features, and proper techniques for safely and efficiently using the Glassware Washer.

Washer Rack Configuration

The FlaskScrubber Glassware Washer is equipped with the lower spindle rack while the SteamScrubber comes with lower and upper standard racks. In addition to the standard rack configuration of each model, many optional racks and inserts are available to customize your washer to best suit your needs. For a complete list of available rack accessories, refer to [Section 9: Accessories & Consumables](#).

If equipped, the upper racks are easily raised or lowered to accommodate different size glassware. The optional upper rack may also be removed from the Glassware Washer to facilitate loading the rack outside the washer or to allow very tall glassware to be loaded and washed on the lower rack. See Fig. 6-1.

Installing the upper rack slides

- Remove the acorn nuts and lock washers from both upper sides using a 3/8" wrench. There are 4 on each side.
- Secure the slide assemblies using lock washers and acorn nuts removed previously. Use a torque wrench to tighten the nuts to 15 in/lbs. **Do not torque the nuts to more than 15 in/lbs.** Pull each slide out firmly to their maximum travel to synchronize the travel.
- Install the upper rack by lowering the rack onto the rack mounting plates. The rack's water inlet must face toward the rear. Make sure the guide pins on each side of the rack engage securely into the guides on the mounting plates and the rack is level. See Figure 6-2.
- The rack can be adjusted to either height by lower or raising one side of the rack at a time. Grab the slide assembly with one hand and the rack with the other hand. **Do not adjust or remove the rack when there is glassware in the rack.**

- When the upper rack is in place, it limits the height of the glassware that can be washed. Ensure that the spray arms don't contact the glassware on the top or bottom racks. If very tall glassware or long pipets are to be washed, remove the upper rack, and place the glassware on the lower rack.

Figure 6-1

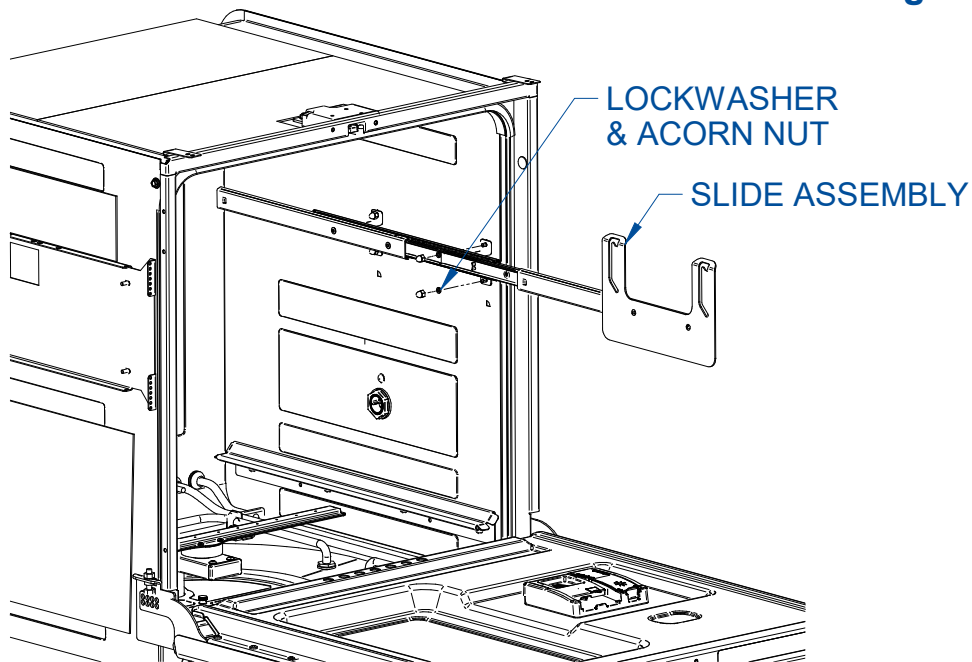

Remove the upper rack

- Slide the upper rack all the way out of the washer.
- Grasp the handles on each side of the rack, lift one side of the rack while putting slight pressure toward the opposite side of the rack. Once the rack clears the slide bracket slots, raise the rack off the opposite slide. See Figure 6-2.

Replace the upper rack

- The upper rack can be replaced by pulling each slide all the way out of the washer. Hold the rack by the handles above the slides making sure the rack's water inlet adapter is facing to the back of the washer, lower one side of the rack into the top position of the slide bracket rack seats. Once the rack is seated on one side, continue to lower the opposite side of the rack down to rest in the slide bracket seat. See Figure 6-2.
- The rack can then be moved to the lower position if required.

Raise the upper rack height

- To raise the rack to the upper position, slide the upper rack all the way out.
- Grasp the handle on one side of the rack, lift the rack straight up while letting the rack bracket slots guide the rack to the top of the slots and then out to the upper rack bracket pin seats. Repeat this process on the opposite side. Make sure the rack pins are setting securely in all four upper rack bracket pin seats. See Figure 6-2.

Lower the upper rack height

- To move the rack to the lower position, slide the upper rack all the way out.
- Grasp the handle on one side of the rack, lift the rack straight up and then back while letting the rack bracket slots guide the rack down to the lower rack bracket pin seats. Repeat this process on the opposite side. Make sure the rack pins are setting securely in all four lower rack bracket pin seats. See Figure 6-2.

Figure 6-2

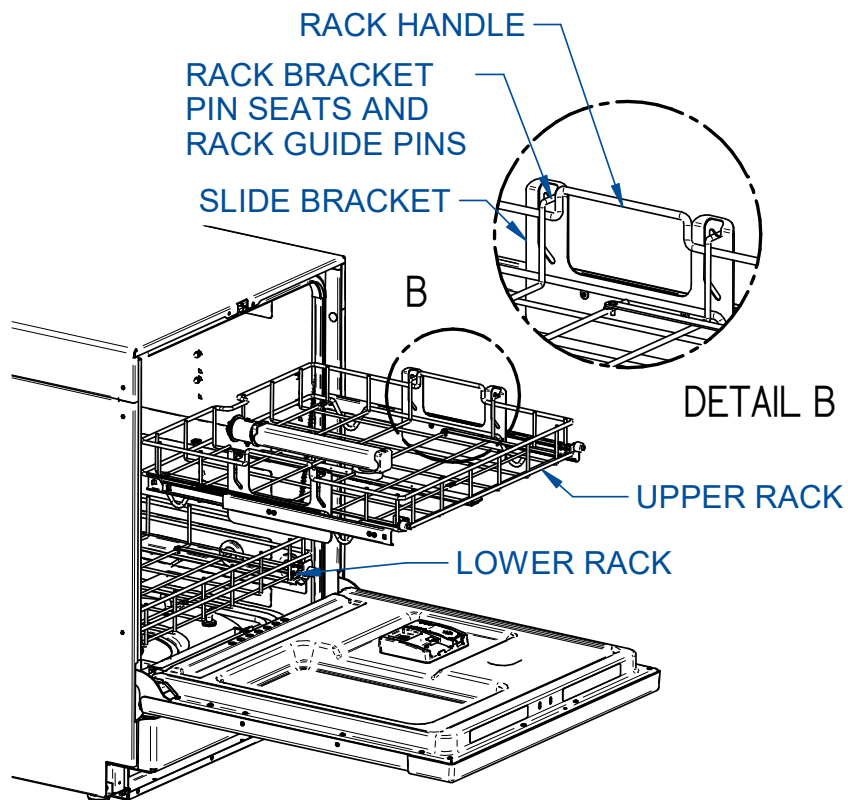

FlaskScrubber Spindle Rack

The FlaskScrubber Vantage Glassware Washers upper and lower spindle racks with glassware holders are designed for narrow-necked glassware such as volumetric flasks, Erlenmeyer flasks, graduated cylinders, Kjeldahl flasks, test tubes, BOD bottles and digestion tubes.

For versatility, two sizes of spindles are provided with the washer: (36) 0.25" (6.35 mm) OD and (10) 0.125" (3.18mm) OD spindles. Several optional inserts can be placed in the rack to support various configurations of glassware. See [Section 9: Accessories & Consumables](#) for available options.

Each spindle, or spindle arm, can be removed with the supplied wrench and replaced with plugs included with the washer. By removing the front or rear spindle arm assembly and reinstalling it at a 45° angle, longer items such as graduated cylinders up to 24" long can be washed. Some of the spindles may need to be removed and plugged to provide the room needed for longer labware. Refer to Figure 6-3.

Optional top racks are available for the FlaskScrubber Vantage to expand the washer's capacity to accommodate many types of glassware. An Upper Spindle Rack with 36 spindles and slides (Catalog Number 4668500) is available.

Figure 6-3

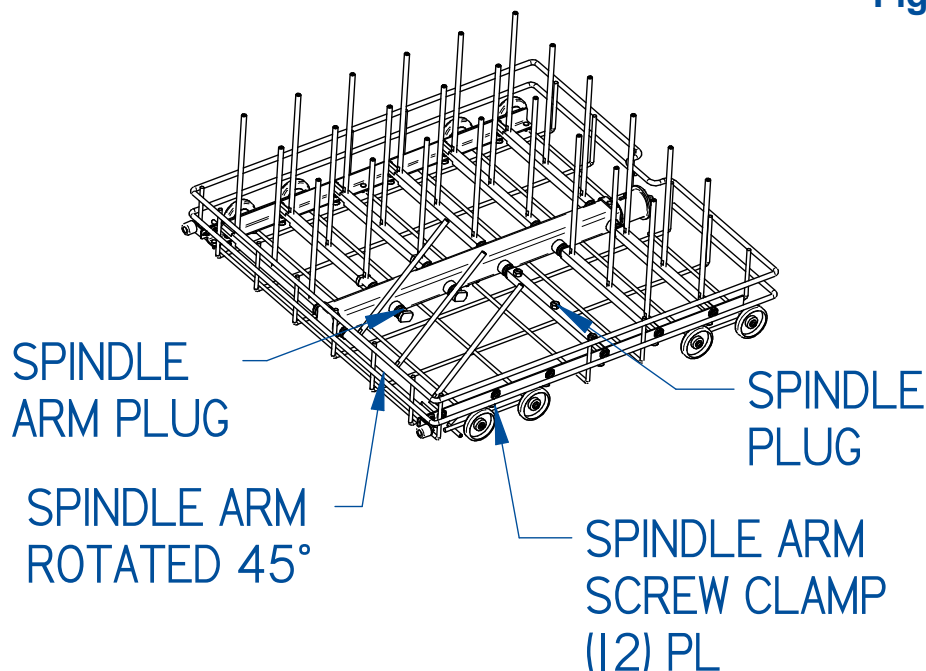

Liquid Detergent and Neutralizing Acid Rinse Dispense Systems

FlaskScrubbers Vantage models come standard with the Automatic Detergent and Rinse Aid Dispense Systems. The Automatic Liquid Dispense Systems are available as options for all other models. See [Section 9: Accessories & Consumables](#) for available options.

These dispensers allow liquid detergent and rinse aid to be dispensed from bulk containers on all Under counter or Freestanding Glassware Washers built after 09/20. Detergent is dispensed from a 1-gallon (3.8 L) container and rinse aid is dispensed from a 1.05-quart (1L) container. The dispense volume of detergent and rinse aid may be set by the user. Each dispenser may be purchased and installed individually or as a set.

If both automatic dispense systems are installed there will be two new Factory Programs available, Intense and Extreme. These programs are set to dispense detergent and rinse aid from the automatic dispense systems. If you choose to use the detergent dispenser (Soap Cup) and rinse aid reservoir in the door, with either of these programs a new program would need to be created and programmed to dispense from the Soap Cup. Likewise, if you wish to use the automatic dispense system with any of the other factory programs a new program will need to be created by copying the desired program and editing the dispense settings.

Installing the Liquid Detergent and Neutralizing Acid Rinse Dispense Systems

Note: This option requires that software version 1068800 rev D or later be installed in the unit. The washer's software version can be seen on the About page. Go to <https://www.labconco.com/resources/software-apps> for the latest CleanWorks software and instructions for updating your washer.

- Disconnect the power to the Glassware Washer.
- Remove both back and side panels of the Glassware Washer if it is a Freestanding model. Or remove both the right and left side cover panels from the base if it is an Undercounter model. The insulation will need to be raised to expose the cover plates mounted to the base. See Fig. 6-5.
- Attach the pump assemblies to the right side of the base of the Glassware Washer using screws and nuts as shown. See Fig. 6-4.

Figure 6-4

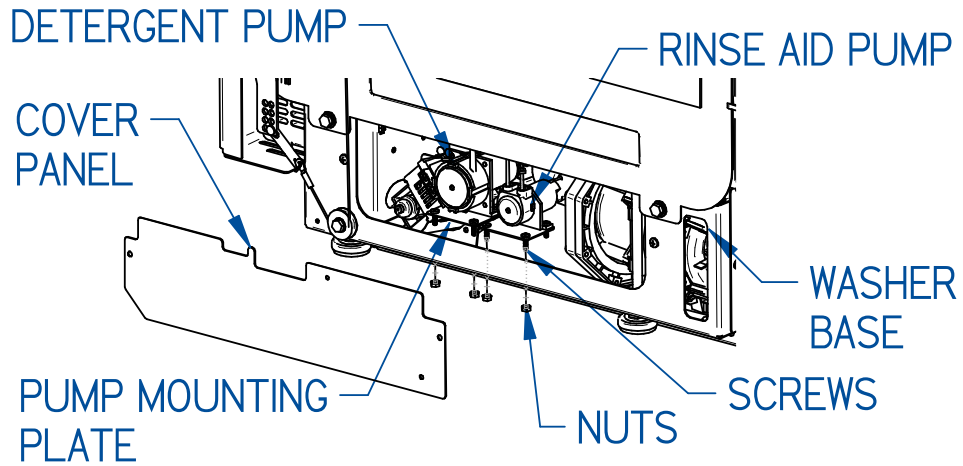

- Route the end of the harness connected to the pumps behind the electrical box to the left side. Plug the harness into the receptacle on the back left side of electrical box as shown. See Figure 6-5. Make sure the wiring does not interfere with the wash pump fan or the drain valve actuator linkage. Reinstall this cover panel. (Undercounter models only)

Figure 6-5

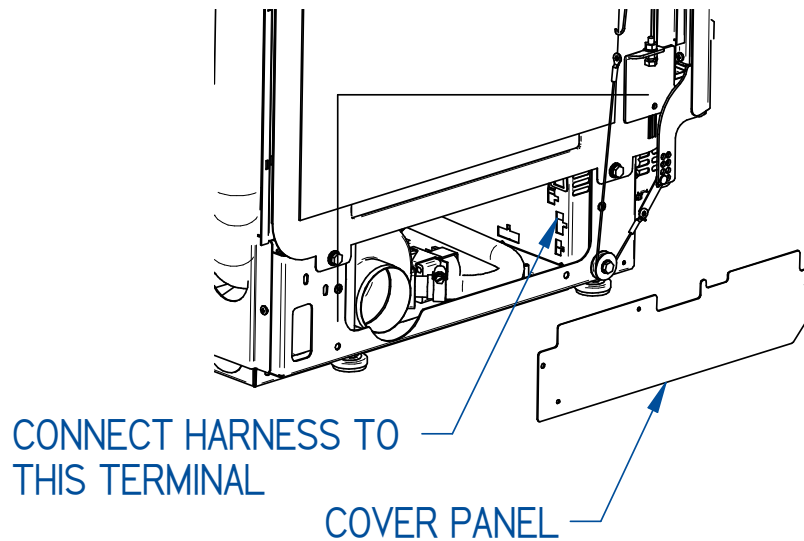
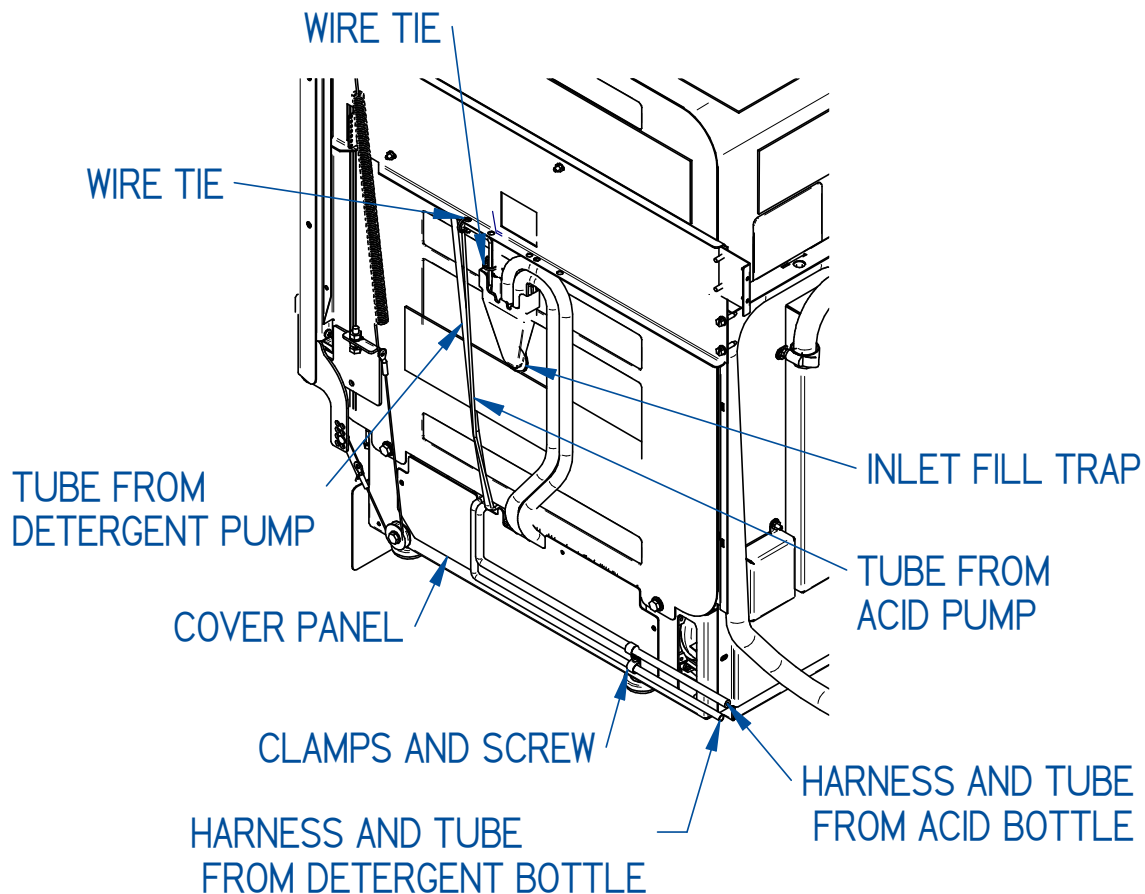

Figure 6-6



- Route tubes that are attached to the outlets of the pump(s) to the inlet fill trap as shown. Cut off excess length of tubing and insert into the trap. Secure with wire ties to the inlet fill trap and to the horizontal flange above the trap. See figure 6-6.
- Connect tubes from detergent and rinse aid bottles to the inlet tube on the appropriate pump. Connect the electrical connectors from the bottle(s) to the appropriate connector in the pump harness. Refer to Wiring Diagrams in Appendix D.
- Reinstall the cover panel making sure that all hoses and wires exit thru the slots as shown and are not pinched. Clamp the harness and tubes from the bottles to the cover panel. (Undercounter models only)
- Reinstall side panels. Reinstall the back panel routing the hoses out the back. (Freestanding models only)
- Position the detergent and/or the acid rinse bottles in a location where it will be convenient to replenish detergent or rinse aid solutions.

- Reconnect power to the Glassware Washer. The detergent dispense system and rinse aid dispense system are both enabled when they are connected to the Glassware Washer. This can be verified in the Accessories Screen.

Using the Liquid Detergent and Neutralizing Acid Rinse Dispense Systems

When liquid detergent and neutralizing acid rinse are first added to their dispense containers or if the containers are permitted to empty completely, the dispense pumps and supply tubing must be purged of air. If not done, a wash cycle could be run with insufficient detergent or neutralizing acid rinse. When refilling the containers follow this same procedure except it is not necessary to purge the system if the containers were not permitted to empty completely.

- Remove the cap from the detergent bottle and remove the draw tube and level switch assembly.
- Fill the bottle with detergent or replace the empty bottle with a new one-gallon bottle of detergent. Replace the draw tube, level switch assembly and the cap.
- Remove the draw tube and cap on the rinse aid bottle and remove the level switch assembly.
- Fill the bottle with rinse aid or replace the bottle with a new 1L bottle of rinse aid. Replace the level switch assembly and the cap and reinsert the tube into the cap.
- After initially filling or replenishing detergent or rinse aid it is necessary to fill the plumbing system. Enter the Diagnostics mode by selecting 'About' in the Help screen and then 'Diagnostics'. Select the DETERGENT PUMP 1 or RINSE AID PUMP 1. To start the pump, select 'OK' from the confirmation pop-up. The pump will run for approximately 30 seconds. Repeat this until the detergent or rinse aid is flowing into the tank at the water inlet on the right side of the tank. Repeat this prime process on the other pump if installed,
- Program the quantity of detergent and/or rinse aid that will be dispensed during a wash/rinse cycle by entering the programming screen, select the program to copy and edit or create a new program and modify the detergent and rinse aid sources for each wash and rinse as required. See detailed instructions in the User's Manual.

Drain Water Cooling Kit

This kit provides plumbing components, solenoid valve and electrical connections necessary to reduce drain water temperature to <140° F (<60°C). When the washer's drainage pump is activated, the solenoid valve opens, releasing the flow of cold tap water down the same air gap the washers drain hose is connected to.

A supply of cold water must be available. It is recommended that the cold-water temperature is colder than 54°F (12°C). Warmer water temperature will cause the drain

water temperature to be higher. The cold-water supply must be capable of a flow rate of 3.5 GPM (13.2 LPM) and a pressure of 20-120 PSI (138-827 kPa). The inlet connection to the valve is a 3/8" compression fitting.

Installation of the Drain Water Cooling Kit

- Disconnect the power to the washer.
- Remove the back panel and right-side panel of the washer if it is a Freestanding model or the cover panels of an Undercounter model.
- Attach the water valve assembly to the rear flange of the base using the screws provided. See figure 6-7.
- Connect the wires coming from the water valve assembly to the mating 3 pin Molex connector in the wiring harness of the washer. The 3-pin connector is located on the right-hand side of the base near the wash pump.

Figure 6-7

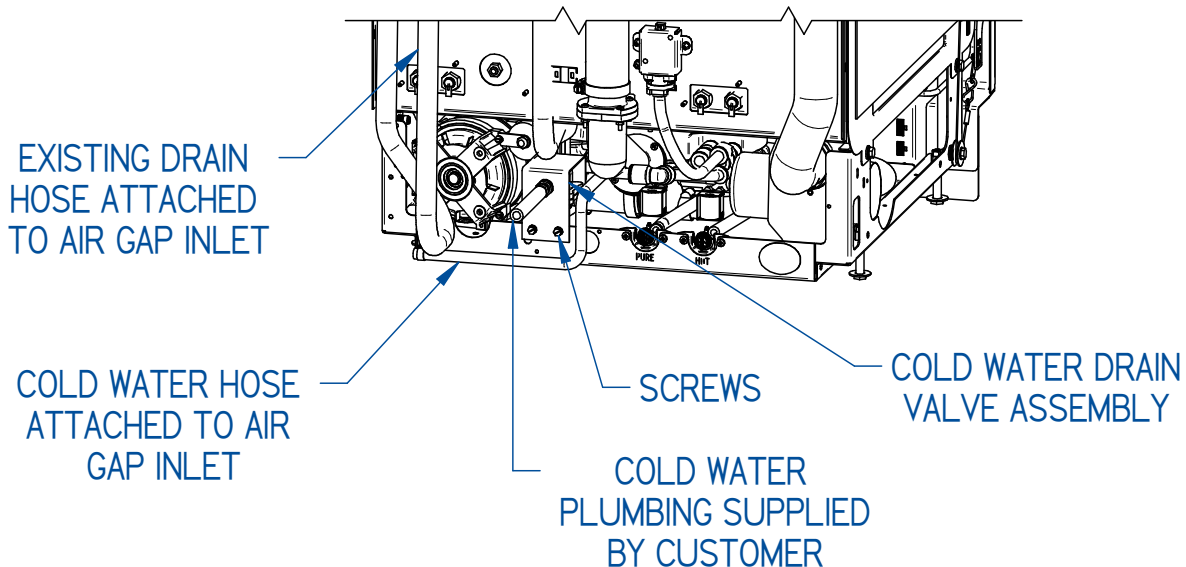

- Connect the cold-water supply to the cold-water valve assembly. Do not allow the tube to kink when the washer is placed into its operational location. If necessary, replace the straight fitting on the cool water valve with the supplied elbow.
- Replace the back panel if it is a Freestanding model. Remove the knockout in the cover panel and reattach the panel if it is an Undercounter model.
- Attach the hose from the valve to a Twin Inlet High Flow Air-gap suitable for dishwasher applications. This may be obtained from a plumbing supply store.
- Attach the drain hose from the glassware washer to the other inlet of the Airgap.
- Attach the Air-gap outlet to the building drain.
- Turn on the electrical power.

Printer Kit for FlaskScrubber and SteamScrubber

This kit will add a printer and printer connection to the glassware washer. This kit is only available on 2020 models or later.

Installation of Printer Kit

- Disconnect power to the washer.
- Remove the rear and left side panel on a freestanding glassware washer.
- Remove the lower panels on the washer base on undercounter models.
- Install the Printer Connector on the inside the base and secure with two #6 lock washers and screws. See figure 6-8.

Figure 6-8

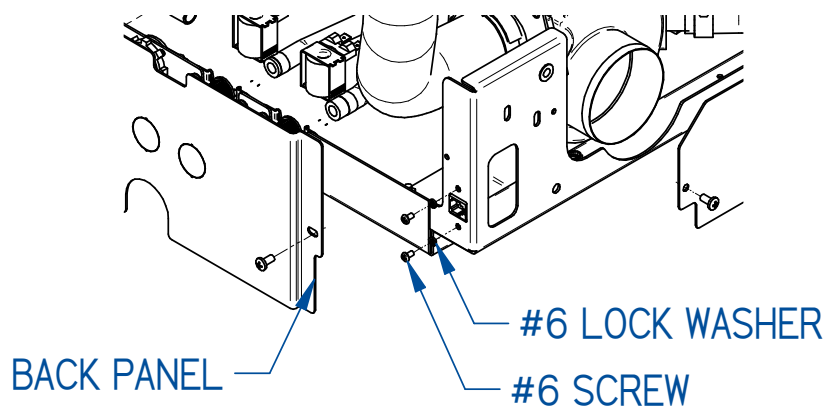

- Connect the Printer Wire Assembly to the Printer Connector at the back of the electrical enclosure. See figure 6-9.

Figure 6-9

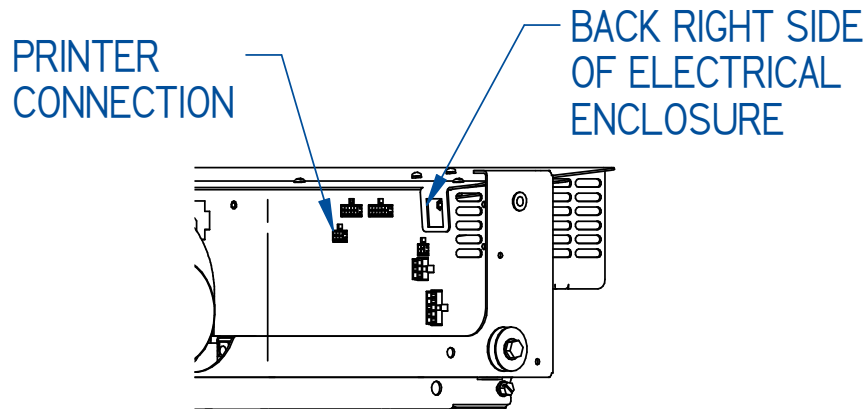

- Reinstall the panels and reconnect power.
- Connect the flat modular cable from the printer to the printer connector.
- Turn on the printer. The glassware washer will connect automatically to the printer once power is restored.
- Go to the home screen and select the printer. You can then select your preferences.

Installation of Vantage Printer Kit

- Connect the flat modular cable from the printer to the printer connector inside the Vantage cabinet. See Figure 6-10.
- Turn on the printer. The glassware washer will connect automatically to the printer
- Go to the home screen and select the printer. You can then select your preferences.

Figure 6-10

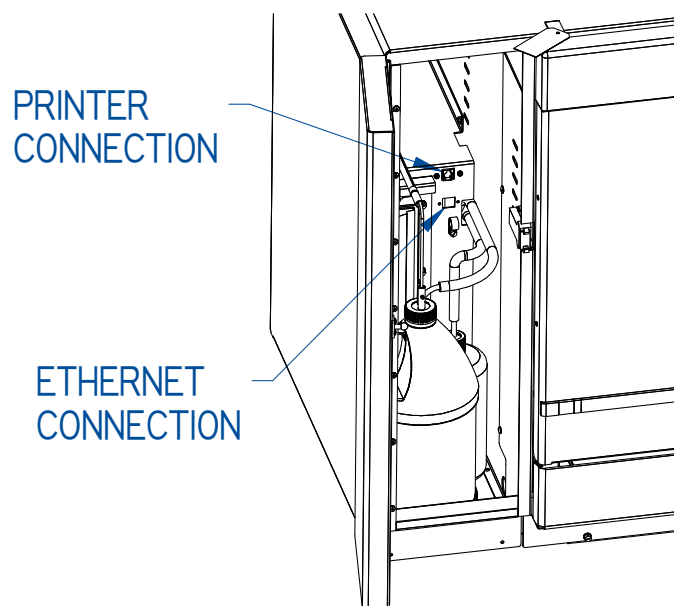

7: Diagnostics/Troubleshooting

To be effective in properly servicing laboratory equipment, it is essential to be able to troubleshoot any problem and gain a clear and concise root cause to the problem to accurately correct the problem. This section is split into two sections. The first is dealing with Basic Troubleshooting for a wide range of issues. The second section gives detailed steps at finding the root causes of the Alarms that may be displayed.

Alarms

During a wash cycle there are multiple operations that must occur to successfully complete the desired programmed cycle. The washer is designed to monitor the progress of a cycle and provide an alarm to alert the user should an abnormal event or component failure occur. Information is displayed to identify the alarm situation, which may be Fatal or Non-Fatal to the running program. See Table 7-1 for a list of all Alarm Codes and their description. Fatal alarms during a cycle will drain the washer, end the program, and display a red **X** on the segment in which the error occurred. Non-Fatal alarms will allow the program to proceed. The display will show a yellow check mark at any completed segment in which a non-fatal alarm occurred. Touching the red **X** or yellow check will display alarm details and the time of occurrence. Any Alarm Code will also be displayed and can be viewed in the data log. When troubleshooting, the data log file can be very helpful to determine when the fault occurred during the cycle. Refer to Table 7-1 for a list of alarm codes and their meaning.

Table 7-1

ALARM CODE	ALARM DESCRIPTION	CONDITION	RESPONSE
A1	LOW AUTO RINSE AID 1	Low Rinse Aid in Auto Dispense *	NON-FATAL
CS	CONDUCTIVITY FAILED	Conductivity sensor is not responding **	NON-FATAL
D1	LOW DETERGENT 1	Low Detergent in Auto Dispense *	NON-FATAL
DF	DRAIN FAIL	Pressure Sensor did not reach 0 during drain	FATAL
DL^	DOOR LATCH FAIL	Door unlatched during cycle	FATAL
DO	DOOR OPEN	Door not fully closed	FATAL
FF	FILL FAIL	Low Water after allotted fill time expires	FATAL
FI	FIRMWARE	Firmware Unresponsive	NON-FATAL
HW^	HIGH WATER	Fill Level too high during segment	FATAL
LT	LOW TEMP	Temperature Set Point not achieved	FATAL
NW	NO WATER	No or Low Water during segment	FATAL
OV^	OVERFLOW	Water detected in base	FATAL
PC	PROGRAM CANCELED	User initiated Program Cancel	FATAL
PF	POWER FAIL	Power Loss occurred	NON-FATAL
PP	PROGRAM PAUSED	User initiated Program Pause	NON-FATAL
RA	RINSE AID LOW D-CUP	Low Rinse Aid in Detergent Dispense Cup	NON-FATAL
SS	STEP SKIPPED	User initiated Segment Skip	NON-FATAL
TA	HIGH TEMP ALARM	Temperature sensor reading above 110C	FATAL
TS^	TEMP SENSOR	Temp Sensor error or disconnected	FATAL
WQ	CLEANPOINT FAIL	Clean water quality/conductivity not reached **	NON-FATAL
WR	CLEANPOINT PASS	Clean water quality/conductivity reached. **	NON-FATAL
FV	FILL VALVE FAILURE	Water indicated in sump while inactive	DRAIN SUMP

* Only on models with optional Auto Dispense or Rinse-Aid Dispense accessory installed.

** If equipped.

^ Fatal Alarm that requires a power reset to clear alarm once issue is resolved

Running Diagnostics

To verify the washer or the washer's components are operating properly, diagnostics can be used to test individual parts or systems before and after servicing, (i.e., drain or fill) as detailed below. Refer to Fig. 7-1 to familiarize yourself with the control panel before you begin these procedures. Several variables can affect these tests so the test should be allowed to run to completion and the results should be used as a reference only. Operation of each component should be determined independent of the displayed results. Refer to Trouble Shooting Table 7-2 below if components or systems are found to be functioning incorrectly.

Figure 7-1

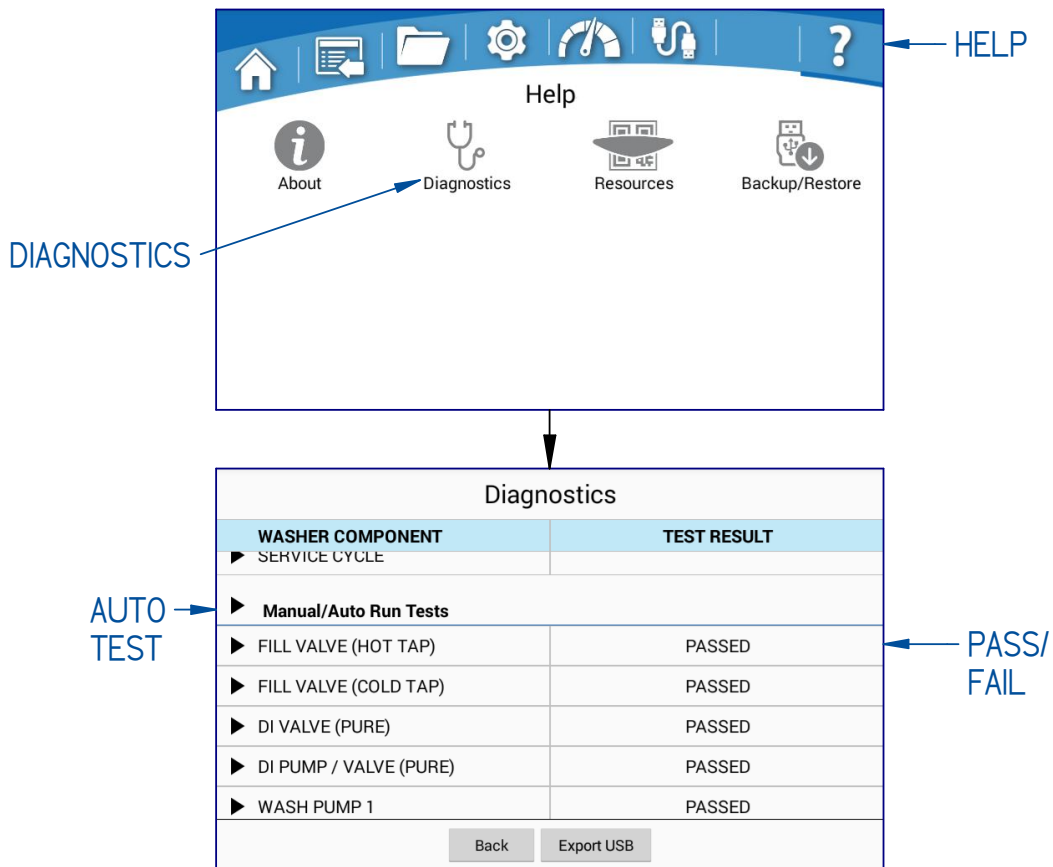

From any screen touch the HELP Icon.

- Touch the Diagnostics icon.
- Scroll down, select the desired test, and confirm as follows.

Manual Only Run Test

The Manual Auto Run Test provides a way to test the timing and fill levels of the washer's water fill systems, drain system, and each AC voltage component independently.

Fill All-The-Way

Fill All-The-Way can be used to test the hot tap water fill valve and water level sensor set point. Press FILL ALL-THE-WAY and confirm, the tap valve will open to allow water into the tank for a set amount of time or until the programed water level is reached. The

test can be stopped any time by pressing FILL ALL-THE-WAY again. During the test the water level will be displayed. If the water level set point is reached in the allotted time a Pass or Fail and the calculated flow rate will be displayed. Several variables can affect these test results. Because the flow rate calculation is based on the time to do a normal fill from empty, if water is present before starting the test or if the test is ended prematurely the results will be affected. The pass/fail and flow rate results of this test should be used as a reference only. When the fill is complete open the door and visually check the water level. The water should be up to and just touching the bottom of the heater. If the water level is not correct refer to Troubleshooting Table 7-2 below.

Pure Fill All-The-Way

Pure Fill All-The-Way can be used to test the pure water fill valve, pure water pump and water level sensor set point. Press PURE FILL ALL-THE-WAY and confirm, the pure water valve will open, and the pure water pump will operate (if turned on) to pump pure water into the tank for a set amount of time or until the programmed water level is reached. The test can be stopped any time by pressing PURE FILL ALL-THE-WAY again. During the test the water level will be displayed. If the water level set point is reached in the allotted time a Pass or Fail and the calculated flow rate will be displayed. Several variables can affect these test results. Because the flow rate calculation is based on the time to do a normal fill from empty, if water is present before starting or the test is ended prematurely the test the results will be affected. The pass/fail and flow rate results of this test should be used as a reference only. When the fill is complete open the door and visually check the water level. The water should be up to and touching the bottom of the heater. If the water level is not correct refer to Troubleshooting Table 7-2 below.

Drain All-The-Way

Drain All-The-Way can be used to test the drain valve and drain pump together. With water in the tank, press DRAIN ALL-THE-WAY and confirm, the drain valve will open and three seconds later the drain pump will come on. The wash pump may cycle off and on up to three times if there is no change in the water level. The test will run for a total of three minutes and can be stopped any time by pressing DRAIN ALL-THE-WAY again. During the test the water level will be displayed. Once the test is complete, a Pass or Fail and the calculated flow rate will be displayed. Several variables can affect these test results. Because the flow rate calculation is based on the time to do a normal drain from full, if the water level is low before starting or the test is ended prematurely, before the 3 minutes allowed, the test results will be affected. The pass/fail and flow rate results of this test should be used as a reference only. When the drain is complete open the door and visually check to make sure there is no water in the tank's sump. If water is still present refer to Troubleshooting Table 7-2 below.

Wash Pump 1

Press and confirm Wash Pump 1, after a short delay the wash pump will turn on for approximately 10 seconds. The display will show Complete when the test has ended. Operation can be confirmed visually or audibly by running the test with water in the tank.

Heater 1

Press and confirm Heater 1, after a short delay the heater will turn on for approximately 10 seconds. The display will show Complete when the test has ended. The proper operation of the heater can best be determined via an amp meter on the power line. Operation can also be confirmed by a heat rise in the washer after running the test.

Heater 2&3 (High Heat Models only)

Press and confirm Heater 2&3, after a short delay heaters 2&3 will turn on for approximately 10 seconds. The display will show Complete when the test has ended. The proper operation of the heaters can best be determined via an amp meter on the power line. Operation can also be confirmed by a heat rise in the washer after running the test.

Drain Valve

Press and confirm Drain Valve, after a short delay the drain valve will turn on for approximately 10 seconds. The display will show Complete when the test has ended. The proper operation of the valve can best be determined via an amp meter on the power line. Operation can sometimes be confirmed audibly by listening for the valve to acuate. Note: the drain pump does not come on during this test, use Drain All-The-Way to drain water from the tank.

Drain Pump

Press and confirm Drain Pump, after a short delay the drain pump will turn on for approximately 10 seconds. The display will show Complete when the test has ended. The proper operation of the pump can best be determined via an amp meter on the power line. Operation can sometimes be confirmed audibly by listening for the pump to run. Note: the drain valve does not come on during this test use Drain All-The -Way to drain water from the tank.

Manual/Auto Run Test

Manual/Auto Run Test provides a way to test each DC voltage component independently or by pressing and confirming the Auto Run Test the unit will run through and test each DC component as detailed below. When complete, the unit will display

Pass or Fail and the DC current in milliamps based on the acceptance criteria of the individual components.

Fill Valve (Hot Tap)

Press and confirm Fill Valve (Hot Tap), after a short delay the tap valve will turn on for approximately 10 seconds. The display will show Pass or Fail and the average current in milliamps. The proper operation of the valve can be verified by checking to see if water is filling the tank.

DI Valve (Pure)

Press and confirm DI Valve (Pure), after a short delay the DI valve will turn on for approximately 10 seconds. The display will show Pass or Fail and the average current in milliamps. The proper operation of the valve can be verified by checking to see if water is filling the tank.

DI Pump (Pure)

Press and confirm DI Pump (Pure), after a short delay the DI valve will turn on for approximately 10 seconds. The display will show Pass or Fail and the average current in milliamps. Proper operation can be verified audibly by listening for the pump to turn on. Note: If the pure water source is pressurized, the DI pump is not required and can be turned off in the Accessories Screen.

Detergent Cup

Close the detergent cup door. Press and confirm Detergent Cup, after a short delay the detergent cup coil will be energized. The display will show Pass or Fail and the average current in milliamps. The proper operation of the Detergent Cup can be verified by checking to see if the door opened.

Dry Blower

Press and confirm Dry Blower, after a short delay the blower will turn on for approximately 10 seconds. The display will show Pass or Fail and the average current in milliamps. Proper operation can be verified audibly by listening for the blower to turn on.

Electronic Cooling Fan

Press and confirm Electronic Cooling Fan, after a short delay the fan will turn on for approximately 10 seconds. The display will show Pass or Fail and the average current in milliamps. Proper operation can be verified audibly by listening for the fan to turn on.

LED Light (If equipped)

Press and confirm LED Light, after a short delay the light will turn on for approximately 10 seconds. The display will show Pass or Fail and the average current in milliamps. Proper operation can be verified visually by looking for the light to turn on.

Printer (If equipped)

Press and confirm Printer, after a short delay the printer will print. The display will show Pass or Fail and the average current in milliamps. The proper operation of the printer can be verified by checking the printout.

Detergent Pump 1 (If equipped)

Press and confirm Detergent Pump 1, after a short delay the pump will turn on for approximately 30 seconds. The display will show Pass or Fail and the average current in milliamps. The proper operation of the pump can be verified by checking to see that detergent is being drawn up through the suction lance at the detergent bottle.

Note: Use this feature to prime the detergent hoses when adding new or replacing empty detergent bottles.

Rinse Aid Pump 1 (If equipped)

Press and confirm Rinse Aid 1, after a short delay the pump will turn on for approximately 30 seconds. The display will show Pass or Fail and the average current in milliamps. The proper operation of the pump can be verified by checking to see that rinse aid is being drawn up through the suction lance at the rinse aid bottle.

Note: Use this feature to prime the rinse aid hoses when adding new or replacing empty rinse aid bottles.

Door Latch

Close the door. Press and confirm Door Latch, after a short delay the door latch coil will be energized. The display will show Pass or Fail and the average current in milliamps. The proper operation of the door latch can be verified by checking to see that the door opened.

Diagnostic Report

Once the desired tests are completed a report can be exported either to a USB drive or via email. The report will show all test and the results of the test performed as shown in Figure 7-2.

Figure 7-2

Fill All-the-way PASSED 9.200 L/min
 Pure Fill All-the-way
 Drain All-the-way FAILED 6553.500 L/min
 Wash Pump 1 COMPLETE
 Heater 1 COMPLETE
 Drain Valve COMPLETE
 Drain Pump
 Fill Valve (Hot Tap) PASSED, AMP=504.000 mA
 DI Valve (Pure) PASSED, AMP=508.000 mA
 DI Pump (Pure)
 Detergent Cup
 Dry Blower 1 PASSED, AMP=2740.000 mA
 Electronics Cooling Fan FAILED, AMP=6.000 mA
 LED Light
 Detergent Pump 1
 Rinse Aid Pump 1
 Door Latch PASSED, AMP=3640.000 mA

Troubleshooting

This section details common troubleshooting for your Glassware washer.

Refer to the following table if your Glassware Washer fails to operate properly. If the suggested corrective actions do not solve your problem, contact Labconco Product Service for additional assistance.

Table 7-2

Problem	Alarm Code	Possible Cause	Diagnostic Test	Possible Corrective Action
Low Auto Rinse Aid (If Equipped)	A1	Rinse Aid level low.	Check Rinse Aid level.	Refill or replace Rinse Aid bottle.
		Float movement restricted.	Check Sensor Screen for reading and float function.	Clean float and dip tube.
		Bad wiring connection.	Check wire connections.	Correct wiring.
		Auto Rinse Aid not used.		Turn Auto Rinse Aid dispense off in Accessories. Dismiss alarm.

Problem	Alarm Code	Possible Cause	Diagnostic Test	Possible Corrective Action
Conductivity Sensor (If Equipped)	CS	Conductivity sensor disconnected.	Check wire connections.	Correct wiring.
		Bad conductivity sensor.	With water in sump, check Sensor Screen for a conductivity value.	If no reading and wiring connected replace conductivity sensor.
Low Auto Detergent	D1	Auto Detergent level low.	Check Auto Detergent level.	Refill or replace Detergent bottle.
		Float movement restricted.	Check Sensor Screen for reading and float function.	Clean float on dip tube.
		Bad wiring connection.	Check wire connections.	Correct wiring.
		Auto Detergent not used.		Turn Auto Detergent dispense off in Accessories. Dismiss alarm,
Drain Fail	DF	Clogged Sump screen.	Visual inspection.	Clean sump screen.
		Drain line partially restricted, kinked or improperly installed.	In Diagnostics Drain All-The-Way: check for water output from drain hose and for no water in sump after complete.	Fail: Clear drain line, remove kink or correct installation.
		Drain Valve not operating.	Drain Valve Test: Listen for valve or check for AC power to valve when actuated.	Fail: If valve is getting power replace valve. If no power, check wiring, relay or IOB output
		Drain Pump not operating.	Drain Pump Test: Listen for pump or check for AC power to valve when actuated.	Fail: If pump is getting power replace pump. If no power, check wiring, relay or IOB output.

Problem	Alarm Code	Possible Cause	Diagnostic Test	Possible Corrective Action
		Pump lost its prime.	Drain-All-the Way Test: drain time and flow rate	Fail: Check drain hose for sumping between pump and high loop. Drain water from drain hose and retest Drain-All-the Way
		Defective Relay.	Check for 12VDC to drain pump and drain valve relay coils when actuated in diagnostics	If 12VDC to coil OK, replace valve
		Defective controller.	Check for 12VDC to drain pump and/or drain valve relay coils when actuated in diagnostics	If no 12VDC to coils and wiring OK, replace IOB. Contact Labconco Product Service.
		Defective fill level sensor.	With water in sump, check Sensor Screen for readings. Fill level sensor should be 0 when empty and >75mm full.	Fail: Replace and calibrate Fill Level Sensor.
Door Latch Fail	DL	Door switch opens during cycle.		Shut Door.
DL is a Fatal Alarm and requires a power reset to clear once fault is resolved.		Door switch not actuated.	Door Latch Test: Check door latch function.	Pass: Adjust door striker or door hinge pins for positive actuation of door switch/latch.
		Door latch switch/latch not working.	Check wire connections.	Fail: If latch is getting power replace latch. If no power, check wiring or IOB output

Problem	Alarm Code	Possible Cause	Diagnostic Test	Possible Corrective Action
Door Open	DO	Door switch is open when trying to start cycle.		Shut Door.
Fill Fail	FF	Improper water supply tap.	Fill All-The-Way tests Tap fill time and flow rate.	Fail: Make sure water is turned on with no restrictions.
				Tap water pressure must be at least 20 psi (138 kPa) and flow must be at least 1.25 gallons (4.7 liters)/minute.
		Improper water supply pure.	Pure Fill-All-the Way tests Pure fill time and flow rate.	Fail: Make sure pure water is turned on with no restrictions.
				DI water supply must have volume of 3.4 gallons (4.7 liters) per fill and flow of at least 0.9 gallons (3.4 liter)/minute.
		Defective fill valves.	Fill Valve Test (Hot Tap or Pure): Test valve operation.	Pass: Clean screens inside the inlet fittings of the water valves.
			Fill Valve Test (Hot Top or Pure): Test valve operation.	Fail: If valve is getting power replace valve. If no power, check wiring or IOB output
		Defective DI water pump.	Pure Pump Test: Test pump operation.	Fail: If pump is getting power replace. If no power, check wiring or IOB output

Problem	Alarm Code	Possible Cause	Diagnostic Test	Possible Corrective Action
		Air leak in tube connections to water level sensor.	<p>Check Sensor Screen: >75mm when full, no loss of pressure after 5 minutes.</p> <p>Fill washer. Check water level in transparent tubing to pressure sensor, water should not move up into the tube over time.</p>	Fail: Repair air leak. Or replace sensor.
		Defective fill level sensor or overflow switch	Check Sensor Screen: If water level is <75mm when full.	Recalibrate sensor. See Figure 4-19 & 4-20
		Defective controller.	Check output from IOB to both valves and DI pump.	Fail: Replace IOB.
Firmware	FI	Firmware not responding.		Power Reset, reinstall firmware or Factory Reset
High Water	HW	Water level set point to high.	Fill All-The-Way Water level over distribution tube.	Pass: Recalibrate sensor. See Figure 4-19 & 4-20
		Inlet Valve failure.	Check water inlet inside of tank for water leaking into tank when unit off.	Replace Inlet Valve
		Defective fill sensor	Check Sensor Screen: >125mm @ normal fill.	Pass: Recalibrate or replace sensor. See Figure 4-19 & 4-20
		Defective or incorrectly installed Ball Valve Seal	FlaskScrubber only. Water level goes high at spin up of wash cycle.	Reinstall or replace Ball Valve Seal (4656000)

Problem	Alarm Code	Possible Cause	Diagnostic Test	Possible Corrective Action
Low Temp	LT	Heater failure.	Heater/s Test:	Fail: If heaters are getting power and wires have conductivity, replace heater(s)
			Check resistance of heater for open circuit	If open replace heater.
		Defective controller.	Check for 12VDC input and AC output from Heater 1 Triac PCB.	Fail; No 12VDC replace IOB. No AC Replace Heater 1 Triac. Contact Labconco Product Service.
			Check for 12VDC input and AC output from Heater 2&3 Relay.	Fail; No 12VDC replace IOB. No AC Replace Heater 2&3 Relay. Contact Labconco Product Service.
		Defective temperature probe.	Check electrical connections. Verify temp sensor accuracy compared to T Couple.	Repair connections or replace sensor.
		Defective high temperature cut out T-Stat.	Check resistance of safety cut out T-Stat.	If open circuit at room temperature, replace T-Stat.
		High Altitude.	Check if altitude is over 2000 meters (6561 feet).	Change max temp setting to 88°C in Calibration Settings.
No Water	NW	Leak during wash or rinse segment.	Check for leaks both under and around washer.	Fix Leaks.
		Drain Valve failure during wash or rinse segment.	Check for draining during wash segment.	Replace drain valve.

Problem	Alarm Code	Possible Cause	Diagnostic Test	Possible Corrective Action
		Pressure Sensor failure.	Check for water level reading/change on Sensor Screen during fill.	Power reboot. Replace sensor.
		Pressure Sensor plumbing failure.	Fill tank with water and confirm pressure sensor reading is stable for 5 minutes.	Fix air leak in hose connections. Make sure tubing is pressed in fitting fully.
Overflow is a Fatal Alarm and requires a power reset to clear once fault is resolved.	OV	Water in base.	Check for leaks under wash tank.	Repair leaks under wash tank or inlet valves. Dry out sensor contacts, perform power reset.
Program Canceled	PC	Program canceled by operator or Fatal Alarm.	No action required.	No action required if manually canceled. Determine if caused by another Fatal Alarm.
Power Fail	PF	Power Outage.	No action required.	Program will resume at the beginning of interrupted segment.
Program Pause.	PP	Door opened or program paused by operator.	No action required.	Restarting program will resume where paused.
Low Rinse Aid Cup	RA	Rinse Aid in door low.		Refill Rinse Aid in door or dismiss alarm.
Step Skipped	SS	Segment Skipped by operator.	No action required.	Program will drain and begin next programmed segment.

Problem	Alarm Code	Possible Cause	Diagnostic Test	Possible Corrective Action
Temp Sensor	TS	Temperature Sensor failure.	Check Sensor Screen for temp reading.	If no reading and wiring is connected replace sensor.
Open buttons or display on control panel inoperable or controls malfunction		Microprocessor memory error.		Perform Power Reset and/or Factory Reset.
		Keypad or display defective.		Replace keypad or display or IOB.
Detergent cup in door fails to open		Glassware interfering with cup door.		Move glassware.
		Malfunction of cup.	Detergent Cup Test: with door closed	Fail: If cup is getting power and wiring has continuity replace Detergent cup.
		D-cup latch fouled.	Manually test door operation.	Clean D-cup latch.
Poor drying		Dry temperature too low.		Program hotter dry temperature.
		Flask, beaker, or labware with concave bottoms not loaded correctly.		Tilt these articles when loading so that water drains off.

Problem	Alarm Code	Possible Cause	Diagnostic Test	Possible Corrective Action
		Recondensation.		If labware is left in the washer, recondensation may occur. Open latch or program Auto Unlock after completion of cycle to allow moisture-laden air to escape.
		Dry time too short.		Program longer time.
		Heater 1 disconnected or malfunctioned.	Heater 1 Test.	Reconnect or replace heater.
		Blower disconnected or malfunctioned.	Dry Bower Test.	Reconnect or replace blower.
Poor washing results		Water is not hot enough.	Check Wash water temperature setting.	Should be at least 120°F (49°C). Recommended temperature is 150°F (66°C).
		Improper loading.	Check washer loading.	instructions in <i>Chapter 7</i> in of User's Manual.
		Detergent too old or amount wrong.		Replace detergent or change quantity used.
		Detergent caked in D-Cup.	Check washer loading.	Clean D-Cup. Replace with fresh detergent. Check water inlet temperature. Should be at least 120°F (49°C).
		Insufficient wash time.		Increase wash cycle time.
		Wash arms not spinning or not spraying.		Remove and clean wash arms. Adjust Rack bumpers out.

Problem	Alarm Code	Possible Cause	Diagnostic Test	Possible Corrective Action
		Glassware interfering with detergent cup door.		Move glassware.
		Glassware interfering with wash arm.		Move glassware.
Tank and inner door have surface rust		Glassware is contaminated with acids.		Pre-rinse glassware. Clean with stainless steel cleaner and soft cloth.
		Ferrous material introduced in washer		Remove rusted item, clean surface rust with rust remover.
Washer does not run		No power to washer.		Check fuse or circuit breaker.
		Improper wiring.	Check wiring to unit	Correct wiring.
		12VDC power supply.	Check power in and out of 12V power supply.	If input OK and output < 10VDC replace power supply.
Washer door opens and closes badly		Cabinet opening is not square.		Correct opening with leveling feet.
		Door hitting counter-top mounting screws.		Adjust mounting screws or lower washer.
		Door not sealing or door too tight.		Adjust hinge pins, door striker or latch position. If unable to achieve seal, replace door seal.
Washer leaks		Sump Screen dirty, starving pump.	Check sump screen for debris restricting water flow.	Clean sump screen.

Problem	Alarm Code	Possible Cause	Diagnostic Test	Possible Corrective Action
		Improper detergent.	Check detergent for foaming.	Use non-foaming detergent. Use only proper amount of detergent.
		Tank sump gasket.	Check sump fasteners.	Tighten nuts or replace O-ring. Do not over tighten nuts.
		Washer is not level.	Check with level.	Adjust leveling feet.
		Loose connection at hose clamps.		Tighten hose clamp.
		Loose connection at fill valve.	Check water supply/ fill valve connection.	Tighten or replace seal.
		Tube in Push fitting not seated.		Push tubing fully into push fittings.
		Obstruction in drain line.		Remove obstruction.
		Washer overfilling.	Check operation of fill sensor and over fill switch	Recalibrate or replace water level sensor or switch. See Figure 4-19 & 4-20
			In diagnostics Fill-All-the-Way. In Sensor page, check that pressure sensor value holds for 5 minutes.	If pressure goes down, fix air leaks in tube fittings, or replace sensor.
Washer leaks around door seal		Improper installation.		Check the cabinet opening to see if it is square and aligned properly with the door, adjust feet.
		Unit not level.		Adjust feet to level unit.

Problem	Alarm Code	Possible Cause	Diagnostic Test	Possible Corrective Action
		Door latch.	Check door latch for proper sealing.	Adjust hinge pins, door striker or latch position. If unable to achieve seal, replace door seal.
Ethernet connectivity		No Network.	Confirm network is available.	Connect to valid network.
		DHCP Enabled, setting switched off.	Check DHCP Enabled setting.	Turn DHCP Enabled ON.

8: Service Procedures

Once the root cause of a failure has been determined, it may be time to replace parts. When major part replacement of the various washer systems is required, use this section's procedures for assistance.

Maintenance Safety Precautions



The following safety precautions must be followed by all personnel servicing the equipment.

- Wear safety glasses, and/or additional eye and face protection as required by your Health & Safety Department.
- Wear gloves, and/or additional skin protection as required by safety instructions for cleaning/disinfecting chemicals used. Consult your Health & Safety Department for additional skin protection requirements.
- No loose fitting clothes
- Wear close-toed shoes
- Should you remove any panels that expose moving or electrical parts, you must follow these instructions before doing so:
 - Disconnect main electrical service to the unit.
 - Never touch moving parts such as fan blades or blower wheels.



Washer Layout and Landmarks

Before getting into the washer to perform service, it is important to know where the major systems and their parts are. In the field, you will not have the luxury of seeing where everything is unimpeded. Refer to Fig 8-1 below to serve as a roadmap to systems in the base of the unit.

Figure 8-1

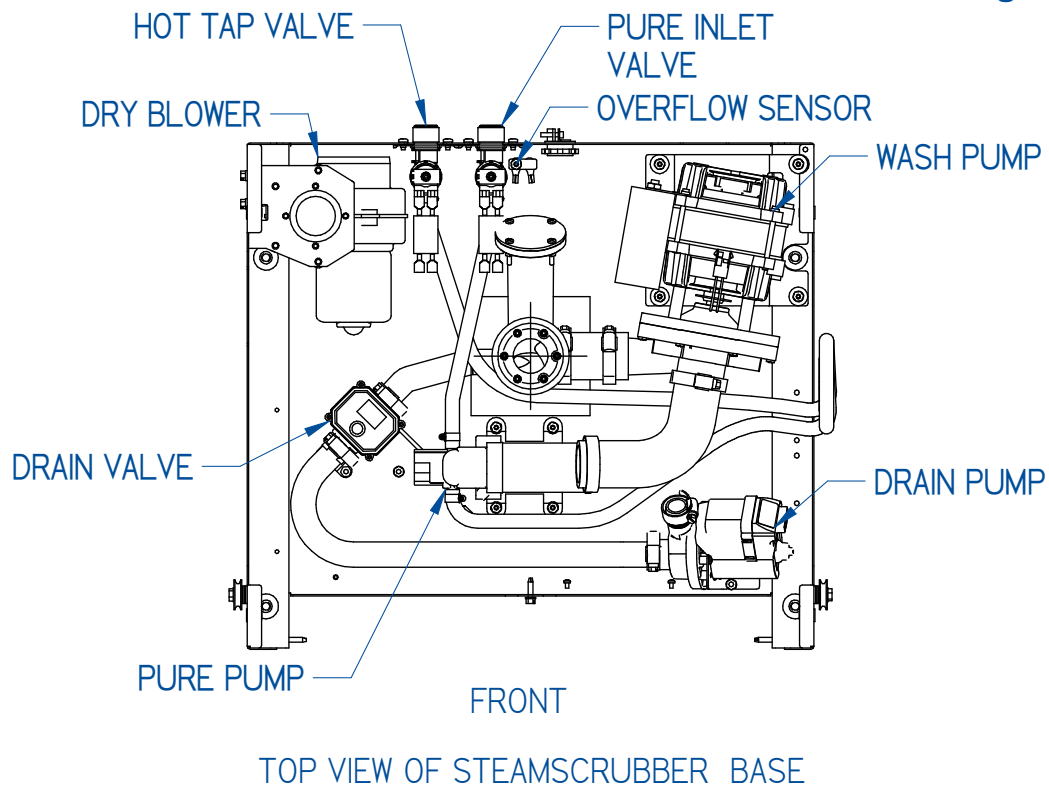

- Dry Blower: 12VDC, circulates air through the tank to dry labware after the rinse segment.
- Hot Tap Valve: 12VDC, electrically controlled to allow hot tap water to enter the tank.
- Pure Inlet Valve: 12VDC, electrically controlled to allow pure water to enter the tank.
- Overflow Sensor: This sensor is a set of contacts that when wet, have continuity signaling there is water in the base pan.
- Wash Pump: AC pump to circulate wash or rinse water through the wash arms and spindle racks if equipped.
- Drain Pump: AC pump to drain water from tank after the wash and rinse segments. Works in conjunction with Drain Valve.

- Pure Pump: 12VDC pump to pump from an unpressurized pure water source. Not required when adequate pressurized pure water source is available.
- Drain Valve: AC solenoid valve to drain water from tank after the wash and rinse segments. Works in conjunction with Drain Pump.

Removing the Toe Kick Panels, Service Panels and Door Assembly

For some maintenance and repair jobs associated with the FlaskScrubber and/or SteamScrubber, the toe kick and side panels will need to be removed to access the internal components. Refer to Figure 8-2 to see how the door and toe kick panels are assembled. Figure 8-3 also shows the sides and top panels on FlaskScrubber Vantage models.

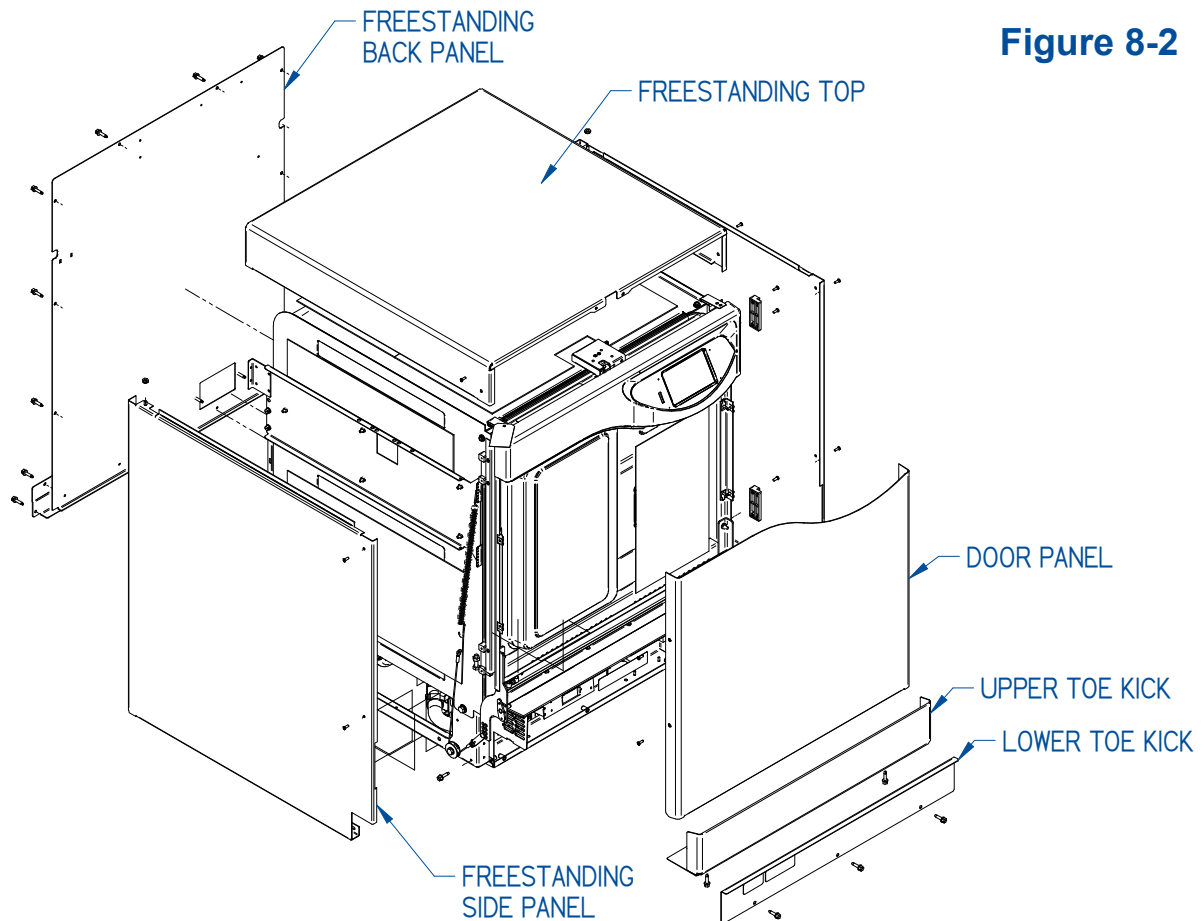
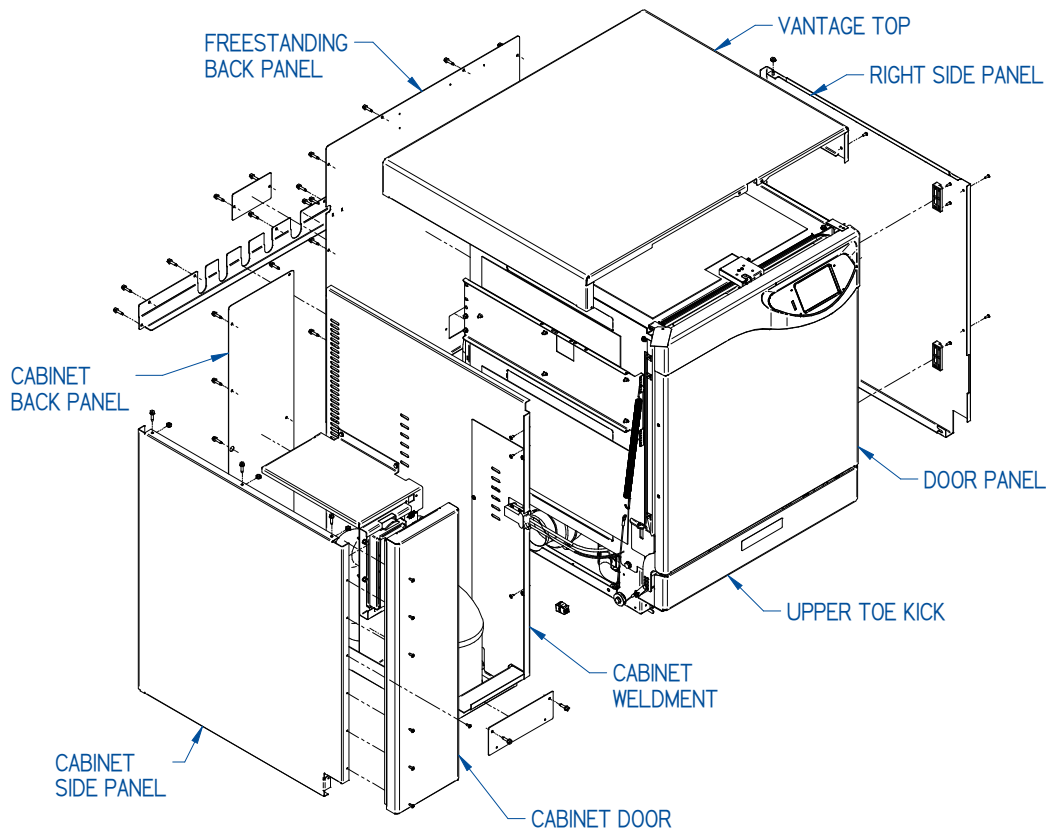

Figure 8-2

Figure 8-3



The undercounter units have individual panels covering the access opening on each side and the back of the base.

Remove the Door Panels and Toe Kick Panels

- Turn off electrical power to the glassware washer.
- Remove the three screws located across the bottom of the lower toe kick panel and remove panel.
- Remove two screws located at the bottom of each end of the upper panel, unplug the cooling fan and remove panel. Removing the upper toe kick panel will expose the electrical enclosure/junction box.
- Remove the two screws on each side of the front door panel and slide the panel down to disengage with the control panel to remove.

Removing the Back and Side Service Panels (Undercounter Models)

- Turn off electrical power to the glassware washer.
- Locate the back and side service panels attached to the base, under the insulation of the Undercounter Models. There are two screws holding each panel on. Simply remove the screws and pull off the plates. When replacing the plates, make sure they are properly aligned and in the correct orientation on the machine.

Removing the Washer Top, Back, and Side Panels (Free-Standing Models)

- Turn off electrical power to the glassware washer
- Refer to the Fig 8-2 and follow the instructions to remove the top, back, and side panels of your freestanding washer.
- To remove the back panel, remove all the screws from the back panel and remove the back panel.
- To remove the sides, loosen the two screws that hold the side panels to the base at the lower front on each side.
- Remove the two screws at the rear that hold the sides to the top.
- Remove the two screws on each side that hold the panels to the tank at the front edge.
- Remove the two screws that hold the panels to the tank in the back on each side.
- Remove the side panels by sliding forward and then down.
- To remove the top, remove the screws on each side near the front that hold the top to the tank.
- Remove the top by sliding forward then lifting up and off.

Removing the Door Assembly

- Turn off electrical power to the glassware washer.
- Follow the instructions above to remove the front door and toe kick panels.
- Follow the instructions above to remove the side panels of your freestanding washer.
- With the door closed and latched pull down on each door spring to remove the door cable from the door pulley. See Figure 8-5, Detail D. Note the hole position of the cable pin at the end that connects to the door and remove the cable linkage
- Remove the wire clamps securing the two door wires to the tank at the lower left-hand corner.
- Unplug the two door wires at the back side of the electrical enclosure.
- Carefully unlatch and open the door. Caution: with no springs for counterbalance the door will fall open without support.

- Lift the door off the hinge pin bracket by lifting up and out.
- Reverse this procedure to reinstall the door assembly.

Replacing or Adjusting the Door Latch, Latch Striker, Hinge Pins

If, when the door is closed and latched, the latch is loose, or the door is not sealing properly you may need to adjust the Door Latch or the hinge pin location. The door latch can be adjusted by either moving the latch or moving the striker. The latch may be accessed at the top of the wash tank. To access the latch the top panel will need to be removed on any freestanding unit. Refer to Fig 8-4. The hinge pins should only be adjusted if adjusting the latch does not provide the proper seal.

Adjusting the Striker

The nuts securing the striker are located behind the control panel. They can be accessed using a long flexible 3/8" nut-driver but are best accessed by removing the plastic control panel at the top of the door by removing the 7 screws that secure it to the inner door panel.

- To tighten the door seal by adjusting the striker, loosen the two #10-24 nuts that secure the striker to the inner door.
- Move the striker away from the latch. This usually requires a slight adjustment, too much will make the door hard to latch.
- Retighten the nuts.
- Test the latch.
- Repeat as needed.

Replacing or Adjusting the Latch Assembly

The nuts securing the Latch Assembly are located on the outside top of the wash tank. To access the lock assembly on Freestanding models the top panel will need to be removed.

- To replace the latch simply remove the three #8-32 nuts that secure the latch assembly to the top of the tank, unplug the harness, and replace latch to the forward most position, test the door seal and adjust as required.
- To tighten the door seal by adjusting the latch, loosen the three #8-32 nuts that secure the latch assembly to the top of the tank.
- Move the latch away from the striker. This usually requires only a slight adjustment, too much will make the door hard to latch.
- Retighten the nuts.
- Test the latch.

- Repeat as needed.

Figure 8-4

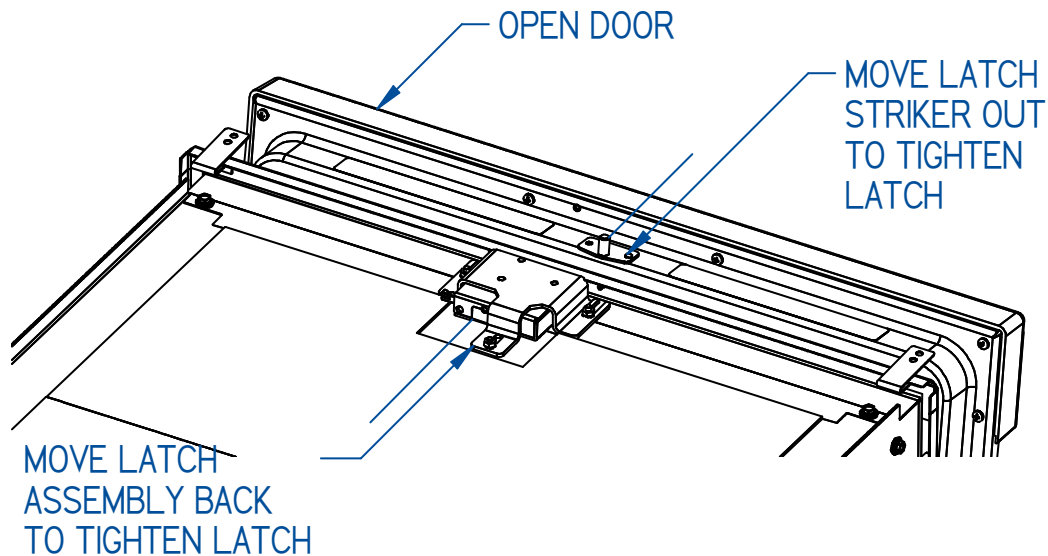

Adjusting the Door Hinge Pins

If the door is not seated properly against the door seal or is difficult to close after adjusting the latch, the hinge pins can be moved to achieve a better seal or to reduce some of the excess pressure of the door against the door seal. The door hinge pins are best accessed by removing the front door panel. Refer to Figure 8-5.

- To adjust the hinge pins, using a 1/8" hex wrench, loosen the four #10-24 Button Head Cap Screws that secure the hinge pin weldment to the bottom of door assembly.
- Rotate the top of the hinge pin weldments toward the unit to loosen the door seal. Rotate the weldment away from the washer to tighten the seal.
- Once both hinge pins are adjusted tighten the four #10 Button Head Cap Screws to secure the hinge pin location.
- Test the latch and the door seal by running a short rinse cycle.
- Repeat hinge pin or the latch adjustment as needed.
- Moving the hinge pins can affect the door level when open. Once the door seal and latch are working properly check the level of the door when open.
- Adjust the door stops as needed.

Figure 8-5

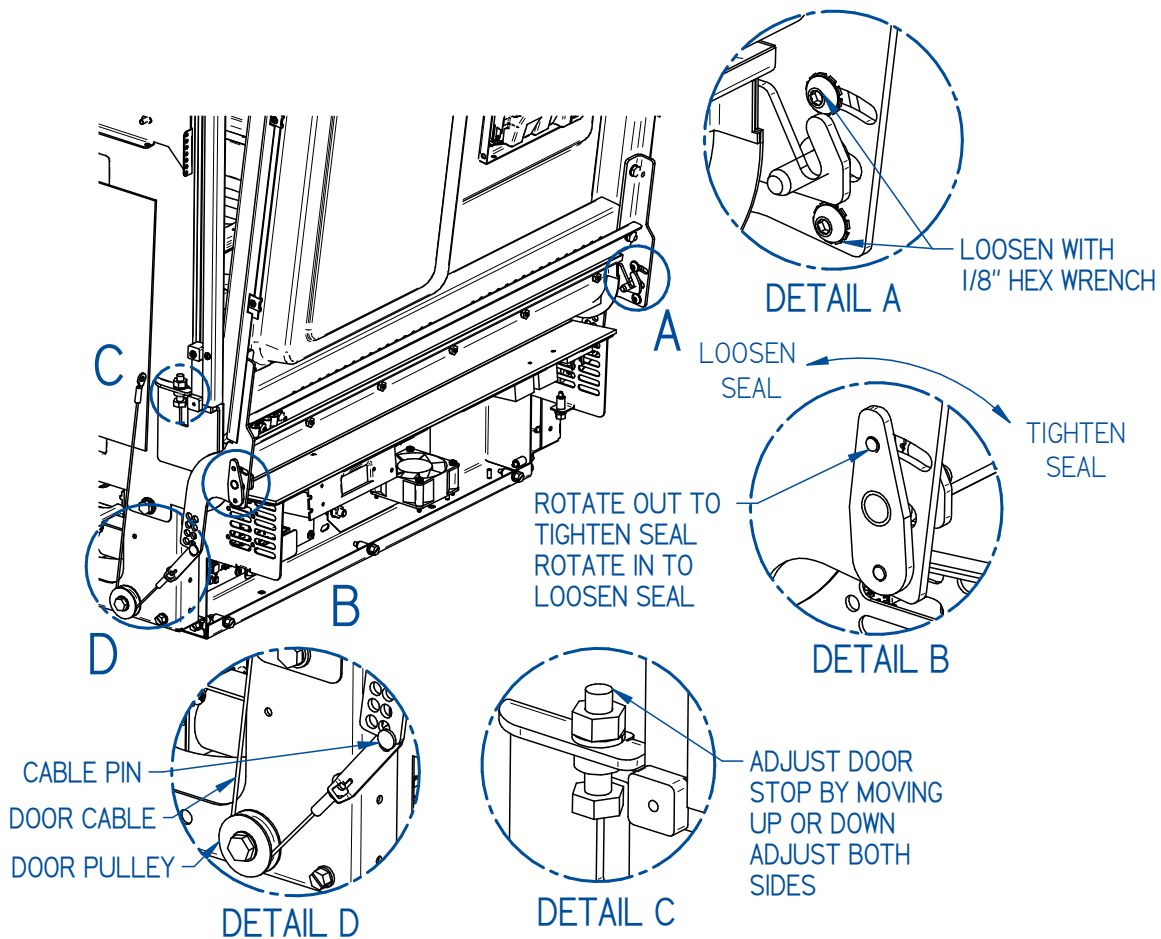

Door Gasket Replacement

If, after adjusting the door latch and hinge pins, the door is still not sealing properly the door gasket may need to be replaced. Before the door gasket can be removed and replaced the washer's door must be removed as described in the section above Removing the Toe/Kick Panels, Service Panels and Door Assembly.

- Disconnect power to the unit.
- Remove the door assembly. Refer to Removing Door Assembly Instructions above.
- Taking note of the gasket's seal flap orientation. Remove the bad/damaged gasket by pulling it from its channel around the outer edge of the tank.
- The replacement rubber gasket will be cut longer than necessary.
- Starting on one side, with the sealing flap in the proper orientation, place one end of the gasket where it is touching the bottom of the wash tank. Push the new

gasket firmly into place into the channel up one side, across the top and then down the other side. You can wet the gasket to assist in pressing into place.

- When the bottom of the second side is reached, the gasket will need to be trimmed so that the new end rests snugly against the bottom of the tank.

Replacing the Washer LED Light

If the Glassware Washer has a window it is equipped with an LED light. If the light is not working confirm the light is turned on by looking at the Accessories Tab. The LED can be turned ON or OFF on this page. If ON, the operation of the LED can be tested in Diagnostic. Should you need to replace the LED light strip, refer to Figure 8-6, and follow the instructions below.

- Disconnect power to the unit.
- Remove the front door panel.
- The light strip is mounted to the bottom of the window retainer bracket. Using a razor knife cut the pressure sensitive adhesive (PSA) that secures the light strip to the window retainer bracket. A flat bladed screwdriver can be used to pry the light away from the bracket.
- Carefully remove the wires connected to the light by firmly grasping each wire terminal, one at a time, with a pair of pliers and rotating while pulling out. Do not pull by the wires. Take note which wire goes to which terminal.
- Cut and clean any remaining tape or adhesive from the window retaining bracket.
- Plug the two wires into the new LED Light Strip, the red wire should be connected to the positive terminal which will be identified by a dot on the board next to the terminal.
- Remove the protective paper from the PSA on the back side of the light and place the light back on the door retainer bracket.
- Reassemble the door.
- Reconnect power to the unit, confirm the light is turned ON in Accessories and test the light in diagnostics.

Figure 8-6

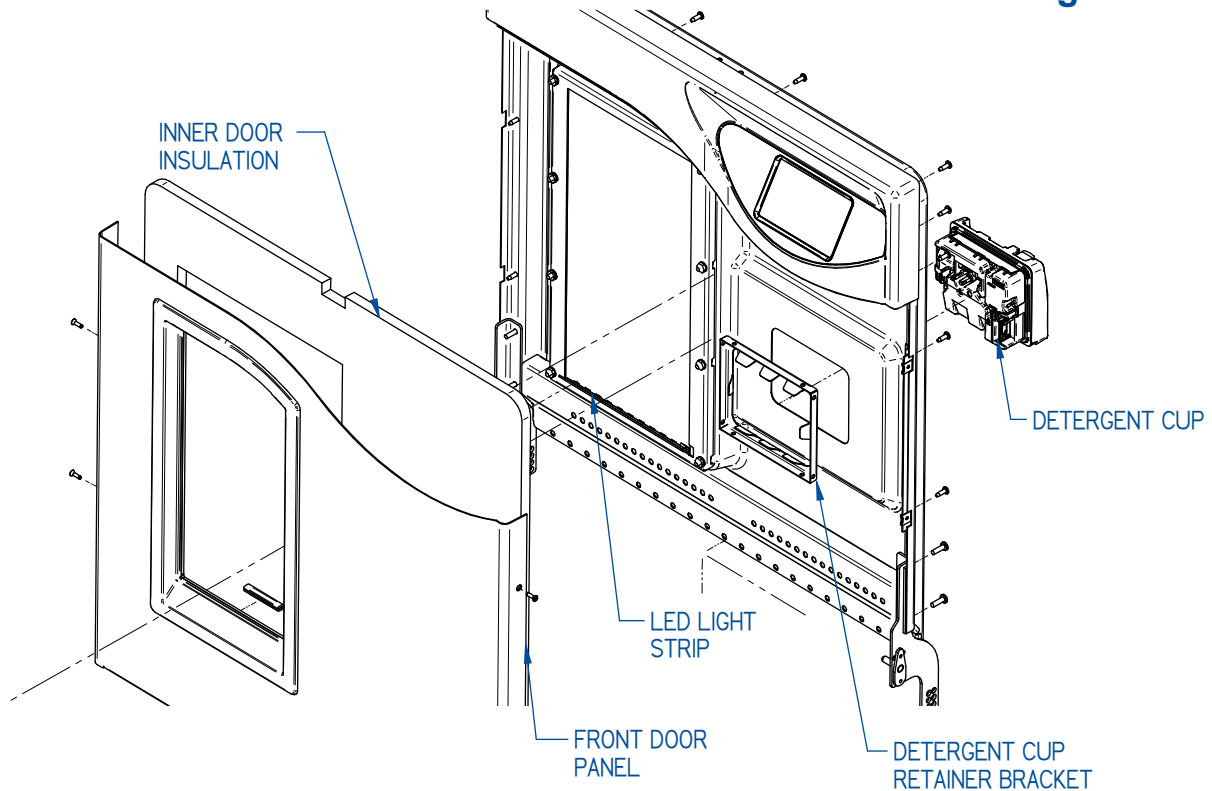

Replacing the Detergent and Acid Rinse Dispenser

All Glassware Washers are equipped with a Detergent and Acid Rinse Dispense Cup in the door. The operation of the Detergent Cup can be tested in Diagnostic. Should it need replacing refer to Figure 8-6 and follow the instructions below. Note: It is recommended that the Detergent Cup Retaining Bracket be replaced any time the detergent Cup is replaced.

- Disconnect power to the unit.
- Remove the front door panel.
- Remove or raise the inner door insulation away from the Detergent Cup
- Disconnect the two RAST wire connectors from the back side the Detergent Cup.
- Note which wires go to which connection.
- The detergent cup is held in place by the metal tabs of the detergent cup retaining bracket. The tabs snap under a series of stepped notched in the back of the detergent cup. To remove the bracket, use a flat screwdriver to pry the tabs of the retainer bracket out while pressing in on the detergent cup. Work your way

around to each tab and bend them out far enough to clear the notches. Once the tabs are bent out the Detergent cup can be pushed away from the door.

- Clean the sealing surface on the inner door panel.
- Place the new detergent cup in the door cutout in the same orientation as the old one. Make sure the edge of the gasket fits down in the cutout all the way around the perimeter of the opening. The flat portion of the gasket must rest snugly against the face of the inner door.
- While holding the detergent cup in place from the tank side of the door, place the retaining bracket over the detergent cup on the outside of the door.
- Firmly press the bracket towards the door panel until the tabs of the bracket snap over the stepped notches on the detergent cup to hold it in place. Press in place as firmly and evenly as possible.
- Make sure the flat portion of the gasket is seated properly against the inner door panel. Support the detergent cup on the tank side of the door. Use a flat bladed screwdriver to press the base of each tab to snap the tabs down the notches as far as possible. This tightens the seal against the inner door panel.
- Replace the wires removed previously. Black and white to the right, blue and green to the left.
- Replace the insulation and front door panel.
- Reconnect power to the unit, confirm proper operation by closing the detergent cup and testing in diagnostics.
- Check the seal for leaks by running a short cycle.

Replacing the Electronic Control Components

Display Board Assembly includes the Android touch screen and Beagle Bone Board (BBB) that is the interface between the user and the main Input Output Board (IOB). The IOB houses the logic and controls the timing of all the electronic components. Use the procedures below to access and replace the Display Board Assembly and IOB as required.

Replacing the Display Board Assembly

Should you need to replace the Display board Assembly refer to Figure 8-7 and follow the instructions below.

- Turn off electrical power to the glassware washer.
- Remove the front door panel by removing the two screws on each side of the door.
- Open the door to remove the mounting screws on the backside that secures the gray plastic control panel.

- Pull the Control Panel away from the door to access the display board assembly cover plate.
- Remove the six screws that secure the cover plate to the plastic control panel.
- Carefully remove the cover plate and gasket taking note of the routing and location of the wiring and wiring connections.
- Remove the four phillips screws securing the display board assembly to the plastic control panel.

Figure 8-7

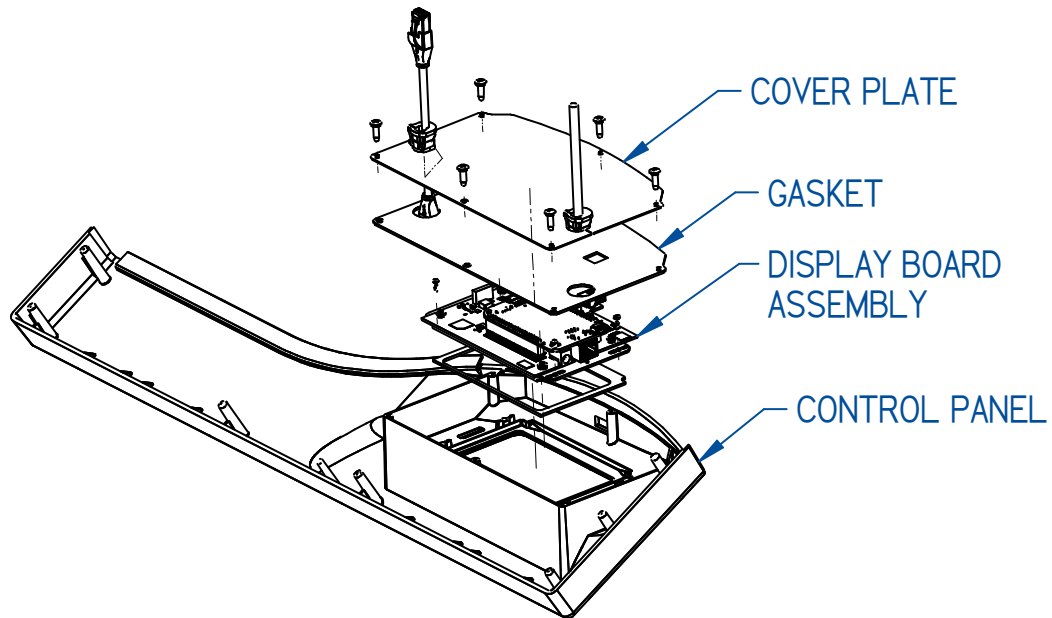

- Unplug the wiring and remove the display board.
- Remove the protective plastic film from the replacement display board.
- Set the new display back in the plastic control panel and secure using the four screws removed in the previous step.
- Reconnect the wiring as shown in Figure 8-8.

Figure 8-8

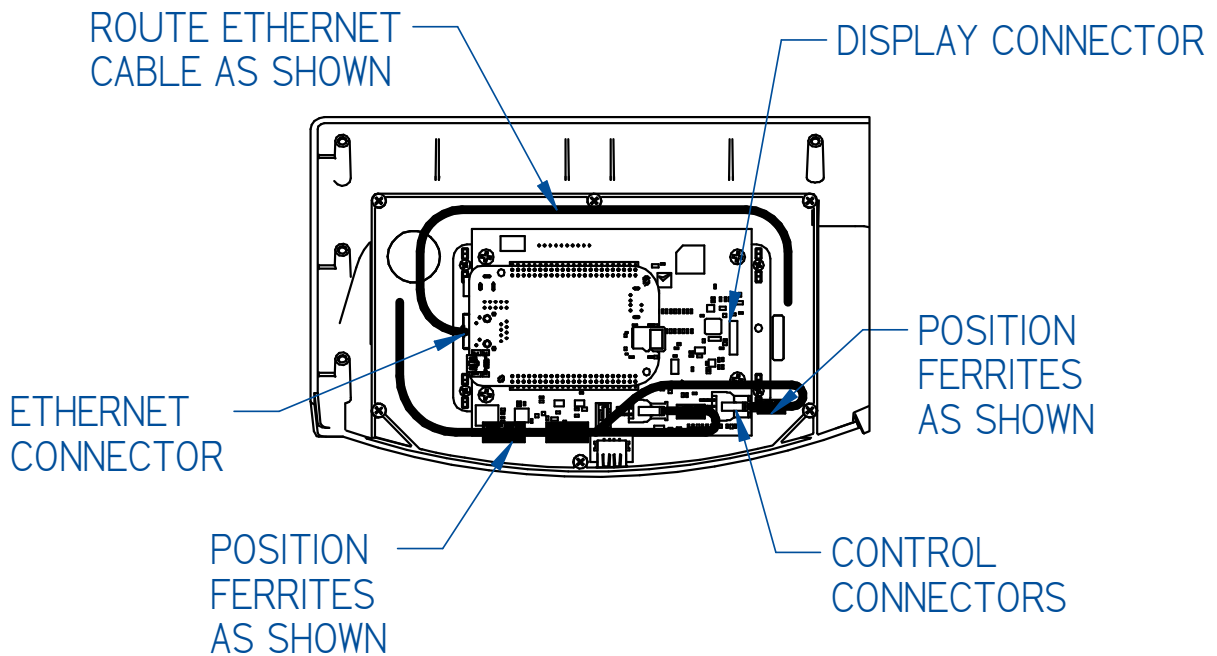

- Route the wires and place the ferrites approximately as shown before replacing the gasket and cover plate.
- Reassemble the control panel and front door panel.
- Reconnect power to the unit.
- Upload the latest software as described in Chapter 4.

Replacing the Input/Output Board (IOB)

Should you need to replace the Input Out Board refer to Figure 8-9 and follow the instructions below.

- Turn off electrical power to the glassware washer.
- Remove the toe kick panels as detailed with Figure 8-2.
- Remove the #10-24 hex head screw located approximately in the center of the electrical enclosure.
- Loosen the two screws at the bottom on each side of the enclosure.
- Pull the electrical enclosure out to access the wire connections on the back side.
Note: on early models the wiring harness located on the back righthand side of the electrical enclosure will need to disconnect to pull the enclosure away from

the base. This connection is best accessed from the right side of the washer base and will require removal of the right-side panel on Freestanding units.

- Unplug all the wires connected to the front and back side of the IOB.
- Remove the six screws holding the IOB to the electrical enclosure. Note: on early models the power supply will need to be removed to access one of the screws in the IOB. Refer to the instructions for Removing the Power supply below.
- Install the new IOB.
- Reconnect all the wiring connections. Note: the 4-pin connector with red, black and green wires is for factory testing and will not be used.
- Replace and secure the enclosure to the base.
- Reinstall the toe kick remembering to plug the cooling fan back in.
- Reconnect power to the unit.
- Install the latest software as detailed in Chapter 4.

Figure 8-9

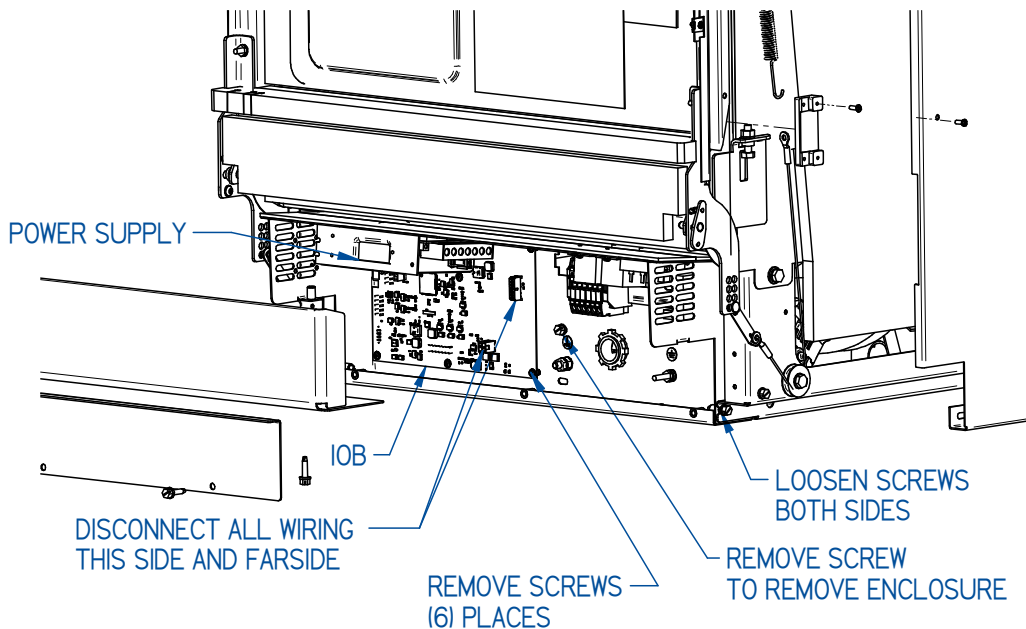

Replacing the Power Supply

Should you need to replace the Power Supply refer to Figure 8-9 and follow the instructions below.

- Turn off electrical power to the glassware washer.
- Remove the toe kick panels as detailed with Figure 8-2.

- Remove the #10-24 hex head screw located approximately in the center of the electrical enclosure.
- Loosen the two screws at the bottom on each side of the enclosure.
- Pull the electrical enclosure out to access the wire connections on the back side.
Note: on early models the wiring harness located on the back righthand side of the electrical enclosure will need to be disconnected to pull the enclosure away from the base. This connection is best accessed from the right side of the washer base and will require removal of the right-side panel on Freestanding units.
- Remove the two screws that secure the power supply to the electrical Enclosure located under the insulation on the top side of the enclosure.
- Remove the wiring of the power supply taking note of the position of each connection.
- Reconnect the wires to the new power supply and secure it to the enclosure.
- Replace and secure the enclosure to the base.
- Reinstall the toe kick remembering to plug the cooling fan back in.
- Reconnect power to the unit.
-

Replacing Electronic Enclosure Components

Should you need to replace the any of the other components found in the electrical enclosure refer to Figure 8-10 to determine location and follow the instructions below.

- Turn off electrical power to the glassware washer
- Remove the toe kick panels as detailed with Figure 8-2.
- Remove the target component as shown in Figure 8-10.
- Note: remove relays as required to access the fasteners that secure the Heater 1 Triac.
- Unplug the wires from the old part.
- Plug in the wires to the new part.
- Fasten the new part to the enclosure.
- Reinstall the toe kick remembering to plug the cooling fan back in.
- Reconnect power to the unit.

Figure 8-10

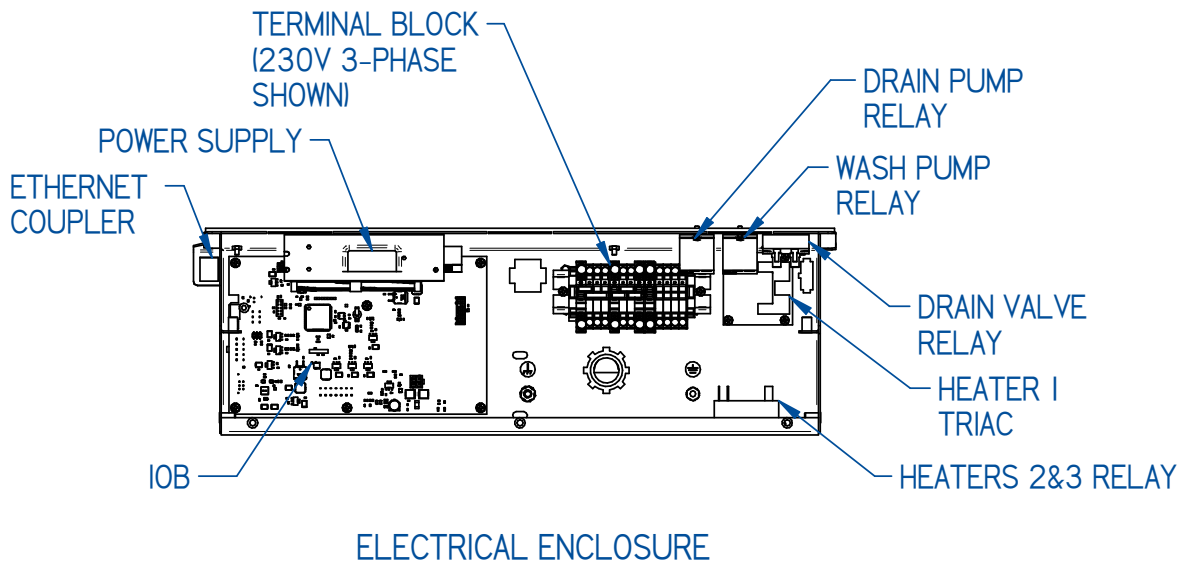

Replacing Water Level Pressure Switch(Prior to 8/23, cat. # rev J)

The water level pressure switch monitors the water level to determine when the fill is complete to turn the water inlet valve off. The sensor will also set the High-water Alarm should the water level get too high. Should you need to replace the Water level Pressure Switch refer to Figure 8-11 and follow the instructions below.

If your washer has the pressure switch, upgrade the washer to the sensor type. Use kit part number 4687310. Follow the instructions included in the kit.

- Turn off electrical power to the glassware washer.
- If the washer is a freestanding model remove the back panel as detailed with Figure 8-2.
- Cut the tape at both back corners of the insulation blanket to raise the blanket to expose the pressure sensor assembly.
- Remove the two nuts securing the sensor assembly to the tank as shown in Figure 8-11.
- Disconnect the wiring.
- Loosen the hose clamp and remove the assembly from the ½” diameter tube.
- Reverse this procedure to install the switch.
- Reconnect power to the unit.

- Once power is restored the switch must be calibrated to set the correct water level as described with Figure 4-18 and 4-19, in Chapter 4.

Figure 8-11

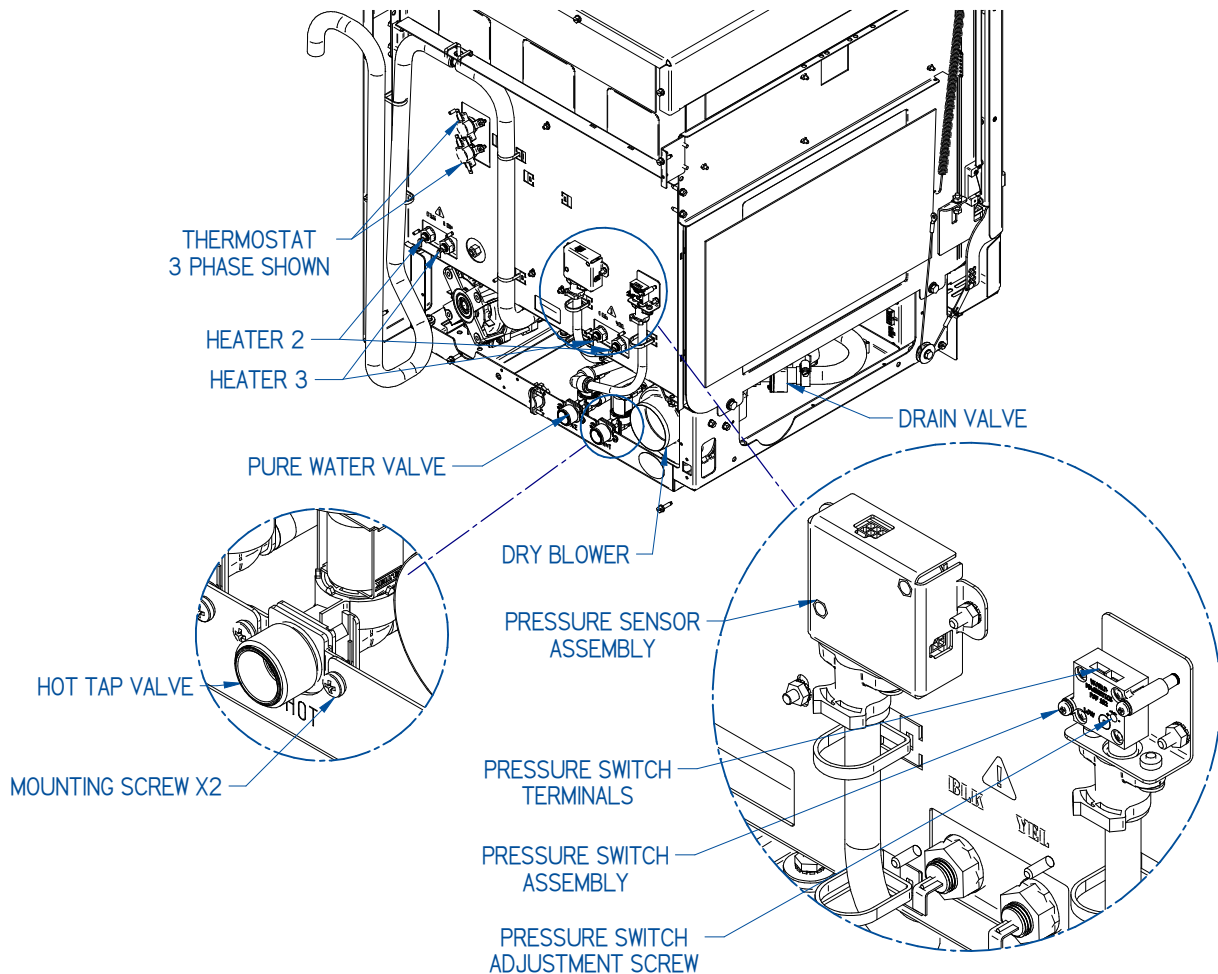

Replacing Overfill Water Level Sensor(After 9/23 cat. # rev. P)

The Water Level Pressure Sensor will actuate to turn off power to the inlet valve should the washer continue to fill over the normal set point.

The included wire assembly, 4674501, does not need to be installed unless the connector to the sensor is damaged!

Uninstall the Overflow Sensor:

1. Disconnect power to the glassware washer.
2. Mark the location of the Overflow Sensor so the new sensor can go back at the same location.
3. Remove the Overflow Sensor assembly by removing the screw and nut on the sensor holder.
4. Disconnect the connector by pushing in on the detent on the connector and pull on the connector (**Do not pull on the wires!**).

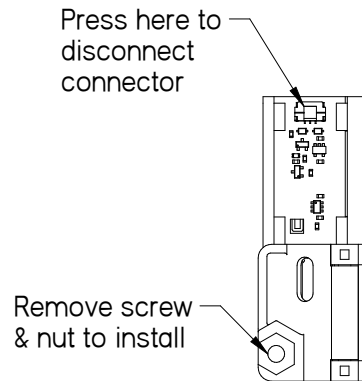

Install the Overflow Sensor:

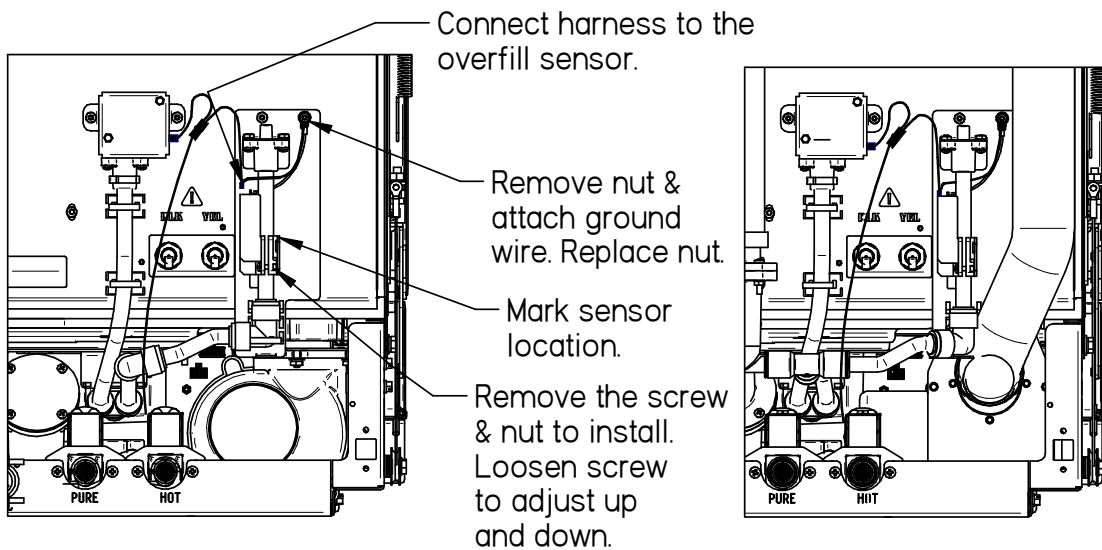

SteamScrubber

FlaskScrubber

1. Connect the wire assembly connector to the new Overfill Sensor. If the connector is damaged, use the supplied wire assembly.
2. Install the new Overfill Sensor in the same location with the screw and nut. Pass the green ground wire behind the tube.
3. Remove the nut that holds the Overfill Sensor mounting bracket and connect the green ground wire. Replace the nut.

Set Overfill Sensor:

7. Turn the power back on
8. Go to the Maintenance Screen, and touch for 2 to 5 seconds the top and bottom left corners of the display simultaneously to get to the Factory Settings page.
9. Perform a factory fill. Once completed change the fill time to 5 and continue to fill the tank. Continue filling the tank. You will receive the High Water Alarm. Keep filling until the water level touches the baffle retainer on the front of the washer. Turn off the water immediately by pressing the "OK" and "STOP FILL" buttons on the display.
10. Check the water level in the tank. The water level should be just touching the baffle retainer. The blue light on the overfill sensor should be on.
 - a. If the water level didn't reach the baffle retainer, the sensor should be moved up. Add water until it reaches the baffle retainer and the blue light turns on.
 - b. If the blue light is not on, the sensor should be moved down.
11. Raise the sensor up 1/8" above this until the light goes off. Tighten the screw (do not overtighten).

12. Drain the water and repeat step 4 to confirm that the Overfill Sensor is set correctly. **Caution:** *In the Factory Fill Screen only, you can continue to add water over the High Water Alarm until the Overfill Sensor actuates. If the Overfill Sensor is set too low, you will never get the High Water Alarm. If the Overfill Sensor is set too high and never actuates you can continue to add water and over run the tank.*

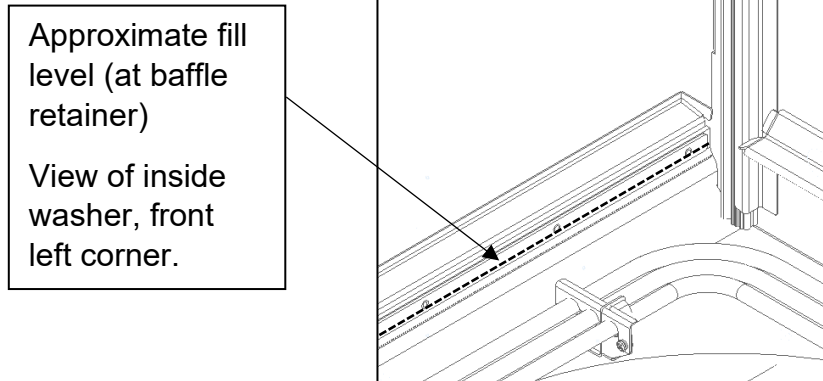

Replacing Heating Elements

All single-phase models have one heating element (Heater 1) used to heat the water during the wash, rinse, and dry segments. In addition to Heater 1, all three phase units have two additional 2000-watt elements (Heaters 2&3) used to heat the water during the wash and rinse cycles. Heater 1 is used to heat the forced air during the dry cycle. Should you need to replace any of the heating elements refer to Figure 8-12 and follow the instructions. Note: when replacing any of the heating elements the sealing washers (PN 1924402) should also be replaced.

Replacing Heater 1

Heater 1 terminals are located under the wash tank on the right-hand side of the base.

- Turn off electrical power to the glassware washer.
- If the washer is a freestanding model, remove the back and right-side panels as detailed with Figure 8-2.
- Cut the tape at the back corner of the insulation blanket to raise the blanket to expose the right side of the base.

- If the washer is an undercounter model remove the sheet metal access panel mounted to the right side of the base.
- Disconnect the 2 wires connected to the heater terminals.
- Remove the two nuts securing the heater terminals to the wash tank.
- Open the door and from inside the wash tank, if the optional heater cover is installed remove the four thumb screw securing it and remove the covers.
- Loosen the mounting bracket clamps securing the heater.
- Remove the heater.
- Reverse this procedure to install the new heater. Remember the sealing washers.
- Reconnect power to the unit.

Replacing Heater 2&3

Heater 2&3 terminals are located at the back of the wash tank as shown in Figure 8-12.

- Turn off electrical power to the glassware washer.
- If the washer is a freestanding model, remove the back panel as detailed with Figure 8-2.
- Cut the tape at the back corners of the insulation blanket to raise the blanket and expose the back of the tank.
- If the washer is an undercounter model remove the sheet metal brackets that cover the heater terminals.
- Disconnect the wires from the heater you are wanting to replace. Heater 2 terminals are the two outside terminals with black 15B wire and yellow 16 wire. Heater 3 terminals are the two inside with black 17 wire and red 11B wire.
- Remove the two nuts securing the heater terminals to the wash tank.
- Open the door and from inside the wash tank loosen the five mounting bracket clamps securing the heaters as shown in Figure 8-12.
- Remove the heater.
- Reverse this procedure to install the new heater. Remember the sealing washers.
- Reconnect power to the unit.

Figure 8-12

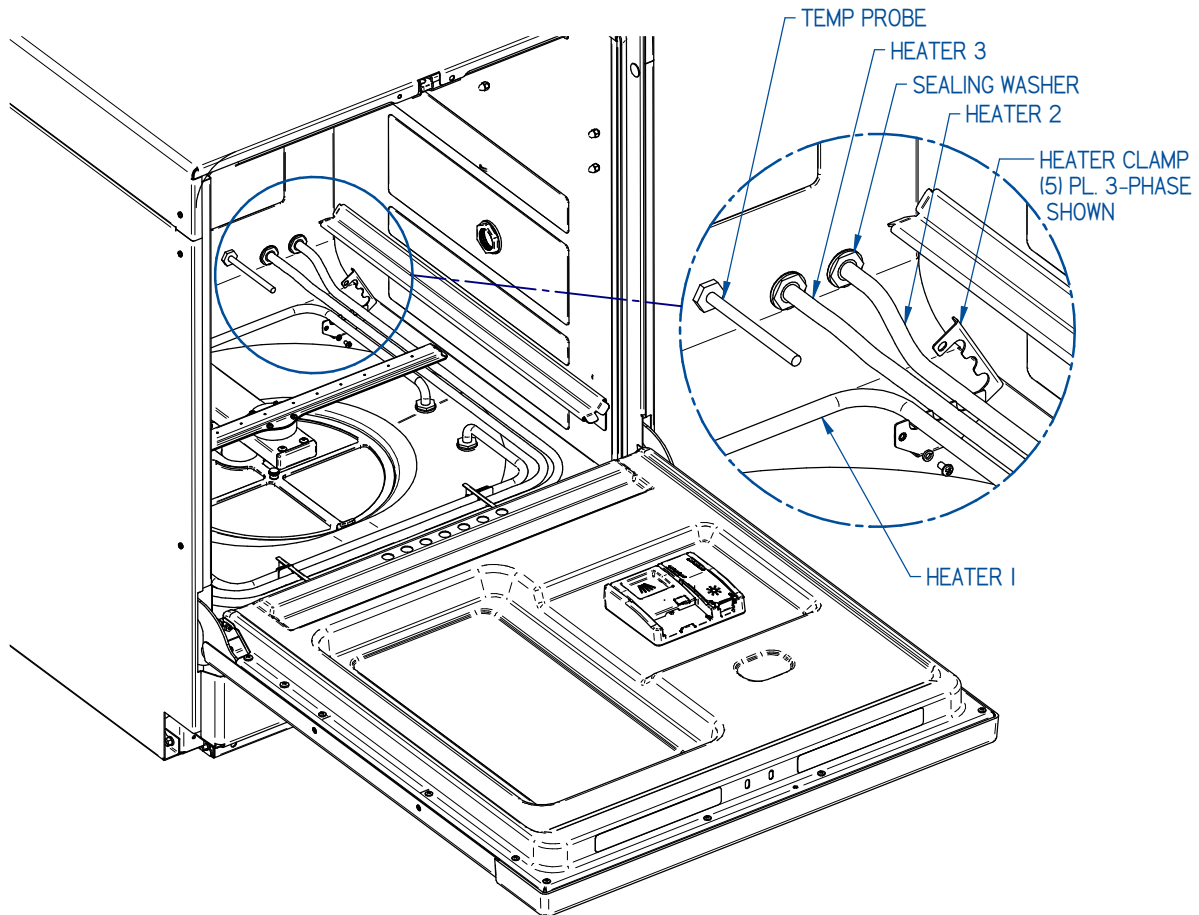

Replacing Pumps

All glassware washers are equipped with three pumps. The wash pump, and drain pumps are both AC, the pure water pump is rated 12VDC. The pure water pump can be turned off if the pure water supply is pressurized so if the pure water pump is not working, confirm that it is turned on by checking the Accessories Screen. Should you need to replace any of the pumps refer to the following instructions.

Replacing Wash Pump

The wash pump is located at the back right-hand corner of the base. To provide the room needed to remove the wash pump assembly the tank will need to be separated and raised from the base at the back. Refer to Figure 8-13.

- Completely drain and disconnect electrical power to the unit.
- If the washer is a freestanding model, remove the back and side panels as detailed with Figure 8-2.
- Cut the tape at the back corners of the insulation blanket and raise the blanket to expose the back and sides of the tank.
- If the washer is an undercounter model remove the sheet metal brackets that cover the heater terminals and the sheet metal access panels mounted to the right side and back of the base.
- Unplug the wires from the wash pump.
- Loosen the clamps holding the two hoses to the pump connections and remove the hose from the pump inlet. Refer to Figure 8-1.
- Remove the four nuts that hold the motor's mounting bracket to the base weldment.

Figure 8-13

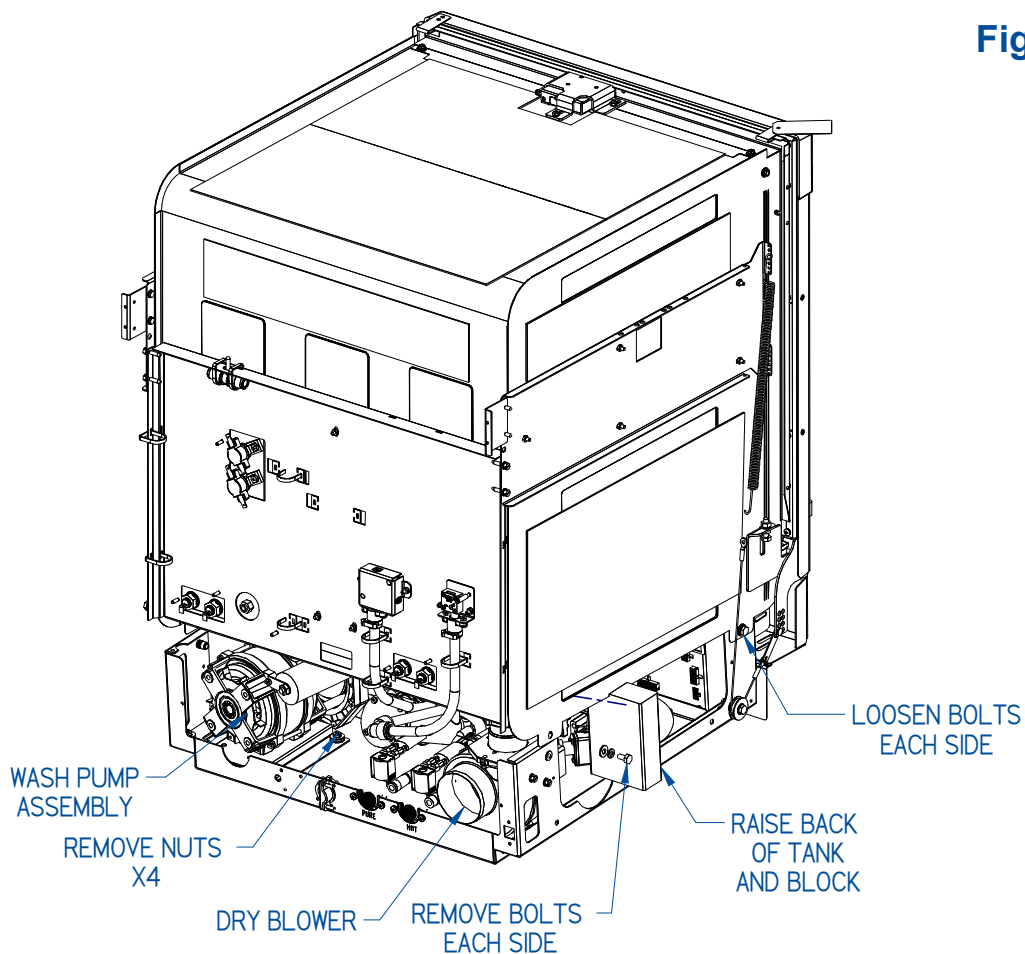

- Remove the two bolts that secure the tank to the base on each side at the back. Loosen the two bolts that secure the tank to the base on each side, near the front. These bolts will be used as a pivot point when raising the back of the tank.
- Raise and securely support the back of the tank enough to provide the clearance needed to lift the wash pump assembly off the mounting studs away from the outlet hose and out the back of the base.
- Remove the pump mounting bracket and place it on the new pump.
- Reverse this procedure to install the new pump. Remember to tighten the hose clamps.
- Reconnect power to the unit.

Replacing the Wash Pump on a FlaskScrubber Vantage

The wash pump is mounted to the back right floor of the base weldment. To provide the room needed to remove the blower assembly the tank will need to be separated from the base and raised at the back. To accomplish this the stainless-steel side panels and side car will need to be removed from the Vantage tank/base assembly. Refer to Figure 8-3 to see how the cabinet is assembled. Once the cabinet has been removed follow the instructions for Replacing the Wash Pump above.

Replacing the Pure Water Pump

The Pure pump is located at the center of the base behind the electrical box and under the sump. To provide the room needed to remove this pump the electrical enclosure will need to be removed. Refer to Figure 8-9.

- Turn off electrical power to the glassware washer.
- Remove the toe kick panels as detailed with figure 8-2.
- Remove the #10-24 hex head screw located approximately in the center of the electrical enclosure.
- Loosen the two screws at the bottom on each side of the enclosure.
- Pull the electrical enclosure out to access the wire connections on the back side. Note: on early models the wiring harness located on the back righthand side of the electrical enclosure will need to be disconnected to pull the enclosure away from the base. This connection is best accessed from the right side of the washer base and will require removal of the right-side panel on Freestanding units.
- Disconnect the wiring from the back side of the electrical enclosure and remove the enclosure.
- Unplug the pump.
- Loosen the hose clamps and remove the inlet and outlet hoses from the pump.
- Remove the four nuts securing the pure pump to the base weldment.
- Lift the pump off the base studs and remove.

- Reverse this procedure to install the new pump. Remember to tighten the hose clamps.
- Reconnect power to the unit.

Replacing the Drain Pump

The Drain Pump Assembly is located on the right side of the base behind the electrical enclosure. Refer to figure 8-1. To provide the room needed to remove this pump it is best to pull the electrical enclosure away from the base.

- Turn off electrical power to the glassware washer
- Remove the toe kick panels and right-side panel as detailed with figure 8-2.
- Remove the #10-24 hex head screw located approximately in the center of the electrical enclosure.
- Loosen the two screws at the bottom on each side of the enclosure.
- Pull the electrical enclosure out enough to access the pump. Note: on early models the wiring harness located on the back righthand side of the electrical enclosure will need to be disconnected to pull the enclosure away from the base. This connection is best accessed from the right side of the washer base.
- Disconnect all the wiring from the back side of the electrical enclosure if you wish to remove the enclosure completely.
- Unplug the pump.
- Loosen the hose clamps and remove the inlet and outlet hoses from the pump.
- Remove the two nuts securing the drain pump assembly to the base weldment.
- Lift the pump off the base studs and remove.
- Reverse this procedure to install the new pump. Remember to tighten the hose clamps.
- Reconnect power to the unit.

Replacing the Vantage Detergent and Rinse Aid Pumps

The automatic detergent and rinse aid pumps are mounted to the floor of the side cabinet near the back. They can be accessed by removing the cabinets back panel.

- Disconnect electrical power to the unit.
- Remove the back panel of the side cabinet.
- Remove the two nuts that secure the pump to the cabinet base. The larger pump is for detergent the smaller pump is for rinse aid.
- Disconnect the wiring harness.

- Use Caution: The Detergent is caustic, and Rinse Aid is acidic, if there is liquid in the tubing you will want a way to catch it as it runs out after disconnecting the tubing.
- Disconnect the inlet and outlet tubing at the barb connector fittings.
- Reverse this procedure to install the new pump.
- Reconnect power to the unit.
- Remember to purge the air from the system by running the pump in diagnostics.

Replacing Valves

All glassware washers are equipped with three valves. The Hot Tap and Pure Water inlet valves are both 12VDC, the drain valve is AC. Before replacing either of the inlet valves for low water conditions check for restrictions in the hoses and in the filter screen at the inlet of the valves. The pure water system can be turned off for applications where there is no pure water supply connected. If the pure water system is connected and not working, confirm that it is turned on by checking the Accessories Screen. Should you need to replace any of the valves refer to the following instructions.

Replacing Hot Tap or Pure Water Valves

The water inlet valves are mounted to the back panel of the base weldment marked HOT and PURE. Refer to Figure 8-11.

- Completely drain the water and disconnect electrical power to the unit.
- Turn the water supply connection off.
- Remove the back panel as detailed with Figure 8-2.
- Remove the water supply line from the valve inlet.
- Disconnect the wiring harness from the valve.
- Remove screws that secure the inlet valve to the base. Refer to figure 8-11.
- Loosen the hose clamp and remove the outlet hoses from the valve.
- Reverse this procedure to install the new valve.
- Remember to tighten the hose clamps.
- Turn the water supply connection on and check for leaks
- Reconnect power to the unit.

Replacing Drain Valve

The drain valve is mounted on the left side of the base weldment.

- Completely drain and disconnect electrical power to the unit.
- Turn the water supply connection off.
- Remove the back and left-side panels as detailed with Figure 8-2.

- Remove the water supply line from the valve inlet.
- Disconnect the wiring harness from the valve.
- Remove the nut that secures the drain valve clamp to the base.
- Loosen the hose clamp end of the valve inlet hose nearest the sump.
- Loosen the hose clamp on the outlet of the valve and remove the outlet hose from the valve.
- Remove the valve and inlet hose together.
- Loosen the clamp and remove the inlet hose from the valve.
- Reverse this procedure to install the new valve.
- Remember to tighten the hose clamps.
- Reconnect power to the unit.

Replacing the Blower

All glassware washer models are equipped with an integrated blower for drying glassware at the end of a cycle. The SteamScrubber blower pushes air into the tank through the blower shroud (found in the rear left of the tank). The FlaskScrubber uses the water manifold and racks of the washer to circulate hot air that is directly injected into narrow neck glassware. The FlaskScrubber Vantage models use the same blower set up as the FlaskScrubber; however, the air fed to the blower is pulled through a HEPA filter before being circulated through the tank. Use the procedure below to replace the blower of the unit you are working on.

Replacing the Dry Blower on a SteamScrubber

The dry blower is mounted to the left rear side panel of the base weldment. To provide the room needed to remove the blower assembly, the tank will need to be separated from the base and raised at the back. Refer to Figure 8-13.

- Completely drain and disconnect electrical power to the unit.
- If the washer is a freestanding model, remove the back and side panels as detailed with Figure 8-2.
- Cut the tape at the back corners of the insulation blanket and raise the blanket to expose the back and sides of the tank.
- If the washer is an undercounter model remove the sheet metal brackets that cover the heater terminals and the sheet metal access panels mounted to the left side and back of the base.
- Unplug the wires from the dry blower.
- Remove the two screws that secure the blower assembly to the left side of the base weldment.
- Remove the two bolts that secure the tank to the base on each side at the back.

- Loosen the two bolts that secure the tank to the base on each side near the front. These bolts will be used as a pivot point when raising the back of the tank.
- Raise and securely support the back of the tank enough to provide the clearance needed to lift the dry blower assembly out the back of the base.
- Remove the blower mounting bracket and place it on the new blower.
- Reverse this procedure to install the blower assembly.
- Reconnect power to the unit.

Replacing the Dry Blower on a FlaskScrubber

The dry blower is mounted to the back left floor of the base weldment. To provide the room needed to remove the blower assembly, the tank will need to be separated from the base and raised at the back. Refer to Figure 8-13.

- Completely drain and disconnect electrical power to the unit.
- If the washer is a freestanding model, remove the back and side panels as detailed with Figure 8-2.
- Cut the tape at the back corners of the insulation blanket and raise the blanket to expose the back and sides of the tank.
- If the washer is an undercounter model remove the sheet metal brackets that cover the heater terminals and the sheet metal access panels mounted to the left side and back of the base.
- Unplug the wires from the dry blower.
- Remove the two nuts that secure the blower assembly to the left floor of the base weldment.
- At the back of the unit loosen the hose clamp and remove the hose connected to the outlet of the blower
- Remove the two bolts that secure the tank to the base on each side at the back.
- Loosen the two bolts that secure the tank to the base on each side near the front. These bolts will be used as a pivot point when raising the back of the tank.
- Raise and securely support the back of the tank enough to provide the clearance needed to lift the dry blower assembly out the back of the base.
- Remove the blower mounting bracket and place it on the new blower.
- Reverse this procedure to install the blower assembly.
- Reconnect power to the unit.

Replacing the Dry Blower on a FlaskScrubber Vantage

The dry blower is mounted to the back left floor of the base weldment. To provide the room needed to remove the blower assembly, the tank will need to be separated from

the base and raised at the back. To accomplish this the stainless-steel panels and side cabinet will need to be removed from the Vantage tank/base assembly. Refer to Figure 8-3 to see how the cabinet is assembled. Once the cabinet has been removed follow the instruction above for Replacing the Dry Blower on a FlaskScrubber.

Cleaning or Replacing the Wash Arms

All glassware washer models are equipped with lower and upper wash arms. The addition of the upper rack will add a third wash arm. You can check the operation of each wash arm simply by giving them a spin. The wash arms should spin freely, if you find they do not, a good cleaning or replacement of the plastic washers may be required. Should you need to clean or replace any of the components of the wash arms refer to the following instructions.

Figure 8-14

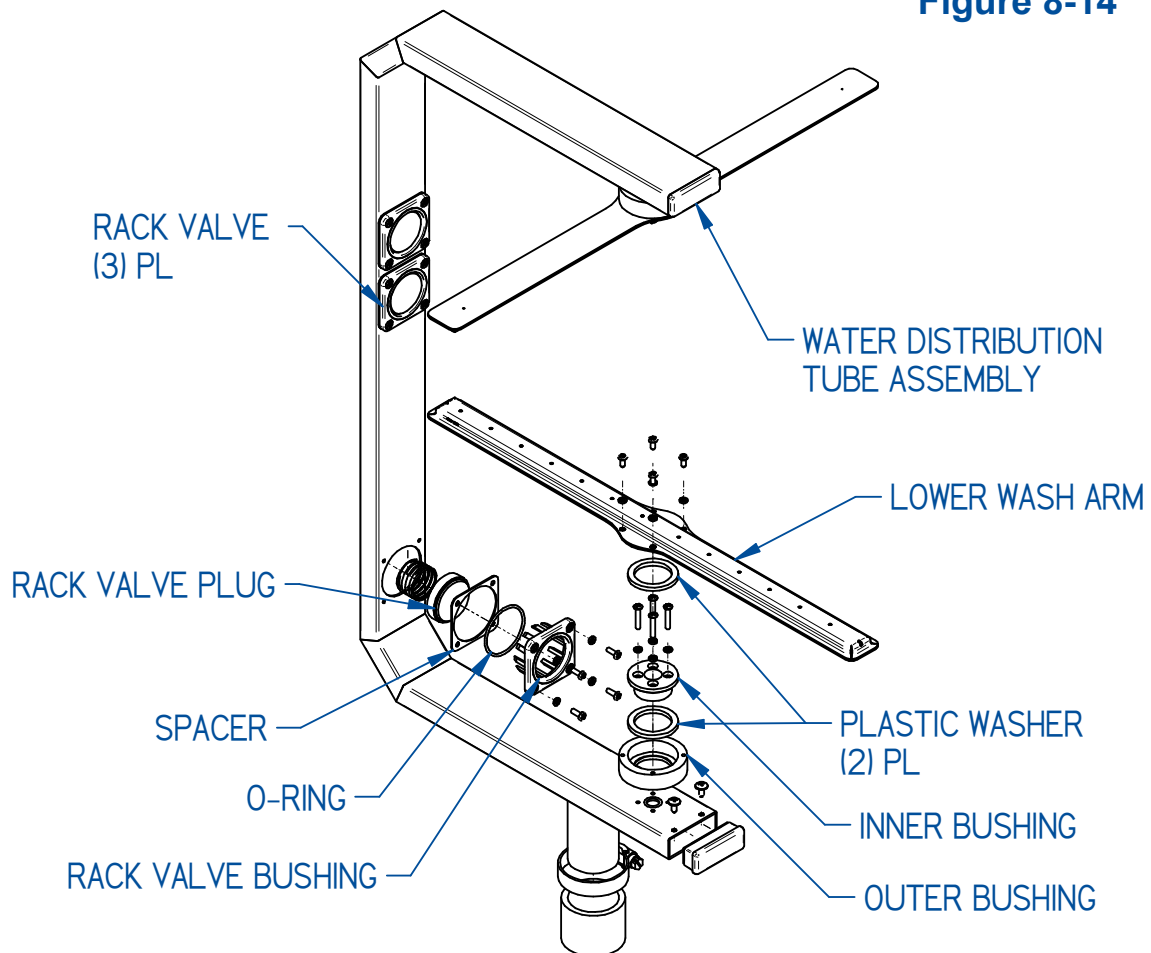

- Remove the four screws securing the wash arm to the outer bushing.
- Remove the four screws securing the inner bushing to the distribution tube.
- Check and clean the wash arm, inner and outer bushing as required.
- Remove and replace the two plastic washers as needed.
- Reassemble the wash arm.

Replacing the Rack Valve Bushing

All glassware washer models are equipped with three rack valves located in the distribution tube assembly at the back of the washer. When an upper rack or lower spindle rack is inserted into the washer, the rack valves allow water to flow to the middle wash arms and/or the spindle rack. You can check the operation of the valves by pressing in on the center of the plug to make sure the plug seats properly in the center of the valve bushing. If the valve bushing is damaged and needs replaced refer to the following instructions. Refer to figure 8-14.

- Remove the four screws securing the valve bushing to the distribution tube.
- This will allow you to remove the rack valve bushing, spacer, O-ring, rack valve plug and rack valve spring.
- Place the O-ring over the new bushing and the spacer plate over the O-ring.
- Insert the plug into the bushing and the spring into the plug.
- Place this assembly into the hole in the distribution tube.
- You will have to compress the spring while holding the bushings mounting hole in position with one hand while starting the mounting screws with the other hand.
- Once all four screws are started you can tighten the screws evenly in an alternating pattern.
- Once assembled, press in, and release the center of the plug to confirm it will freely move and return to seat in the center of the rack valve bushing.

Adjusting Rack Bumpers

The lower spindle rack and all upper racks plug into and seal against the valves located on the distribution tube in the back of the washer. If the racks are not getting a good seal at the valve when the door is closed, washability could suffer. Adjust the two bumpers located on each side of the rack moving them out to achieve a better seal between the rack the water distribution tube valves as the door closes.

9: Accessories & Consumables

This section details the available field-installable accessories and approved modifications for your glassware washer.

Rack Inserts for Labware

All inserts can be used in all Labconco Glassware Washer models. Catalog numbers are listed in Table 9-1 below.

Table 9-1

Insert Description	Catalog Number
Tray Insert	4573000
Utensil Basket	4573100
Petri Dish Insert	4589701
Mesh Basket	4573400
Bulk Tube Insert	4573500
Culture Tube Insert, 10 - 12 mm Tubes *	4573600
Culture Tube Insert, 15 – 18 mm Tubes	4573700
Culture Tube Insert, 20 – 24 mm Tubes	4573800
Retainer Top	4573900
10-Pin Insert	4401501
32-Pin Insert	4401801
48-Pin Insert	4574200
Cover, Insert Rack(10-Pin &32-Pin Inserts)	4401901
Utensil Holder	4575200

* Includes Retainer Top 4573900

Catalog numbers of inserts that require a spindle rack are listed in Table 9-2.



A lower spindle rack is included standard on FlaskScrubber Vantage models.

Table 9-2

Insert Description	Catalog Number
Graduate Cylinder Support	4574600
Test Tube Insert, 10 – 13 mm tubes *	4574700
Test Tube Insert, 14 – 20 mm tubes *	4574800
Test Tube Insert, 20 – 25 mm tubes *	4574900
Test Tube Spindle Conversion Kit	4575300
Vial Insert, 12 mm vials	4574400
Vial Insert, 15 mm vials	4574500
Pipette Insert (6)	4575500
Pipette Insert (24)	4575400

* Requires 4575300

Racks

Additional racks expand the capability of glassware washers. Catalog numbers are listed in Table 9-3.

Table 9-3

Rack Description	Catalog Number	Additional Information
Upper Spindle Rack	4668500	36 Large Spindles, includes Slides
Upper Spindle Rack	4668600	36 Large Spindles, excludes Slides
Upper Small Spindle Rack	4668501	60 Small Spindles, includes Slides
Upper Small Spindle Rack	4668601	60 Small Spindle, excludes Slides
Lower Spindle Rack *	4668900	36 Large Spindles
Lower Small Spindle Rack	4668901	60 Small Spindles
Upper Standard Rack **	4668700	Includes Slides
Upper Standard Rack	4668800	Excludes Slides
Lower Standard Rack **	4669000	
Upper Rack Retrofit Kit	4670600	For washers built prior to 11/20

* Indicates rack supplied standard with Vantage and FlaskScrubber models.

** Indicates rack supplied standard with SteamScrubber models.

Rack Accessories

Glassware holders and small spindles allow spindle racks to be modified to suit specific requirements. Catalog numbers are listed in Table 9-4 below.

Table 9-4

Insert Description	Catalog Number
Large Stainless Steel Glassware Holder	4424800P
Small Stainless Steel Glassware Holder	4424600P
Universal Plastic Glassware Holder	4585204
Small Spindles and Clips (10 pack)	4670800P
Spray Spindle	4575700
Wash Arm with 5 Small Spindles	4575800
Silicone Spindle Tip (40 pack)	4669540

Heater Cover Kit

A heater cover provides a protective barrier between the washer chamber and the heater coils to prevent objects that may become dislodged during washing from contacting the heater coils. Catalog numbers are listed in Table 9-5 below.

Table 9-5

Heater Cover Fits	Catalog Number
Vantage	4679301
SteamScrubber	4679300
FlaskScrubber	4679301

Liquid Detergent and Rinse Aid Dispensers

When added to SteamScrubber and FlaskScrubber models, these kits allow user-specified volumes of liquid detergent and/or rinse aid to be dispensed from bulk containers. Catalog numbers are listed in Table 9-6 below.

Table 9-6

Dispenser Description	Catalog Number
Detergent Dispenser	4587520
Rinse Aid Dispenser	4595120
Detergent and Rinse Aid Dispenser	4679700
Dispenser Enclosure *	4643000

*This kit provides an enclosure for the Liquid Detergent and/or Rinse Aid Dispenser Kits when added to a FlaskScrubber or SteamScrubber model.

Cool Drain Water Kit

The Cool Drain Water Kit mixes cool water with hot washer drain water to lower the temperature of the drain water to meet certain drain temperature regulations. Catalog numbers are listed in Table 9-7 below.

Table 9-7

Cool Drain Water Kit Fits	Catalog Number
230 V Models	4678401
115 V Models	4678400

Base Stand

Base Stands are used to elevate glassware washers to make loading and unloading more ergonomic for the user. Supplies may also be stored in the base stand's integral cabinet. Catalog numbers are listed in Table 9-8 below.

Table 9-8

Base Stand Fits	Catalog Number
Vantage Models	4653300
FlaskScrubber & SteamScrubber Models	4653500

Printer Kit

This kit provides the capability to connect a printer to the glassware washer. The catalog number is listed in Table 9-9 below.

Table 9-9

Printer Kit Fits	Catalog Number
Vantage Models	4681301
FlaskScrubber and SteamScrubber	4681300
Thermal Printer Paper	4683700

RO Storage Tank

RO Storage Tanks provide additional storage of pressurized reverse osmosis water for use with all glassware washers to accommodate rinsing glassware with pure water. Catalog numbers are listed in Table 9-10 below.

Table 9-10

RO Storage Tank Size	Catalog Number
20 Gallon	9201000
14 Gallon	9201001

ScrubberMate Cart

This cart provides convenient storage and transport for racks and inserts as well as miscellaneous glassware. The catalog number is listed in Table 9-11 below.

Table 9-11

Description	Catalog Number
ScrubberMate Cart	8027000

Freestanding Conversion Kit

The Freestanding Conversion Kit includes all the side panels and top to convert an undercounter washer to a freestanding model. The catalog number is listed in Table 9-12 below.

Table 9-12

Base Stand Fits	Catalog Number
Freestanding Conversion Kit	4601600

Consumables

Consumables recommended for use in glassware Washers are listed in Table 9-13 below.

Table 9-13

Description	Catalog Number
LabSolutions Powder Detergent 10 lb. (4.5 kg)	4422000
LabSolutions Powder Detergent 27.5 lb. (12.5 kg)	4422100
LabSolutions Liquid Detergent 1 gal (3.8 L)	4522000
LabSolutions Neutralizing Acid Rinse 34 oz. (1 L)	4522200
HEPA Filter	4597300
Thermal Printer Paper	4683700

Appendix A: Parts List

Table A-1 lists catalog numbers for service and replacement accessory components.

Figure A-1

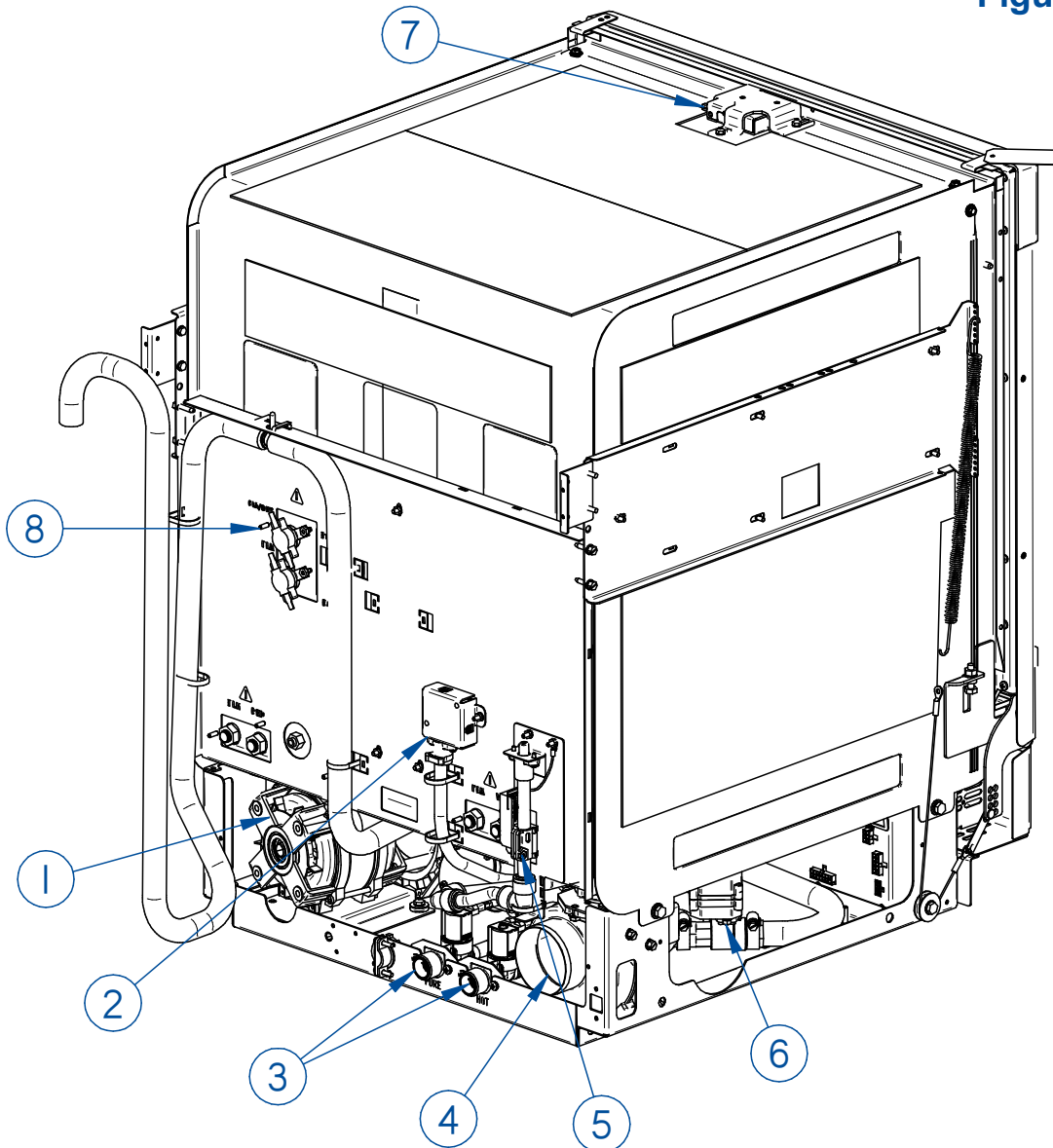

Parts List

Table A-1

Item #	Parts Description	Catalog
1	Wash Pump 115V	4584200
1	Wash Pump 230V	4584201
2	Pressure Sensor Board	4674200
3	Inlet Valve 12V	4670500
4	Blower 12V	7909600
5	Overfill Sensor(Mfg after 7/25)^	4687330
5	Overfill Sensor(Mfg after 8/23 prior to 7/25)^	4687320
5	Overfill Switch(Mfg prior to 8/23)^	4687310
6	Drain Valve 115V (Prior to 07/22)	4586900P
6	Drain Valve 230V (Prior to 07/22)	4586901P
6	Drain Valve 115/230V (After 07/22)	4685600
7	Door Latch 12V	4659100
8	Thermostat	4529700
9	Door Seal	4488500
10	Left Slide Assembly	4658901
11	Right Slide Assembly	4658900
12	Heater Three 230V (outer)**	4658700
13	Heater Two 230V (center)**	4658600
14	Heater One 230V (inner)	4584101
14	Heater One 115V	4584100
15	LED Light Assembly *	4671400
16	Detergent Dispenser Kit	4671701
17	Sump Screen	4658500
18	Tank Spray Arm	4667400
NS***	Rack Spray Arm	4667300
19	Plastic Washer (Spray Arm) 2 per arm	4668000
20	Drain Pump 115V	4663400P
20	Drain Pump 230V	4663401P
21	Fill Trap	4546601
22	Fill trap Nut	4546700
23	Rack Valve Bushing	4582501
24	Rack Valve Plug	4582601
NS***	Pure Pump 12V	4527900
25	IO Board	4687600
26	Heater 2&3 Relay	1289100
27	Heater One Triac	4673900
28	Drain Valve Relay (Prior to 07/22)	4683900
28	Drain Valve Relay (After 07/22)	1289200
29	Pump Relay x 2/Unit	1289200
30	Power Supply 12V	4678500
NS***	Control & Display Board Assembly	4688400

* On Window models only. **3-Phase models only. ***Not Shown ^Upgrade Kit, Mfg. Dates Approx.

Figure A-2

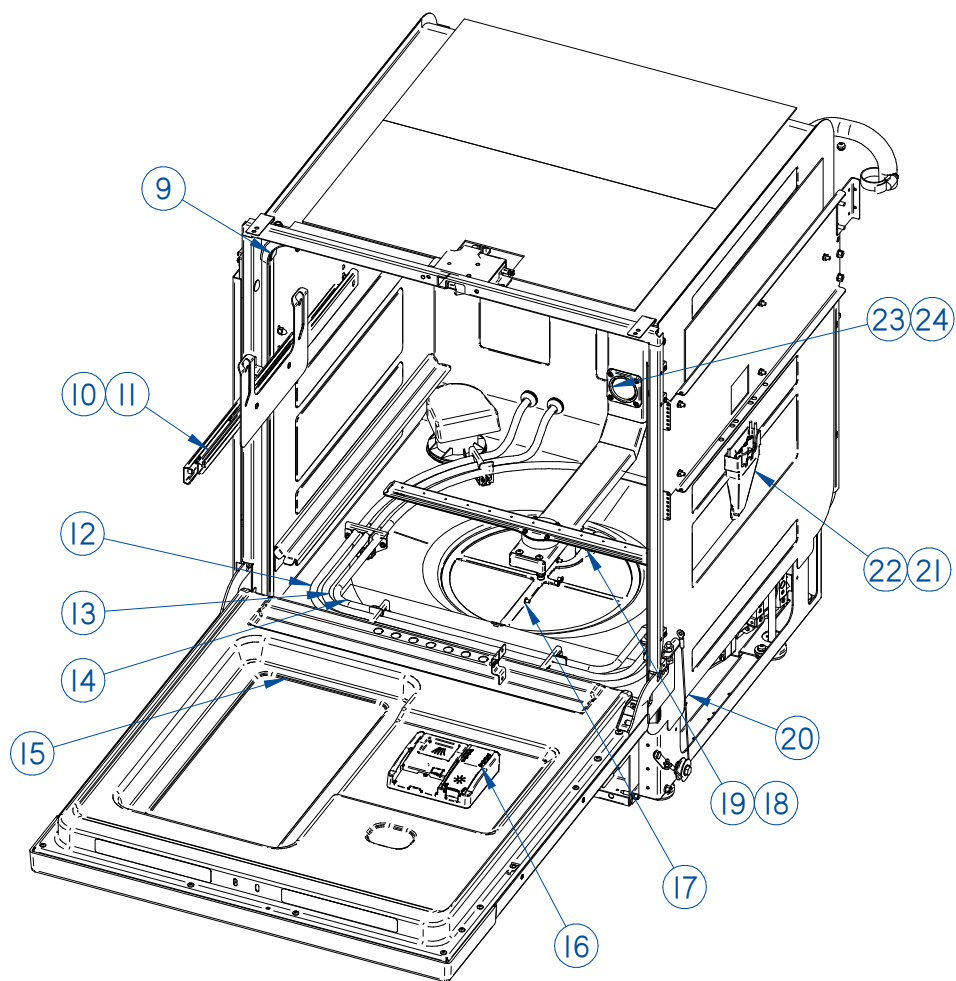
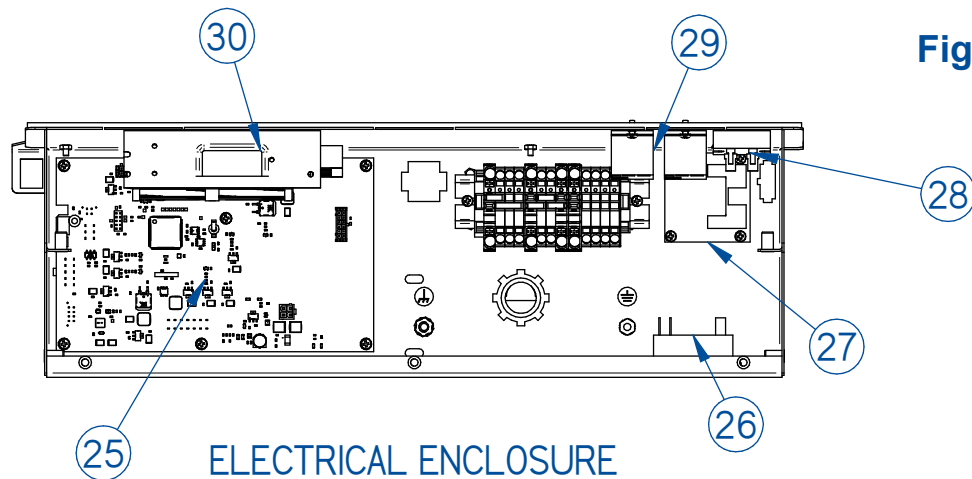

Figure A-3



Appendix B: Dimensions

Undercounter Exterior Dimensions

Figure B-1

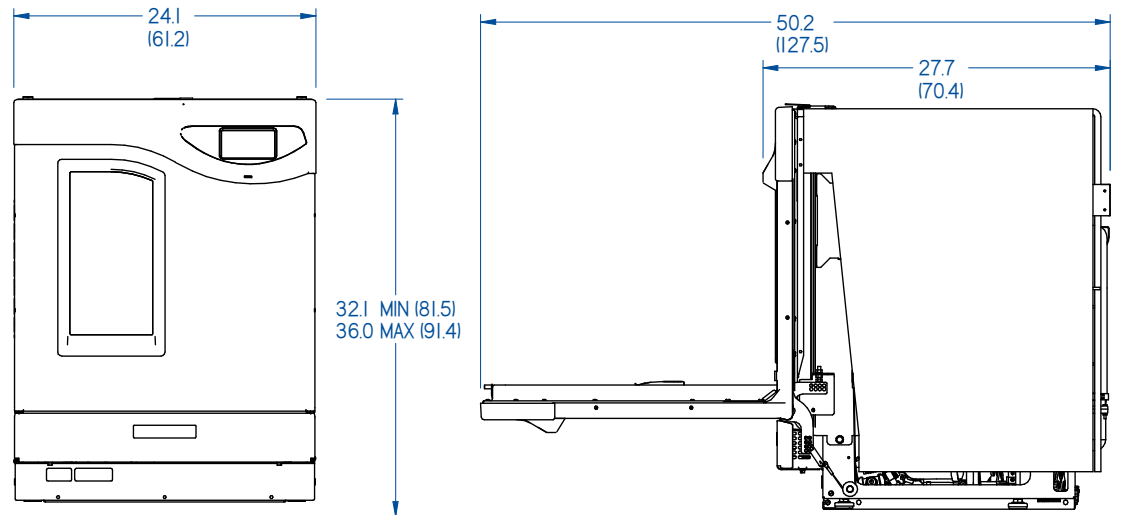

Freestanding Exterior Dimensions

Figure B-2

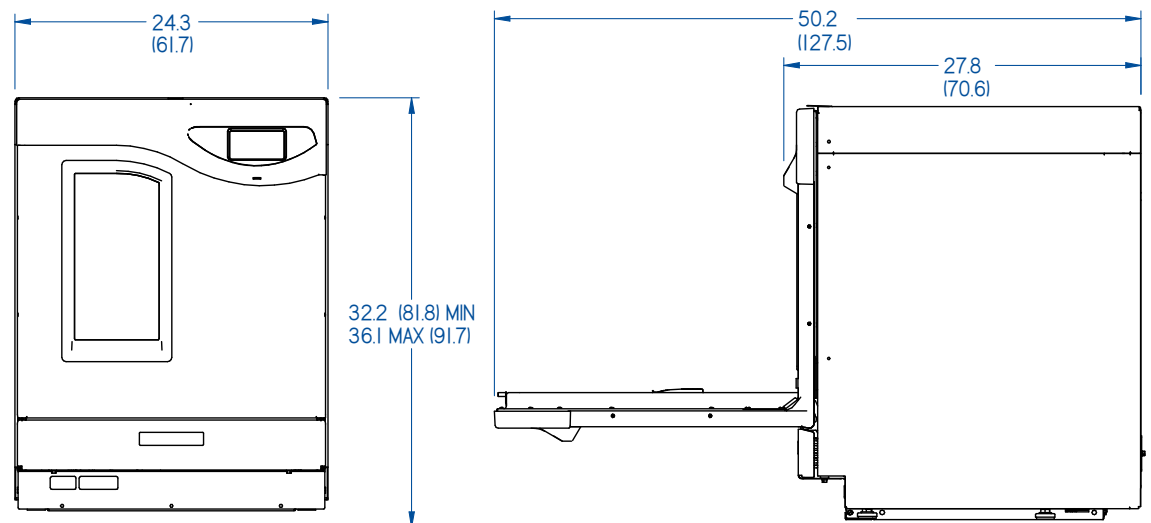

SteamScrubber Interior Dimensions

Figure B-3

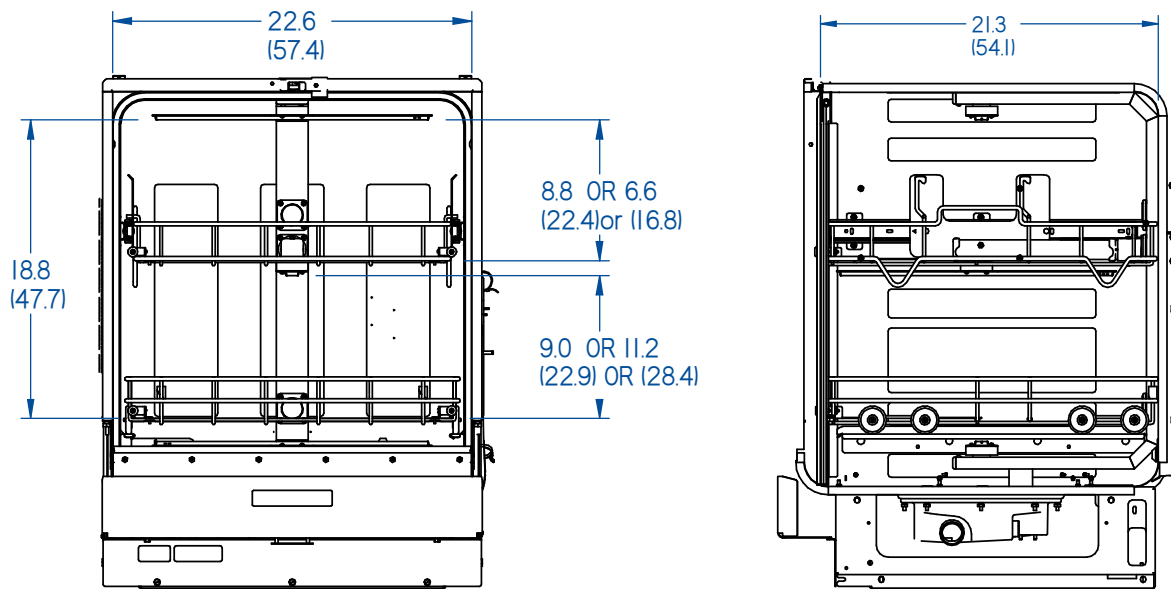

FlaskScrubber Interior Dimensions

Figure B-4

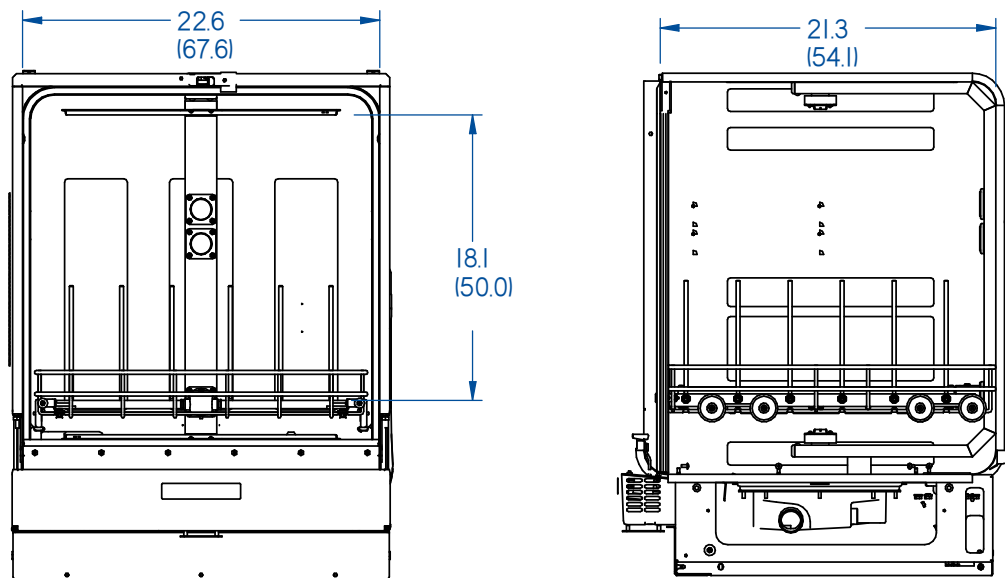

FlaskScrubber Vantage Exterior Dimensions

Figure B-5

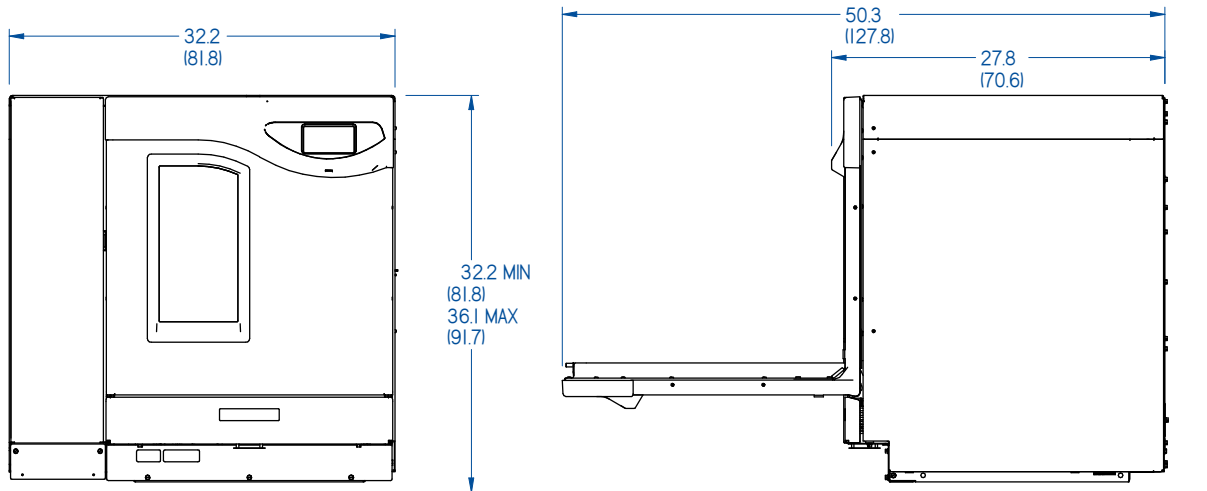

FlaskScrubber Vantage Interior Dimensions

Figure B-6

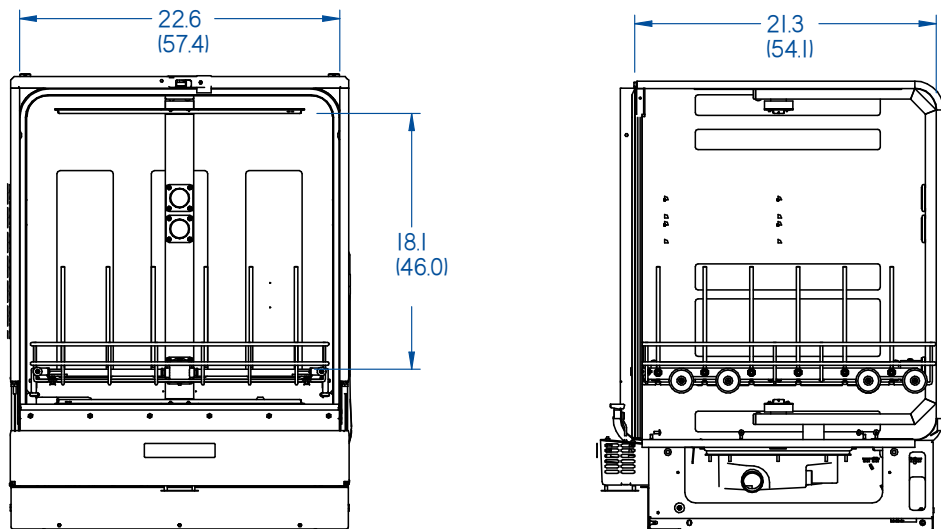

Appendix C: Specifications

This Appendix contains specifications for the Glassware Washer, including estimated program times and water consumption.

Programs

Table C-1

FACTORY PROGRAMS: FLASKSCRUBBER VANTAGE												
Segment	Rinse Only	Plastic	Glass	Glass Plus	Life Scientific	Analytical	Intense*	Extreme*	Dry Only	Eco Wash	Clean Washer	CleanPoint **
Pre-Wash Time												
Wash Time		5	5	5	5	5	5	10		5	1	5
Temperature (°C)		38	38	38	38	38	38	38		38	80	38
Tap Fill		X	X	X	X	X	X	X		X	X	X
Pure Fill												
Det Disp Cup (Auto mL)							A20	A20				A20
Wash 1												
Steam Time				10	10			10				
Wash Time		10	10	15	20	20	30	40		10		5
Temperature (°C)		50	60	70	80	70	93	93		60		93
Tap Fill		X	X	X	X	X	X	X		X		X
Pure Fill												
Det Disp Cup (Auto mL)		Cup	Cup	Cup	Cup	Cup	A20	A20		Cup		
Wash 2*												
Steam Time								10				
Temperature (°C)							93	93				
Wash Time							30	40				
Tap Fill							X	X				
Pure Fill												
Auto Det Disp (mL)							A20	A20				
Rinse 1/8 Tap												
Rinse Time	5	5	5	5	5	5	5	5		5	1	4
Temperature (°C)	38	38	38	38	38	38	38	38		38	80	38
Tap Fill	X	X	X	X	X	X	X	X		X	X	X
Pure Fill												
Rinse Aid Cup ml (Auto mL)		Cup 4	Cup 4	Cup 4	Cup 4	Cup 4	A 4	A 4		Cup 4		A 4
Rinse 2/8												
Rinse Time		5	5	5	5	5	5	5				2
Temperature (°C)		50	60	38	38	38	38	38				38
Tap Fill		X	X	X	X	X	X	X		X		
Pure Fill												X

Segment	Rinse Only	Plastic	Glass	Glass Plus	Life Scientific	Analytical	Intense*	Extreme*	Dry Only	Eco Wash	Clean Washer	CleanPoint**
<i>Rinse Aid Cup ml (Auto mL)</i>		Cup 4	Cup 4	Cup 4	Cup 4	Cup 4	A 4	A 4		Cup 4		
Rinse 3/8												
Rinse Time				5	5	5	5	5				2
<i>Temperature (°C)</i>				70	38	38	38	38				38
Tap Fill				X	X	X	X	X				
Pure Fill												X
<i>Rinse Aid Cup ml (Auto mL)</i>												
Rinse 4/8												
Rinse Time					5	5	10	5				2
<i>Temperature (°C)</i>					70	70	38	38				38
Tap Fill					X	X	X	X				
Pure Fill												X
<i>Rinse Aid Cup ml (Auto mL)</i>												
Rinse 5/8												
Rinse Time							5	5				2
<i>Temperature (°C)</i>							93	93				38
Tap Fill							X	X				
Pure Fill												X
<i>Rinse Aid Cup ml (Auto mL)</i>												
Rinse 6/8												
Rinse Time												2
<i>Temperature (°C)</i>												38
Tap Fill												
Pure Fill												X
<i>Rinse Aid Cup ml (Auto mL)</i>												
Rinse 7/8												
Rinse Time												2
<i>Temperature (°C)</i>												38
Tap Fill												
Pure Fill												X
<i>Rinse Aid Cup ml (Auto mL)</i>												
Rinse 8/8												
Rinse Time												2
<i>Temperature (°C)</i>												38
Tap Fill												
Pure Fill												X
<i>Rinse Aid Cup ml (Auto mL)</i>												
Dry												
Dry Time		15	30	60	40	40	50	60	60	15	30	30
<i>Temperature (°C)</i>		60	70	80	70	80	70	80	80	80	80	80
Open Door										5		
Total Estimated Time**	10	57	81	141	131	119	230	265	60	53	58	152

*Programs with Wash 2 are only available with Auto Dispense option. ** Available on Vantage only.

**Estimated times based on 3-phase unit. 49C water supply. Actual heat rates, fill and drain times will vary.

Power Data

Table C-2

Catalog Number	Volts	Phase	Cycles	Amps*
401x01000	115	1	60	16
401x01010	208/230	1	50/60	11
401x01013	208/230/400	3	50/60	21/19
402x01000	115	1	60	16
402x01010	208/230	1	50/60	11
402x01013	208/230/400	3	50/60	21/19
411x01000	115	1	60	16
411x01010	208/230	1	50/60	11
411x01013	208/230/400	3	50/60	21/19
412x01000	115	1	60	16
412x01010	208/230	1	50/60	11
412x01013	208/230/400	3	50/60	21/19
422101010	208/230	1	50/60	11
422101013	208/230/400	3	50/60	21/19

* Amperage values may vary depending upon supply voltage.

Fill and Heat Specifications

- Minimum fill water temperature: 120°F (49°C) recommended
- Maximum fill water temperature: 199°F (93°C)
- Water consumption per fill: 3.4 gallons (13 L)
- Minimum tap feed water pressure: 20 psi (138 kPa)
- Maximum tap feed water pressure: 120 psi (827 kPa)
- Minimum tap feed water flow rate: 1.25 gallons (4.7 liters) per minute
- Minimum feed purified water pressure: 0 psi (0 kPa)
- Maximum feed purified water pressure: 120 psi (827 kPa)
- Minimum pure water flow rate: .9 gallons (3.4 liters) per minute
- Heat rejected from washer* 1200W: < 68 BTU/minute
- Heat rejected from washer* 2000W: < 114 BTU/minute
- Water heating rate**115V 1200W: 1.2°F/minute (0.7°C/minute)
- Water heating rate^ 230V 2000W: 3.1°F/minute (1.7°C/minute)

Wash Pump and Heater(s) On

**1200W Models - Heat Rate from 50°C to 82°C

^2000W and 6000W Models - Heat Rate from 50°C to 93°C

Environmental Conditions

- Indoor use only
- Ambient temperature range: 41° to 95°F (5° to 35°C)
- Maximum altitude: 10,000 feet (3,048 meters).
- Maximum relative humidity: 70% for temperatures up to 78°F (31°C), decreasing linearly to 40% relative humidity at 95°F (35°C)
- Main supply voltage fluctuations not to exceed $\pm 10\%$ of the nominal voltage
- Transient overvoltages according to Installation Categories II (Overvoltage Categories per IEC 1010). Temporary voltage spikes on the AC input line that may be as high as 1500V for 115V models and 2500V for 230V models are allowed
- Used in an environment of Pollution degrees 2 (i.e., where normally only non-conductive atmospheres are present). Occasionally, however, a temporary conductivity caused by condensation must be expected in accordance with IEC 664

