



Please read user's manual before
operating equipment

Original Instructions

LABCONCO CORPORATION

8811 Prospect Avenue
Kansas City, MO 64132
(800) 821-5525 | +1 (816) 333-8811
labconco.com

User's Manual

Spectrum™ Blowers



Register this product

Spectrum™ Blower Coated Steel Models

2022—Present

177050100 177250100 177250200

Spectrum™ Blower Fiberglass Models

2022—Present

177051100 177251100 177251200

Spectrum™ Blower PVC Models

2022—Present

177052100 177252100 177252200

Copyright © 2022 Labconco Corporation. The information contained in this manual and the accompanying products are copyrighted and all rights reserved by Labconco Corporation. Labconco Corporation reserves the right to make periodic design changes without obligation to notify any person or entity of such change.

Warranty

Labconco Corporation provides a warranty to the original buyer for the repair or replacement of parts and reasonable labor as a result of normal and proper use of the equipment with compatible chemicals. Broken glassware and maintenance items, such as filters, gaskets, light bulbs, finishes and lubrication are not warranted. Excluded from warranty are products with improper installation, erratic electrical or utility supply, unauthorized repair and products used with incompatible chemicals.

Spectrum™ Blowers carry a one-year warranty from date of installation or two years from date of shipment from Labconco, whichever is sooner. Warranty is non-transferable and only applies to the owner (organization) of record.

Buyer is exclusively responsible for the set-up, installation, verification, decontamination or calibration of equipment. This limited warranty covers parts and labor, but not transportation and insurance charges. If the failure is determined to be covered under this warranty, the dealer or Labconco Corporation will authorize repair or replacement of all defective parts to restore the unit to operation. Repairs may be completed by 3rd party service agents approved by Labconco Corporation. Labconco Corporation reserves the rights to limit this warranty based on a service agent's travel, working hours, the site's entry restrictions and unobstructed access to serviceable components of the product.

Under no circumstances shall Labconco Corporation be liable for indirect, consequential, or special damages of any kind. This warranty is exclusive and in lieu of all other warranties whether oral, or implied.

Returned or Damaged Goods

Do not return goods without the prior authorization from Labconco. Unauthorized returns will not be accepted. If your shipment was damaged in transit, you must file a claim directly with the freight carrier. Labconco Corporation and its dealers are not responsible for shipping damages.

The United States Interstate Commerce Commission rules require that claims be filed with the delivery carrier within **fifteen (15) days** of delivery.

Limitation of Liability

The disposal and/or emission of substances used in connection with this equipment may be governed by various federal, state, or local regulations. All users of this equipment are required to become familiar with any regulations that apply in the user's area concerning the dumping of waste materials in or upon water, land, or air and to comply with such regulations. Labconco Corporation is held harmless with respect to user's compliance with such regulations.

For additional questions or support:

Labconco Customer Care +1 (816) 333-8811

Labconco Technical Support (800) 821-5525

Hours 7:30 a.m.-5:30 p.m. CST

**Part #7170800 Rev. C
ECO 15411**

Table of Contents

1: INTRODUCTION	8
Location Requirements	8
About This Manual	8
Contents Included	9
2: BEFORE YOU INSTALL	10
Mounting Stand Requirements	10
Electrical Requirements	11
Exhaust Requirements	11
3: SAFETY PRECAUTIONS	12
Typographical Conventions	12
General Safety Precautions	14
Safety Precautions for this Product	16
4: INSTALLATION	17
Unpacking	17
Installing the Blower	18
Adjust Outlet Orientation	19
Connect to Blower Inlet	20
Connect to Blower Outlet	20
Connect Electrical Service	23
Connect PVC Drain (For PVC Blowers Only)	26
5: PERFORMANCE FEATURES	27
Built-in Vibration Isolation	27
ECM Motor & VFD Motor	27

Multiple Input Control Options	27
Data Output	28
Temperature Monitoring	28
Universal Operating Voltage	28
On Board USB Port	29
Switched Relay Output	29
6: SPECTRUM BLOWER FAN SPEED OPERATING SYSTEM	30
Control panel	30
Remote Blower ON/OFF Switch	31
On-Board Potentiometer	35
0-10Vdc Input	36
4-20mA Input	38
7: USING YOUR SPECTRUM BLOWER	40
Control Display	40
Data Outputs	41
Menu Navigation	41
Settings	42
Performance Data – Download Log File	45
Software Update	45
Alarm Contact (Blower ON Contact)	46
8: MAINTAINING YOUR SPECTRUM BLOWER	47
Maintenance Safety Precautions	47
Recommended Maintenance Schedule	48
Service Operations	48
9: ACCESSORIES	51

Mounting Stand	51
Vibration Isolator Kit, (#7174900)	51
Thermoplastic Duct	52
Duct Couplings, Female	52
Duct Couplings, Male	52
Elbows	53
Thermoplastic Duct Reducers	53
Zero Pressure Weathercaps	54
Spiral Tube	54
Manual Duct Dampers	54
Flexible Duct Connections	55
Blower Transition Adaptors	55
T and Y Connections	55
Backdraft Dampers	56
Accessory for perchloric Acid Applications	56
10: TROUBLESHOOTING	57
Contamination Outside Fume Hood	57
Control Panel Display Not Functioning, Blower OK	57
Blower Not Working, Error Code 'B'	58
Blower Has Excessive Vibration	59
Fume Hood Has Improper Face Velocity	60
Overcurrent, Error Code 'C'	60
Overheating, Error Code 'T'	61
Too Cold for Motor to start, Error Code 'T'	61
APPENDIX A: PARTS LIST	62
APPENDIX B: DIMENSIONS	67

Coated Steel Blowers	67
Fiberglass Blowers	68
PVC Blowers	69
APPENDIX C: SPECIFICATIONS	70
Wiring Diagrams	70
Motor Specifications	72
Environmental Conditions	72
APPENDIX D: BLOWER CURVES	73
10" Coated Steel, 1 HP ECM	74
10" Fiberglass, 1 HP ECM	75
10" PVC, 1 HP ECM	76
12" Coated Steel, 1 HP ECM	77
12" Fiberglass, 1 HP ECM	78
12" PVC, 1 HP ECM	79
12" Fiberglass or PVC, 2 HP VFD Motor	80
12" Coated Steel, 2 HP VFD Motor	81
APPENDIX E: CONNECTING THE SPECTRUM BLOWER TO A GUARDIAN DIGITAL AFM (AIRFLOW MONITOR)	82

1: Introduction

Congratulations on the purchase of a Spectrum™ Blower. The Spectrum Blower is designed to meet the demanding requirements of most laboratory ventilation situations associated with an exposure control device (i.e. fume hood, biosafety cabinet, chemical storage, general exhaust, etc.). It is the result of years of experience in manufacturing laboratory equipment, and users like you suggested many of its features to us.

This Spectrum Blower offers many unique features. To take full advantage of them, please acquaint yourself with this manual and keep it handy for future reference.

Location Requirements

Make sure that it is away from all other types of air handling equipment (intake fans, air conditioning units, etc.). Location of the blower inlet with respect to the device you are exhausting must be considered. Proper planning and layout are essential in selecting a blower location. Allow for sufficient space for service.

About This Manual

This manual is written for the installer and user of this product.



This manual contains important operation and safety information. When you see a symbol, such as the INFO symbol to the left, pay close attention to the information provided. Before installing or operating this product, you must read [Section 3: Safety Precautions](#).

Contents Included

The following items are packaged with the product.

- User's manual

The location of these items and additional details are found in [Section 4: Installation](#).

2: Before You Install

Before you install the product, the site should be planned for installation. Examine the location where you intend to install it. You must be certain that the area is level and of solid construction. In addition, a dedicated source of electrical power must be located near the installation site.

See [Appendix B: Dimensions](#) for overall product dimensions.

Mounting Stand Requirements

A roof curb support must be acquired for proper mounting of the blower. The mounting stand must be taller than expected rain and snowfall in the area. In addition to the curb, vibration isolators or vibration mounting pads improve the support for blowers. Vibration isolators or vibration mounting pads are available from many sources such as a local industrial supply company. Labconco recommends supporting the blower with 5/16" diameter mounting hardware. See [Section 9: Accessories](#) for curb support and vibration isolator options.

Electrical Requirements

The product models have the following electrical requirements.

Catalog Number	Full Load Amps	Electrical Circuit Requirements*	
177x5x100	10 / 6	100-125V / 208-250V, 50/60 Hz	1 Phase
17725x200	8.5	208-250V, 50/60 Hz	1 Phase / 3 Phase

*Electrical Requirements, 'V' = VAC (Voltage with alternating current), 'A' = Amperes

Exhaust Requirements

Ducting above the roofline is required to generate proper air dispersion of materials or containments exhausted through the blower.

Each blower serving laboratory equipment shall be field labeled to indicate the specific equipment served; and adequately sized by a qualified professional to provide exhaust flow sufficient to maintain negative static pressure in all parts of the mechanical system located indoors, required transport velocity, exit velocity, and volumetric rate.

Per ANSI/ASSP Z9.5, if flammable vapor or gas of combustible dust is present in the airstream above 20% of the LEL/LFL, blower construction shall be as recommended by AMCA 99-0401, *classifications for spark resistant construction*.

Exhaust stack design and discharge velocity shall be such that requirements in ANSI/ASSP Z9.5 and NFPA 45 are met, in any event the discharge height shall be a minimum of 10 feet above adjacent roofline and air intakes in the vertical up direction.

3: Safety Precautions

Before unpacking, installing, operating, maintaining, or servicing this equipment, read the following safety warnings and precautions.

Avant le déballage, l'installation, le fonctionnement, l'entretien ou la maintenance de cet équipement, lire les avertissements de sécurité et les précautions d'emploi.



CAUTION – See Manual. When this symbol is on the equipment, it indicates a caution that is detailed in this manual.

MISE EN GARDE – Voir le manuel. Lorsque ce symbole est apposé sur l'équipement, il renvoie à une mise en garde détaillée dans ce manuel.

Typographical Conventions



DANGER – An imminently hazardous situation which, if not avoided, will result in death or serious injury.

DANGER – Situation dangereuse imminente qui, si elle n'est pas évitée, peut entraîner la mort ou des blessures graves.



CAUTION – Indicates a potentially hazardous situation which, if not avoided, may result in minor or moderate injury or damage to property.

MISE EN GARDE – Signale une situation potentiellement dangereuse qui, si elle n'est pas évitée, peut provoquer des blessures mineures à modérées ou des dommages matériels.



NOTE – Advice or suggestions to help the process.

REMARQUE – Conseils ou suggestions pour le déroulement du processus.



BURN RISK (HIGH TEMPERATURE) – Air or components that will be very hot. Take care not to touch these defined areas. Failure to avoid these areas may result in moderate to severe injury.

RISQUE DE BRÛLURE (TEMPÉRATURE ÉLEVÉE) – Air ambiant ou composant devenant très chaud. Veiller à ne pas toucher ces zones délimitées. L'absence de précaution pour éviter ces zones peut entraîner des blessures modérées, voire graves.



EXTREME COLD (LOW TEMPERATURE) – Air or components that will be very cold. Take care not to touch these defined areas. Failure to avoid these areas may result in moderate to severe injury.

FROID INTENSE (TEMPÉRATURE BASSE) – Air ambiant ou composant devenant très froid. Veiller à ne pas toucher ces zones délimitées. L'absence de précaution pour éviter ces zones peut entraîner des blessures modérées voire graves.



PINCH POINT – Areas or components that can pinch or cut. Take care not to touch these defined areas.

POINT DE PINCEMENT – Zones ou composants présentant un risque de pincement ou de coupure. Veiller à ne pas toucher ces zones délimitées.



MOVING PARTS – Areas or components that contain moving parts. Take care not to touch these defined areas.

PIÈCES MOBILES – Zones ou composants contenant des pièces mobiles. Veiller à ne pas toucher ces zones délimitées.



RISK OF ELECTRICAL SHOCK – The specified procedure or area poses a risk of electrical shock. ALWAYS disconnect main power cord or electrical supply before proceeding.

RISQUE DE CHOC ÉLECTRIQUE – La procédure ou la zone spécifiée présente un risque de choc électrique. TOUJOURS débrancher le cordon d'alimentation secteur ou l'alimentation électrique avant toute intervention.



FLAMMABLE / NO SOLVENTS – Do not place flammable liquids or solvents in this product.

INFLAMMABLE / PAS DE SOLVANTS – Ne placez aucun liquid inflammable dans cette produit.



LIFTING HAZARD – Do not lift or move this equipment without assistance.

DANGER DE LEVAGE – Ne pas soulever ou déplacer cet équipement sans assistance.



MAGNETIC FIELD IN USE – Magnets or magnetic field present.

CHAMP MAGNETIQUE UTILISE – Présence d'aimants ou de champ magnétique.



DO NOT TOUCH – Components or areas indicated are sensitive and will suffer damage if touched. Take care not to touch these defined components or areas. Failure to avoid these areas will result in damage to the product.

NE PAS TOUCHER – Les composants ou les zones indiquées sont sensibles et subiront des dégâts s'ils sont touchés. Veiller à ne pas toucher ces composants ou zones délimité(e)s. L'absence de précaution pour éviter ces zones endommagera le produit.



TOOL REQUIRED – Tool required to access specified area.

OUTIL NÉCESSAIRE – Outil nécessaire pour accéder à la zone spécifiée.

General Safety Precautions

Follow all the safety precautions described in this section.



Before removing the weather panel, which requires a tool for removal, ALWAYS disconnect the main power cord or electrical supply. Failure to remove all electrical power before proceeding will result in moderate to serious injury, death, or damage to property.

Avant de retirer le panneau météo qui nécessite un outil pour le retrait, débranchez TOUJOURS le cordon d'alimentation principal ou l'alimentation électrique. Le non-respect de la consigne consistant à couper complètement l'alimentation électrique avant toute intervention peut entraîner des blessures graves, la mort ou des dommages matériels.



Never contact moving parts with your person. Failure to avoid moving parts will result in moderate to serious injury, death, or damage to property.

Ne jamais toucher les parties mobiles. Le non-respect de la consigne consistant à éviter les pièces mobiles peut entraîner des blessures graves, la mort ou des dommages matériels.



Never misuse this product. Never disable, override, or otherwise bypass safety guards, panels, switches, sensors or alarms. Doing so will result in moderate to serious injury, death, or damage to this product or property.

Ne jamais utiliser ce produit à mauvais escient. Ne jamais désactiver, annuler ou contourner les capots, panneaux, interrupteurs, capteurs ou alarmes de sécurité. Ceci entraînerait des blessures graves, la mort ou des dommages matériels à ce produit ou à d'autres biens.



If the unit is not operated as specified in this manual it may impair the protection provided by the unit.

Si l'unité n'est pas utilisée comme spécifié dans ce manuel il peut diminuer la protection fournie par l'unité.



Do not position the unit so that it is difficult to operate the main disconnect device. Main disconnect provided by others.

Ne placez pas l'appareil de sorte qu'il est difficile de faire fonctionner le dispositif principal de déconnexion. Déconnexion principale fournie par d'autres



Do not lift or move this equipment without assistance.

Ne pas soulever ou déplacer cet équipement sans assistance.

Safety Precautions for this Product



Do NOT contact blower wheel while still in motion.

NE PAS être en contact avec la roué du ventilateur tant qu'il est en marche.



Upon initial start-up, always wear protective eyewear. A qualified technician should certify the blower/hood system before it is initially used.

Après le démarrage initial, toujours porter des lunettes de protection. Un technicien qualifié doit certifier le système souffleur / capot avant est initialement utilisé.



The blower/hood system should be re-certified annually or whenever it is relocated.

Le système ventilateur / hotte doit être re-certifié chaque année ou chaque fois qu'il est déplacé.



Do not operate the blower at maximum speed unless airflow has first been certified and verified by a qualified certification company. Operating the blower at full speed without proper airflow verification may result in excessive static pressure within the duct system, which can cause the blower to overheat. In this condition, the blower will automatically reduce speed to protect the unit.

N'utilisez pas le ventilateur à sa vitesse maximale sans que le débit d'air n'ait été préalablement certifié et vérifié par un organisme de certification agréé. L'utilisation du ventilateur à pleine vitesse sans vérification adéquate du débit d'air peut entraîner une pression statique excessive dans le système de conduits, ce qui risque de provoquer une surchauffe du ventilateur. Dans ce cas, le ventilateur réduira automatiquement sa vitesse pour se protéger.

4: Installation

With the installation site properly prepared, you are ready to unpack and install the equipment. This section covers how to:

- Unpack and move the equipment
- Install the equipment
- Adjust outlet orientation
- Connect to blower inlet
- Connect a blower outlet (such as zero pressure weather cap)
- Connect electrical service
- Connect PVC drain (for PVC Blowers only)

Unpacking



The following tools are required to unpack the equipment:

- Box Knife



The following safety precautions must be followed by all personnel unpacking the equipment.

- Wear safety glasses
- Wear gloves
- No loose fitting clothes
- Wear close-toed shoes
- Follow safe-lifting practices

Step 1

Carefully remove the outer carton and inspect the product for damage that may have occurred in transit. If the product is damaged, take pictures of the product and the outer packaging, and notify the delivery carrier immediately. Retain the entire shipment, including outer packaging, intact for inspection by the carrier.



Note: United States Interstate Commerce Commission rules require that claims be filed with the delivery carrier within fifteen (15) days of delivery.

Do not return goods without the prior authorization of Labconco. Unauthorized returns will not be accepted.

If the product was damaged in transit, you must file a claim directly with the freight carrier. Labconco Corporation and its dealers are not responsible for shipping damages.

Do not discard the carton or packing material for the product until all of the components have been checked, installed and tested.

Installing the Blower



The following tools and materials are required to install the equipment:

- Vibration dampers
- Curb: mounting stand
- 5/16" diameter hardware
- Tools to secure 5/16" diameter hardware



The following safety precautions must be followed by all personnel installing the equipment.

- Wear safety glasses
- Wear gloves
- No loose fitting clothes
- Wear close-toed shoes
- Follow safe-lifting practices

Step 1

Blowers must be installed on a roof curb support. The supporting structure is custom for each installation. Curb must be in place prior to installing blower(s). See [Section 9: Accessories](#) for ordering information on a purchasable mounting stand.

Step 2

Labconco recommends supporting the blower with 5/16" diameter mounting hardware. See [Appendix B: Dimensions](#) for appropriate mounting hole locations.

Step 3

Installing vibration isolators or vibration mounting pads between the blower and curb is acceptable. Vibration dampers can be found at local industrial supply company.

Adjust Outlet Orientation

The blower housing can be rotated to facilitate the duct run configuration required. Most blowers are installed for upward discharge. If no outlet adjustment is needed, go to the next section.



The following tools are required to adjust the outlet orientation:

- Ratchet and 7/16" socket or 7/16" wrench
- 5/16" nut driver

Step 1

Using a 5/16" nut driver, remove the 6 screws holding the louvered weather cover in place shown in Figure 4-1. Lift off the weather cover. Save this cover and hardware.

Step 2

With the weather cover removed, locate and remove the 8 bolts (and lock washers) that secure the blower housing using a 7/16" wrench or ratchet shown in Figure 4-1. Once removed, the blower housing is free to rotate to the desired outlet orientation.

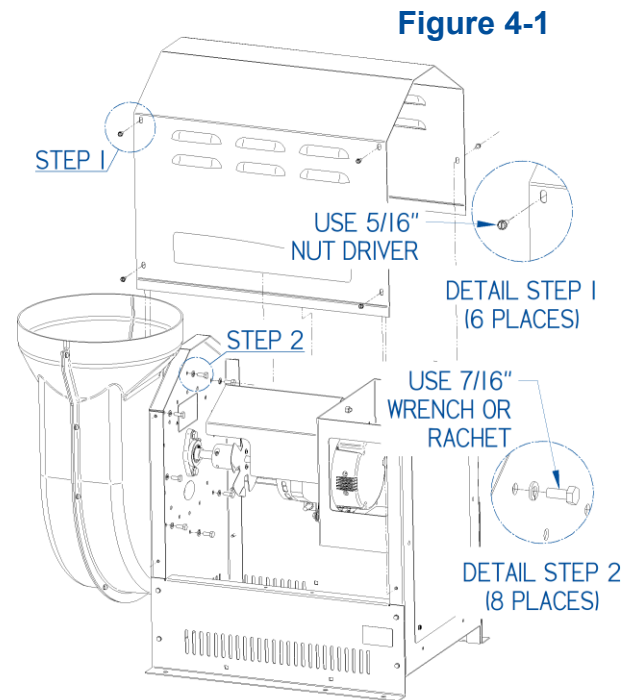

Step 3

Secure desired outlet position by reinstalling hardware removed in previous step. Reinstall weather cover and hardware saved from Step 1 using the 5/16" nut driver.

Connect to Blower Inlet

This section will detail how to install the inlet connection according to the blower material. See [Appendix A: Parts List](#) or see [Section 9: Accessories](#).

For Coated Steel Blowers

10" Coated Steel (CS) Blowers feature a 10-7/8" ID by 1-1/2" wide circular inlet ring. This inlet ring is suitable for use with 10-inch diameter PVC ductwork. *12" Coated Steel Blowers* feature a 12-1/4" OD by 1-1/2" wide inlet ring, which is suitable for use with 12-inch diameter PVC ductwork. The PVC ductwork itself will fit inside the inlet ring for the 10" blower and fit over the inlet ring on the 12" blower. The duct should be fastened by sheet metal screws through the inlet ring. A silicone sealant should also be used to seal between the ductwork and the blower inlet ring to prevent any air or moisture leakage.

For Fiberglass Blowers

10" Fiberglass Blowers feature a 10-3/8" OD inlet ring. This inlet ring is suitable for use with 10-inch diameter PVC ductwork. *12" Fiberglass Blowers* feature 12-3/8" OD inlet ring, which is suitable for use with 12-inch diameter PVC ductwork. The PVC ductwork will fit outside the inlet ring and should be fastened by sheet metal screws through the fiberglass inlet ring. A silicone sealant is to be used to seal between the ductwork and the blower inlet ring to prevent air or moisture leakage.

For PVC Blowers

10" PVC Blowers feature a 10-3/8" OD inlet ring. This inlet ring is suitable for use with 10-inch diameter PVC ductwork. *12" PVC Blowers* feature a 12-3/8" OD inlet ring, which is suitable for use with 12-inch diameter PVC ductwork. The PVC ductwork will fit outside the inlet ring through the PVC inlet ring. A silicone sealant should also be used to seal between the ductwork and the blower inlet ring to prevent air or moisture leakage.

Connect to Blower Outlet

Before proceeding with the blower outlet connection, read the two warnings and follow the suggested pictures listed next:



Should your exhaust stack, on the outlet side of the exhaust blower, extend over 7 feet, both guy wires and additional structural supports are required to carry the weight of this ductwork. The guy wires must be substantial enough to support the exhaust stack against high wind velocities. Figure 4-2 is a picture of a poor installation. See Figures 4-3, 4-4, and 4-5 for examples of a good installation.

Si votre cheminée d'échappement, sur le côté de sortie du ventilateur d'évacuation, s'étendent sur 7 pieds, les deux haubans et les supports structuraux supplémentaires sont nécessaires pour supporter le poids de cette canalisation. Les haubans doivent être suffisamment importants pour soutenir la cheminée d'échappement contre la vitesse des vents élevés. La figure 4-2 est une photo d'une mauvaise installation. Voir les figures 4-3, 4-4, et 4-5 pour des exemples d'une bonne installation.

Poor Installation



HINT: An exhaust damper either before or after the Spectrum Blower is very useful for fine tuning the airflow.

Figure 4-2



Blower damage can occur without structural supports and guy wires. (Please note the crooked exhaust duct when installed without structural supports and without guy wires.)

Good Installation – Single Blower

Figure 4-3



Two-piece C-clamp coupler supports exhaust duct diameter to secure weight load of duct carried by structural members.

Guy wires from 3 sides are supported off the roof to prevent wind velocities from deflecting the exhaust duct.

Structural support is connected to C-clamp

Note: Duct diameters, duct materials, and heights may vary. Labconco does not offer structural supports or guy wires.

Figure 4-4



Good Installation – Multiple Blower

Figure 4-5

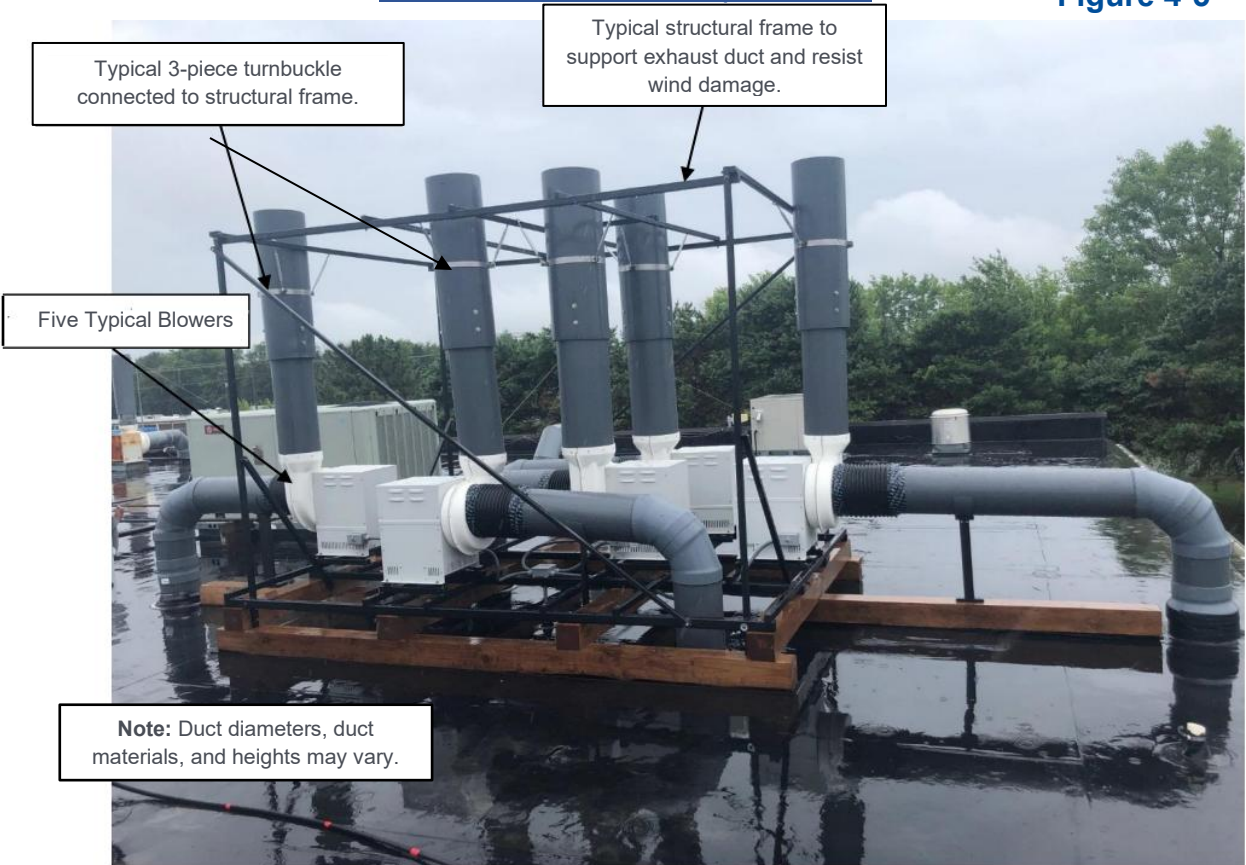

Labconco does not sell the structural supports or guy wires.

For Coated Steel Blowers

10" Coated Steel Blowers include a 10" by 5-1/2" rectangular outlet. A rectangular to round Transition Adaptor, Labconco part number 4722401, adapts the outlet connection to accept 10-inch diameter PVC ductwork. Labconco part number 4722400 adapts the outlet on these blowers to accept 8-inch diameter PVC ductwork.

12" Coated Steel Blowers include a 13-1/2" by 7" rectangular outlet. Transition Adaptor, Labconco part number 7003400, adapts the outlet of these blowers to accept 12-inch diameter PVC ductwork.

See [Section 9: Accessories](#) for additional information on outlet adaptors for Coated Steel Blowers.

For Fiberglass Blowers

10" Fiberglass Blowers feature a 10-3/4" ID outlet connection. 10-inch diameter ductwork will slip into this connection and should be held by sheet metal screws

through the housing. Silicone sealant should be used to seal any air leaks between the duct and blower outlet connection.

12" Fiberglass Blowers feature a 12-3/4" ID outlet connection. 12-inch diameter ductwork will slip into this connection and should be held by sheet metal screws through the housing. Silicone sealant should be used to seal any air leaks between the duct and blower outlet connection.

For PVC Blowers

10" PVC Blowers feature a 10-3/4" ID outlet connection. 10-inch diameter ductwork will slip into this connection and should be held by sheet metal screws through the housing. Silicone sealant should be used to seal any air leaks between the duct and blower outlet connection.

12" PVC Blowers feature a 12-3/4" ID outlet connection. 12-inch diameter ductwork will slip into this connection and should be held by sheet metal screws through the housing. Silicone sealant should be used to seal any air leaks between the duct and blower outlet connection.

Connect Electrical Service

The main electrical power supply connection for the Spectrum Blower is made directly at the junction box underneath the outer weather cover and below the motor. Refer to the wiring diagrams in [Appendix C: Specifications](#) and follow these steps.



An external disconnect is required and should not be mounted to the Spectrum Blower weather cover.

Step 1

Access the J-Box by removing the top weather cover (as shown in Figure 4-1) of the blower base. This weather cover is held in position by machine screws, and once they have been removed, you will have access to the J-Box of your blower.

Step 2

Run inlet power through the roof within the curb, to the J-box of the Spectrum Blower.



The gap between the end panel and the base allows electrical conduit to run directly underneath this panel. No special cutouts or modifications are necessary.

Use the strain reliefs provided in the J-box to secure the power wiring.

Step 3

Locate the harness marked with the “MAIN POWER” label inside the junction box.

For 1 HP installations, see Figure 4-6 for a diagram illustrating how to connect the blower to power.

Figure 4-6

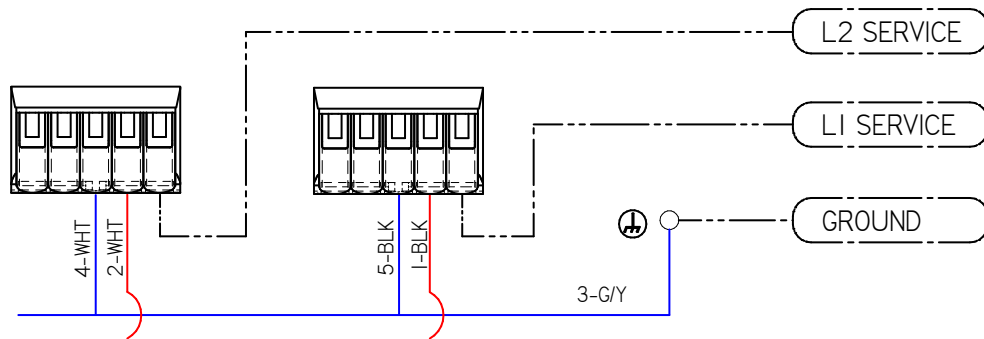

For 2 HP installations, single or three phase power must be determined



The 2HP VFD Motor Spectrum Blowers operates on either single or three phase power. To properly connect the blower to power, identify which phase power is available at the installation site and properly wire it based on the procedure below.

Incorrectly identifying and wiring the Blower can result in damage and/or inefficiency. Please ensure appropriate steps are taken to prevent mistakes.

Follow Figure 4-7 for a diagram illustrating how to connect the 2 HP blower to power.

Figure 4-7

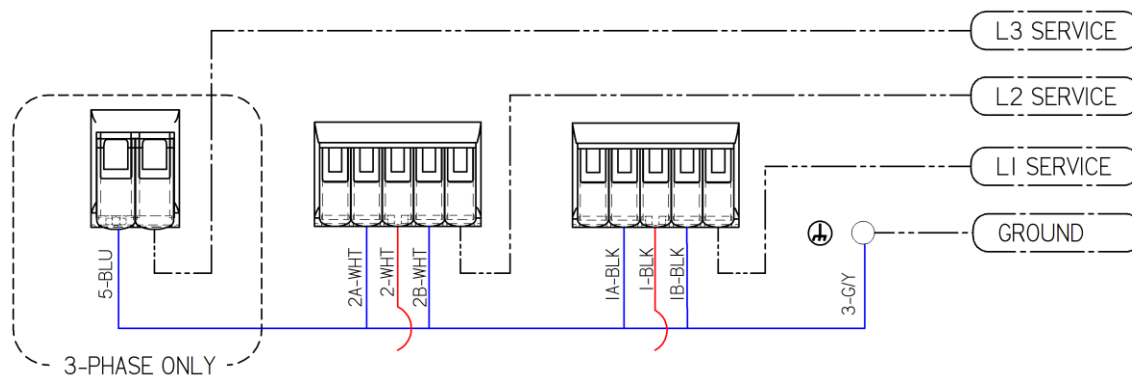

Step 4

If desired, a surge protector can be installed in the service line prior to the power wiring shown in Figures 4-6 & 4-7.

Any penetration of the building roof by electrical wiring/conduit must be sealed appropriately.

Step 5

Organize all wires and harnesses within the J-box and reinstall the J-box cover and weather cover previously removed.

AC Select Switch (For 100-125 VAC 1 HP ECM Only)

The 1 HP ECM Spectrum Blower is factory default rated at 208-250 VAC. If connecting to 100-125 VAC, the AC select switch needs be adjusted. If connecting to 208-250 VAC single-phase power, the AC select switch should not be adjusted.



Failure to match AC power to blower with this switch can cause damage to the motor. Do NOT adjust switch until you have confirmed AC power to the blower.

To locate the switch, remove either the access panel (reference Figure 6-1) or the weather cover. To prevent accidental change of the switch position it is covered with a bracket. Use the instructions on the switch panel as shown in Figure 4-8 to select the correct voltage.

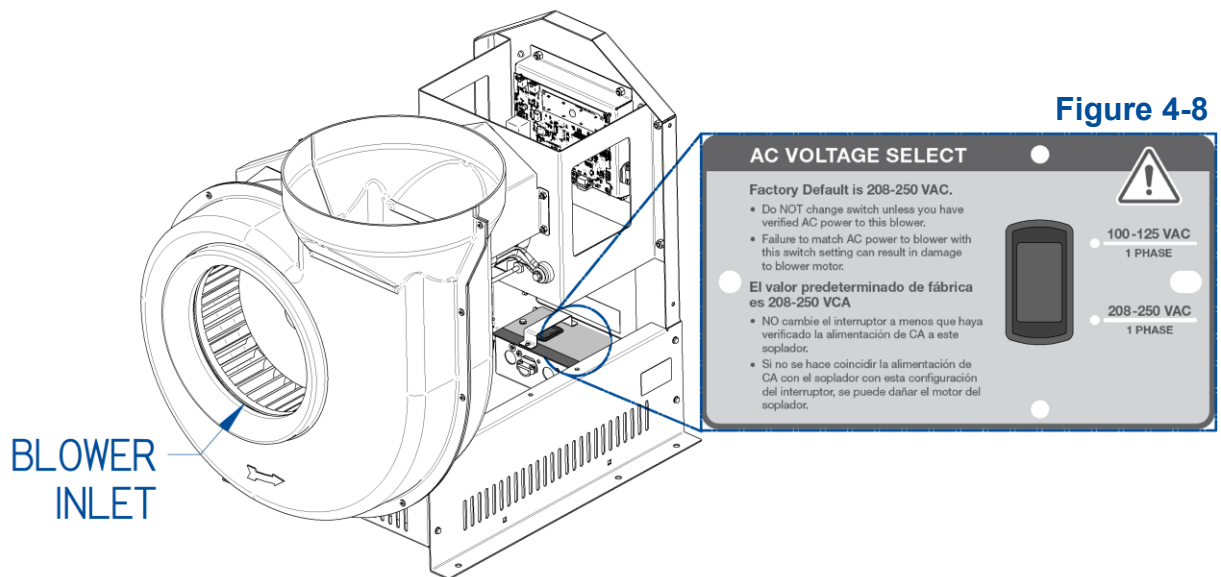

When the blower wiring has been completed, check for proper motor rotation. When in operation, the impeller should rotate counterclockwise when viewed from the blower inlet (Reference Figure 4-8).



This blower contains an electrical motor, which requires proper electrical connection per National Electrical Code to prevent hazards. The National Electrical Code and local codes may require that a circuit disconnect, overload protection, and short circuit protection be included in the installation. The unit should be connected by a licensed electrician.

Ce ventilateur contient un moteur électrique, ce qui nécessite une bonne connexion électrique par National Electrical Code de prévention des risques. Le National Electrical Code et les codes locaux peuvent exiger que la déconnexion du circuit, protection de surcharge, et la protection de court-circuit sont inclus dans l'installation. L'appareil doit être raccordé par un électricien agréé.

Connect PVC Drain (For PVC Blowers Only)

The PVC Blower has a 1/2" NPT drain connection in the bottom of the housing. When this connection is used, it should be directed into a proper drain or into the exhaust duct for proper disposal. Reference Figure 4-9.



Draining the blower housing directly onto the roof may cause damage to your roof due to the corrosive chemicals exhausted.

Vidange du carter de la soufflante directement sur le toit peut causer des dommages à votre toit en raison des produits chimiques corrosifs épuisés.

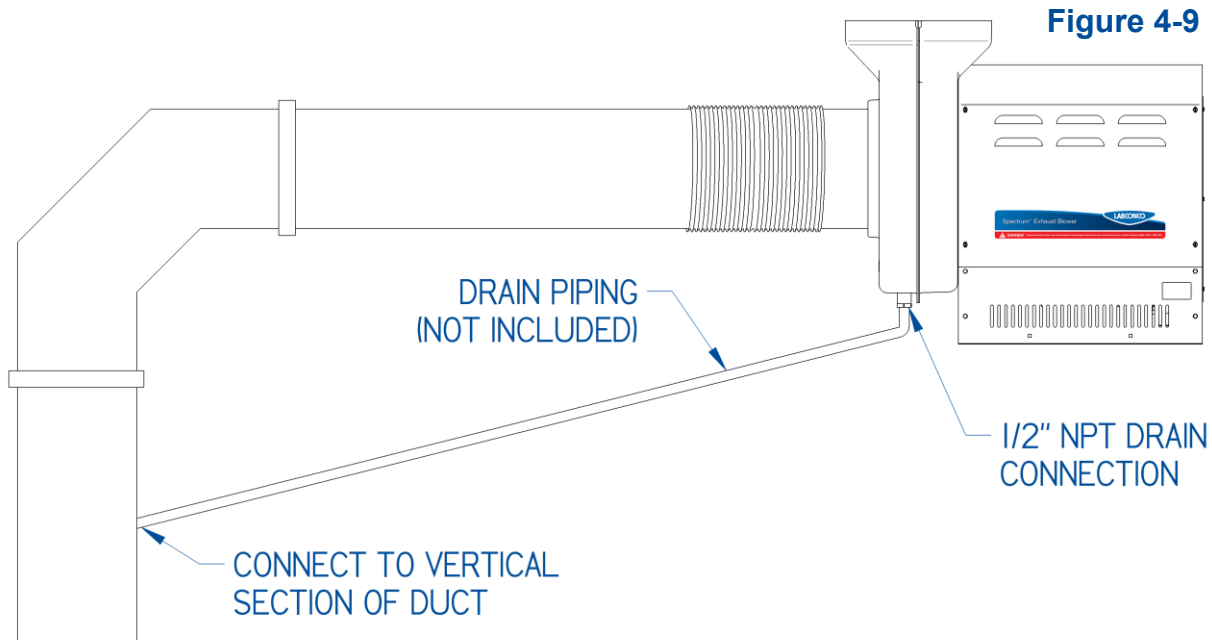

For information on setting the blower speed, see [Section 6: Spectrum Blower Fan Speed Operating Systems](#).

5: Performance Features

Spectrum Blowers are dedicated, adjustable laboratory exhaust blowers that maximize energy efficiency for exposure control device installations. These blowers are adjustable and optimized to succeed in most laboratory ventilation environments associated with fume hood and enclosure exhaust.

Built-in Vibration Isolation

In addition to using vibration dampers on the curb prior to blower installation, isolators are used to mount the motor within the blower housing.

ECM Motor & VFD Motor

An electronically commutated motor, or ECM, is up to 82% efficient and provide precise airflow control. A variable frequency drive, or VFD, motor is controlled by changing the applied frequency signal. The VFD motor is well known for energy-saving performance and ease of speed control. These technologies offer superior operating life compared to PSC motors.

Traditional AC belt-drive blowers typically have two speeds: on and off. There are no belts or sheaves to change or set the desired operating speed/airflow.

Multiple Input Control Options

Building Management Systems, or BMS, can control and monitor HVAC and similar ventilation systems. The Spectrum Blower can be controlled by a BMS signal. Both 4-

20mA and 0-10 VDC input options are standard. Once properly connected, the speed of the blower is set and controlled through the input chosen. If multiple Spectrum Blowers are installed, the BMS inputs can be used to control each Spectrum Blower from one BMS interface.

If not controlling the Spectrum blower using a BMS input, there is an on-board potentiometer on every Spectrum Blower. To adjust the blower, a small screwdriver adjusts the potentiometer to set the speed needed for each installation.

See [Section 6: Spectrum Blower Fan Speed Operating System](#) for detailed information on how to prepare and control the blower for every input option available.

Data Output

The Spectrum Blower features both RS-232 & RS-485 data outputs as standard. Using the outputs provided, the following data can be monitored and logged:

1. Blower Status
2. Motor RPM
3. Internal Temperature (°C)
4. Alarms (if any)
5. Control Selection (on board pot, 0-10V signal, or 4-20mA signal)

The data output is also stored locally in the Spectrum Blower for up to 30 days. To download the data log manually, see [Section 7: Performance Data Download Log File](#) for protocol.

Temperature Monitoring

The internal temperature of the Spectrum Blower is recorded and monitored. Using this data, the motor can self-protect if the temperature is above or below safe operating conditions. Temperatures are also recorded in the performance data log for troubleshooting/diagnosis. If applicable, the temperature alerts and data will be communicated through the BMS connection via RS-232 or RS-485 protocol.

Universal Operating Voltage

The 1 HP ECM Spectrum Blower comes in two universal operating voltages: 115V single phase & 230V single phase. The 2 HP VFD Spectrum Blower operating voltage is 230V in single or three phase power input. See [Appendix C: Specifications](#) for more information on the Power Data for both motors.

On Board USB Port

Allows easy field update of software and download of performance data log. Requires a flat head screwdriver to remove four screws and panel to access USB. 30 days of performance logging can be retrieved from this USB port to aid in troubleshooting. For instructions on how to update software, see [Section 7: Using your Spectrum Blower](#).

Switched Relay Output

A low current switched contact on the Spectrum allows remote monitoring of the Spectrum status, if desired. The contact closes when the blower is on and no alarms are active. For instructions on communicating the Spectrum status via a Guardian Digital Airflow Monitor see [Appendix E: Connecting the Spectrum Blower to a Guardian Digital AFM \(Airflow Monitor\)](#).

6: Spectrum Blower Fan Speed Operating System

The Spectrum Blower operating system provides user control and useful information with the display screen and keypad. In this section, connecting the blower to a remote ON/OFF switch, choosing control options, setting the speed of the blower, and certification details will be explained.

Control panel

Access controls by removing the six screws holding the panel in place with a flat head screwdriver or 5/16" nutdriver as shown in Figure 6-1. Keep this hardware. See Figure 6-2 to navigate the control panel as described in the rest of this section.

Determine if the Spectrum Blower is to be controlled by the on-board potentiometer (blower will operate at set speed continuously), or with a 0-10V or 4-20mA signal.

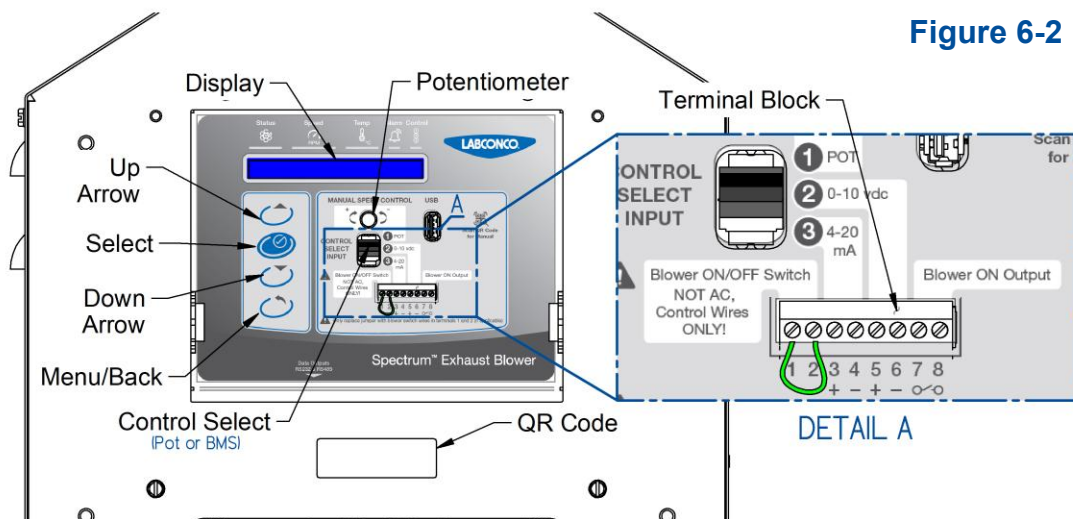
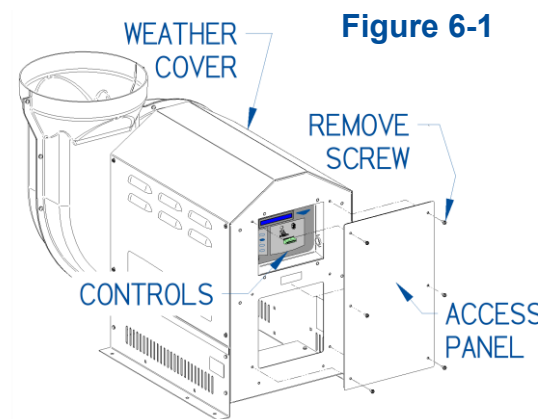

Remote Blower ON/OFF Switch

If remote ON/OFF operation is required, a switch to control the blower must be installed at the desired point of control. For fume hood applications, the switch, as shown in Figure 6-3, is commonly installed on the fume hood's corner post. If not using a remote switch to control the blower or if 24/7 operation is required, proceed to the correct section according to the desired input control signal.

 Labconco strongly recommends using 22 gauge of shielded cable with drain wire for the control wires. Using shielded cable will limit interference along the path the cables are ran.

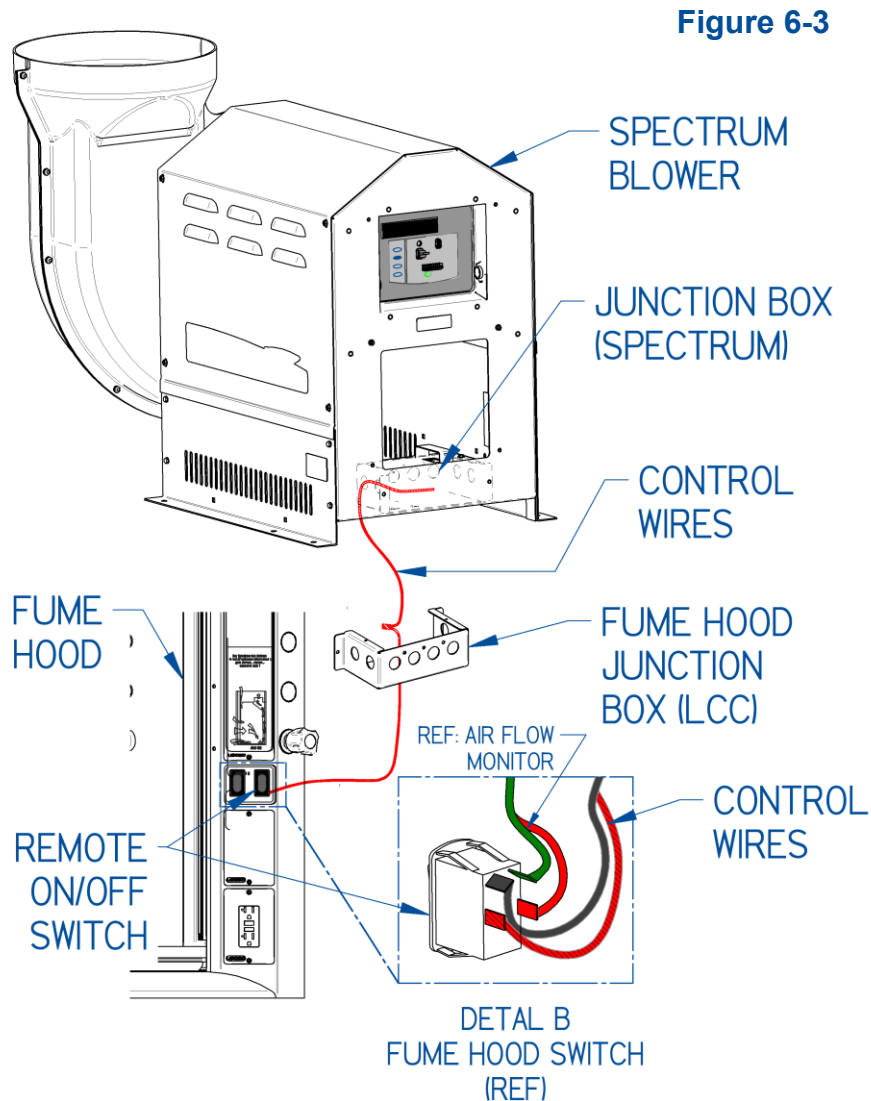

AC Powered Remote Blower Switch Only:

If installing using DC power, skip to the next section. If installing using AC Power, find the AC Power origins you're using and then proceed through the remaining steps.

Originating from the Blower (Recommended):

Step 1

Run two lines of control wires from the Spectrum Blower's junction box to the Fume Hood. For Labconco fume hoods, the blower ON/OFF switch wires are run to the junction box located on the top of the hood. Reference Figure 6-3. The wires must run through strain reliefs in the fume hood and Spectrum junction boxes.

Step 2

Inside the Spectrum Junction box, locate the harness branches originating at the relays. The branches are labeled with tags: "FUME HOOD SWITCH 115V" and "FUME HOOD SWITCH 230V". Install the user-supplied control wires running from the fume hood switch into the correct relay 2-place lever connector based on voltage rating of the AC power on the fume hood. Reference Figure 6-4a.

Remove the sister connector (Orange if used purple, and Yellow if used Gray) and connect that wire to the L2 service 5-place lever connector. Reference Figure 6-4a.

Install the user-supplied control wires running to the fume hood switch into the correct relay 5-place lever connector as shown in Figure 6-4a.

Figure 6-4a

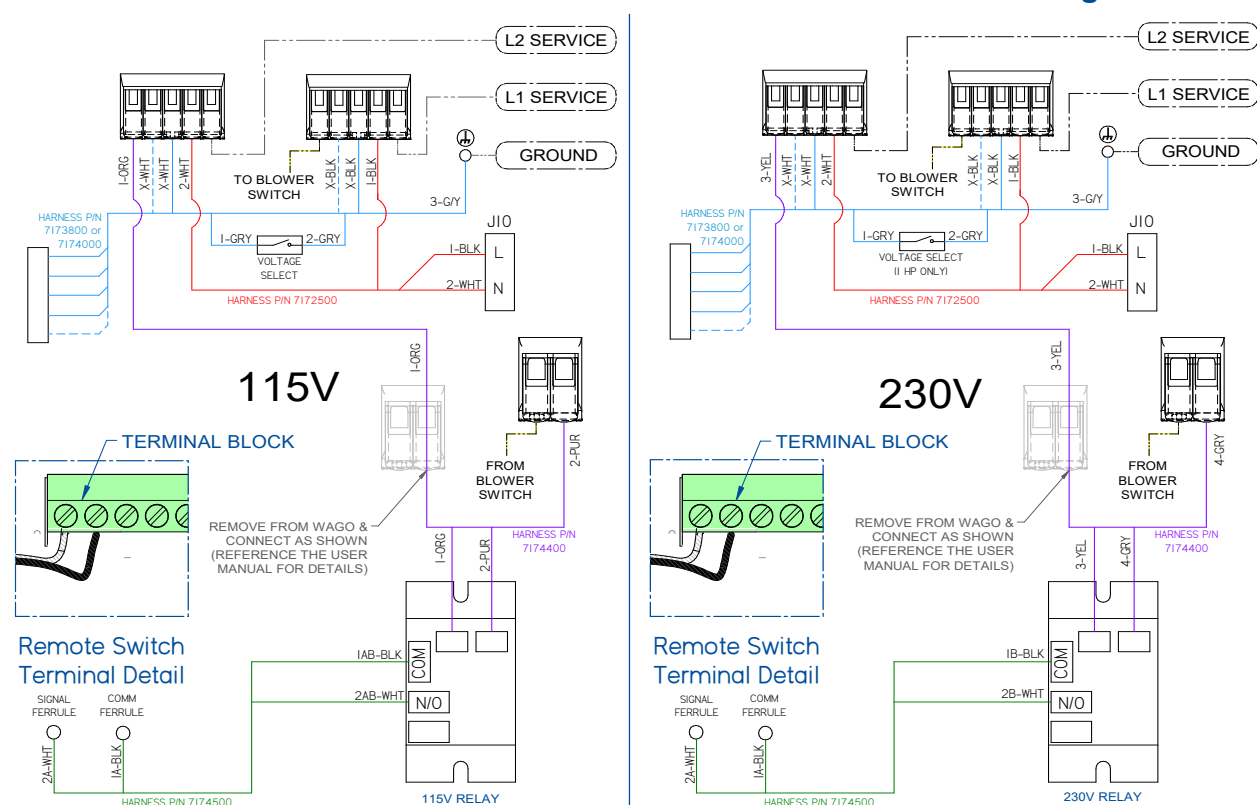

Proceed to Step 3.

Originating from the Fume Hood:

Step 1

Control wires must be run from the remote switch installed on the fume hood to the roof-top blower. For Labconco fume hoods, the blower ON/OFF switch wires are run to the junction box located on the top of the hood. From the hood, it is recommended the wires are run to the Spectrum Blower junction box as shown in Figure 6-3. The wires must run through strain reliefs in the fume hood and Spectrum junction boxes.

Step 2

Inside the Spectrum Junction box, locate the harness branches originating at the relays shown in Figure 6-4b. The branches are labeled with tags: “*FUME HOOD SWITCH 115V*” and “*FUME HOOD SWITCH 230V*”. Install the user-supplied control wires into the correct relay lever connector based on voltage rating of the AC power on the fume hood.



AC power of the fume hood switch may differ from the Spectrum’s supplied voltage.

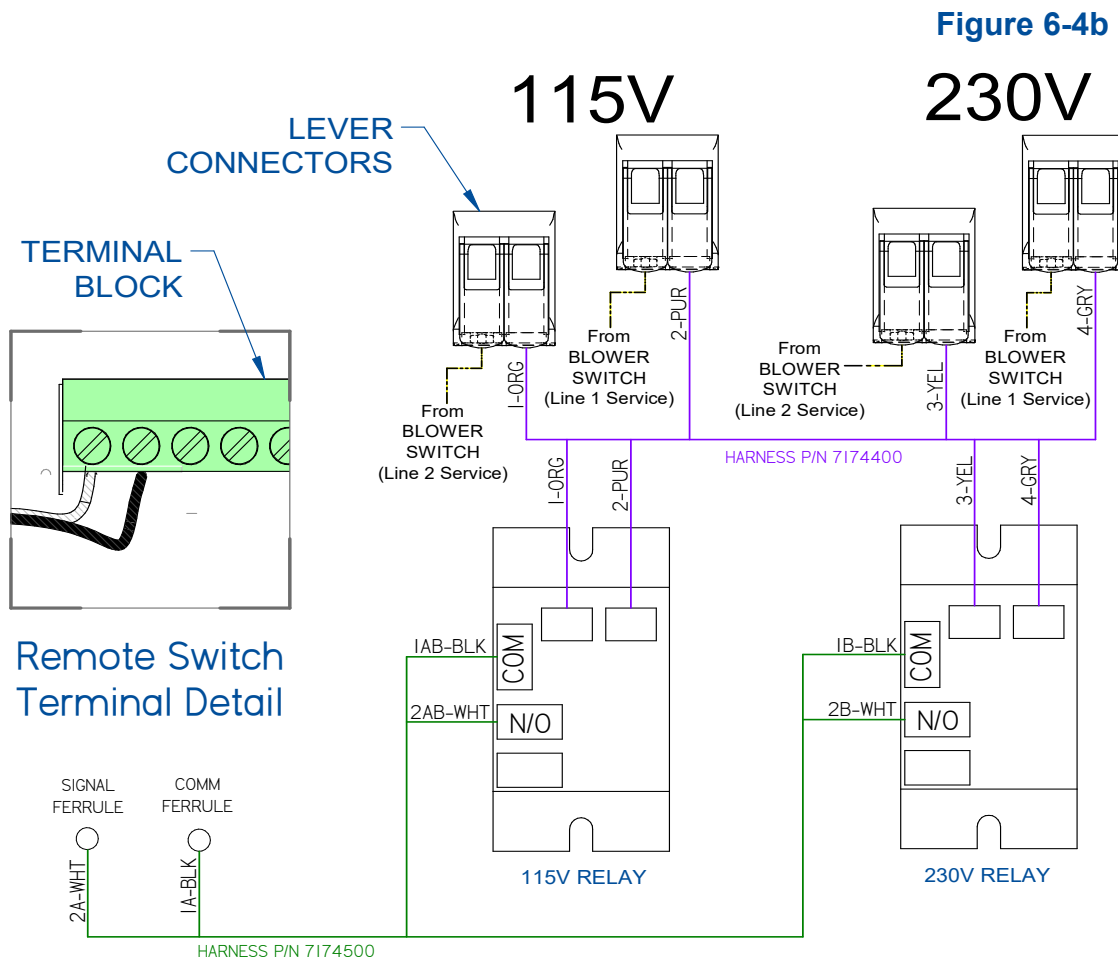

Proceed to Step 3.

Step 3

Remove and replace the green jumper wire that came factory installed in terminals 1 & 2 with the control wires labeled “*CONTROL WIRES to terminals 1 & 2*” as shown in Remote Switch Terminal Detail of Figure 6-4b. Install the white signal ferrule into terminal 1 and the black comm ferrule into terminal 2. The terminal block can be removed and reinstalled for easier wire installation.



Do NOT run AC power into the terminal block of the Spectrum controls. Terminals are rated for 12vdc at 1 Amp max. Running high current to the Spectrum through any of the terminals will cause damage to the Spectrum Blower that is not covered under warranty.



If 24/7 or BMS controlled with 0-10vdc or 4-20mA signal operation is required, do not remove the jumper of terminals 1 & 2. Jumper is only removed to add a remote ON/OFF switch.

DC Powered Remote Blower Switch Only:



Labconco strongly recommends using 22 gauge of shielded cable with drain wire for the control wires. Using shielded cable will limit interference along the path the cables are ran.

Step 1

Control wires must be run from the remote switch installed on the fume hood to the roof-top blower. For Labconco fume hoods, the blower ON/OFF switch wires are run to the junction box located on the top of the hood. From the hood, it is recommended the wires are run to the Spectrum Blower junction box as shown in Figure 6-3. The wires must run through strain reliefs in the fume hood and Spectrum junction boxes.

Step 2

Remove and replace the green jumper wire that came factory installed in terminals 1 & 2 with the user-supplied shielded wires as shown in Figure 6-5. The terminal block can be removed and reinstalled for easier wire installation.

Ignore the “*CONTROL WIRES to terminals 1 & 2*” taped under the controls if utilizing DC power for the control wires.



Do NOT run AC power into the terminal block of the Spectrum controls. Terminals are rated for 12vdc at 1 Amp max. Running high current to the Spectrum through any of the terminals will cause damage to the Spectrum Blower that is not covered under warranty.



If 24/7 or BMS controlled with 0-10vdc or 4-20mA signal operation is required, do not remove the jumper of terminals 1 & 2. Jumper is only removed to add a remote ON/OFF switch.

Figure 6-5

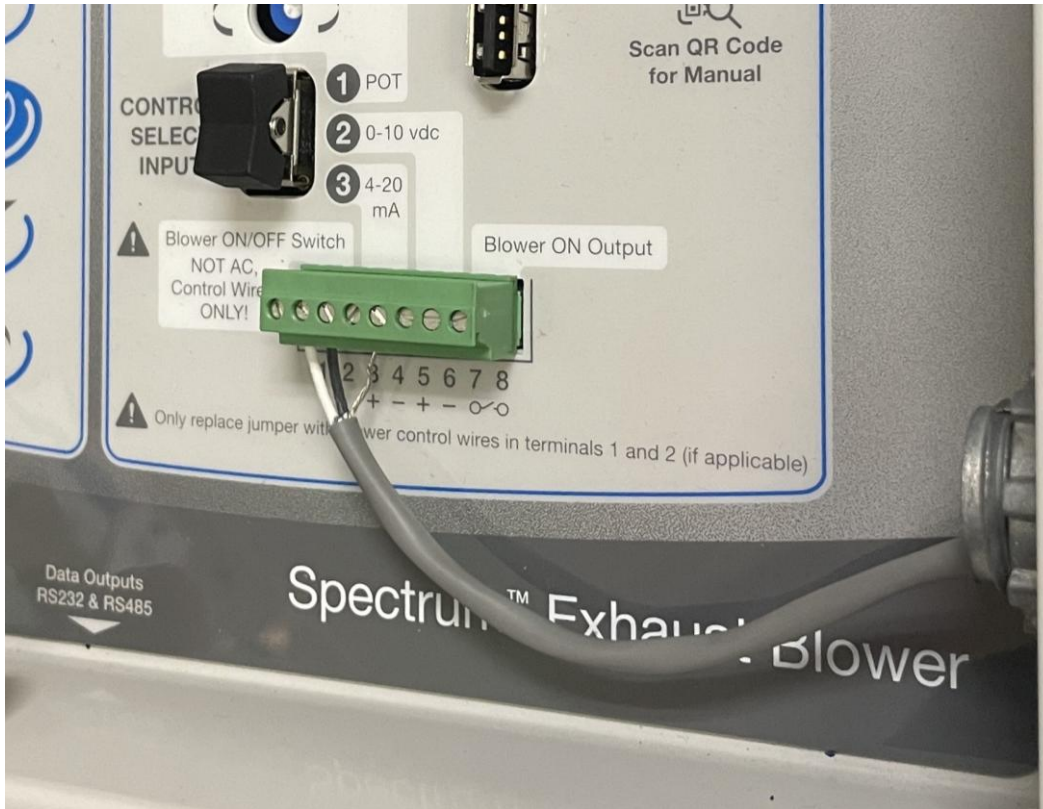

Step 3

Connect the shield drain (Reference Figure 6-5) from the control wires into terminal block position based on intended speed control:

- If planning to control the speed via the On-Board Potentiometer, position 4 or 6 can be utilized.
- If planning to control the speed through 0-10Vdc Input, connect the shield drain to position 4.
- If planning to control the speed through 4-20mA Input, connect the shield drain to position 6.

On-Board Potentiometer

The Blower fan speed needs to be adjusted in the field to achieve the required volumetric rate (airflow). To adjust the blower to the proper speed using the potentiometer, follow the procedure below.



Do not operate the blower at maximum speed unless airflow has first been certified and verified by a qualified certification company. Operating the blower at full speed without proper airflow verification may result in excessive static pressure within the duct system, which can cause the blower to overheat. In this condition, the blower will automatically reduce speed to protect the unit.

Step 1

Ensure the blower is connected to AC power at the roof and the control panel is uncovered as seen in Figure 6-2. Control select should be set to option 1 'POT'. Double check on the display that **Control** (or the final value) reads '1'.

Step 2

Set the remote blower switch (if applicable) to its ON position before manipulating the on-board potentiometer.

Step 3

Locate the potentiometer on the control panel as seen in Figure 6-2. With a small jeweler screwdriver, adjust the potentiometer setting and measure airflow. Readjust the potentiometer setting as required to set the desired airflow. Allow a few seconds for the motor to achieve steady state speed after every adjustment.



Clockwise rotation increases the blower speed and corresponding airflow (CFM) increase. If setting fume hood face velocity, use a thermal anemometer at the hood face at required sash height to confirm required airflow.

Step 4

Verify airflow per the user's needs.



If not operating in the safe area of the Blower Curve, a manual damper is often used in the exhaust ducting just before the blower inlet for fine tuning and operating in the proper portion of the blower airflow chart. For lower airflow volume (CFM) at any RPM, close the damper. Refer to [Appendix D: Blower Curves](#) that shows a typical blower operating curve with the damper adjusted to different positions.

0-10Vdc Input

The speed of the blower can be set using the 0-10 vdc setting. If controlling the ON/OFF of the blower with the 0-10V signal, ensure jumper is present in terminals 1 & 2 (as shown in green in Detail A of Figure 6-6). The blower will turn off at any signal between 0V to 1V.



Do not operate the blower at maximum speed unless airflow has first been certified and verified by a qualified certification company. Operating the blower at full speed without proper airflow verification may result in excessive static

pressure within the duct system, which can cause the blower to overheat. In this condition, the blower will automatically reduce speed to protect the unit.

Step 1

Ensure the blower is connected to AC power at the roof and the control panel is uncovered as seen in Figure 6-6. Control select should be set to option 2 '0-10 vdc'. Double check on the display that **Control** reads '2'.

Step 2

Control wires must be installed in terminals 5 & 6. Run these wires through the strain reliefs in the control panel area before routing through the building. Connect the control wires to the 0-10 vdc signal source (typically a BMS control system). If not using a remote ON/OFF switch, do NOT remove the jumper as shown in Figure 6-6.

Figure 6-6

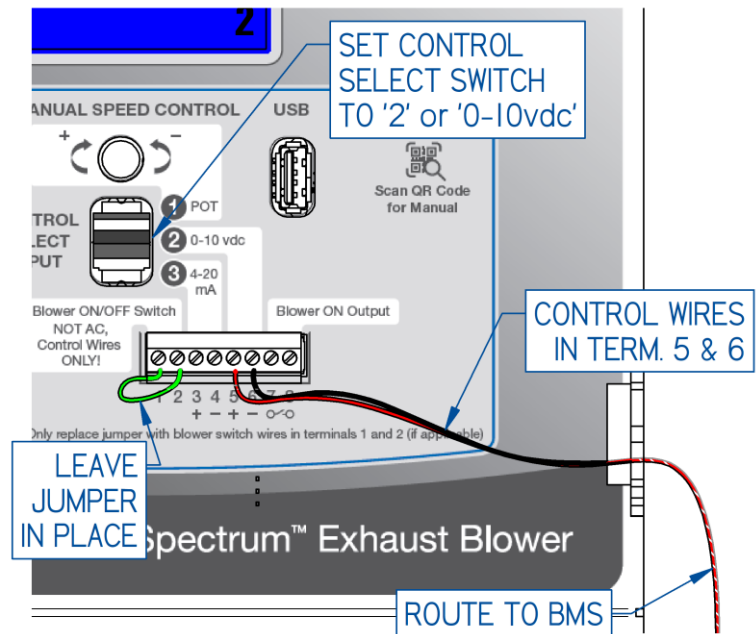

Labconco strongly recommends using 22 gauge of shielded cable with drain wire for the control wires. Using shielded cable will limit interference along the path the cables are ran.

Step 3

Using the 0-10vdc signal, the speed of the Spectrum Blower can be adjusted. Adjust the speed setting by varying the 0-10 vdc signal and measure the airflow. Readjust the voltage signal as required to set the airflow. Allow a few seconds for the motor to achieve steady state speed after every adjustment. See [Appendix D: Blower Curves](#) for suggested signal settings based on desired RPM or CFM.



To prevent electrical noise from starting the blower when it is desired off, an input from 0V to 1V will be considered off. Between 9 and 10V signal is considered the maximum speed so signal loss will not prevent the blower from reading maximum speed.

Step 4

Verify airflow per the user's needs.

 If not operating in the safe area of the Blower Curve, a manual damper is often used in the exhaust ducting just before the blower inlet for fine tuning and operating in the proper portion of the blower airflow chart. For lower airflow volume (CFM) at any RPM, close the damper. Refer to [Appendix D: Blower Curves](#) that shows a typical blower operating curve with the damper adjusted to different positions.

4-20mA Input

The blower speed can be set using a 4-20mA signal. If controlling the ON/OFF of the blower with the 4-20mA signal, ensure jumper is present in terminals 1 & 2 (as shown in green in Figure 6-7).



Do not operate the blower at maximum speed unless airflow has first been certified and verified by a qualified certification company. Operating the blower at full speed without proper airflow verification may result in excessive static pressure within the duct system, which can cause the blower to overheat. In this condition, the blower will automatically reduce speed to protect the unit.

Step 1

Control wires must be installed in terminals 3 & 4. Run these wires through the strain reliefs in the control panel area before routing through the building. Connect the control wires to the 4-20mA signal source (typically a BMS control system). If not using a remote ON/OFF switch, do NOT remove the jumper as shown in Figure 6-7.

 Labconco strongly recommends using 22 gauge of shielded cable with drain wire for the control wires. Using shielded cable will limit interference along the path the cables are ran.

Figure 6-7



Step 2

Ensure the blower is connected to the power at the roof and the control panel is uncovered as seen in Figure 6-7. Control select should be set to option 3 '4-20mA'. Double check on the display that **Control** reads '3'.

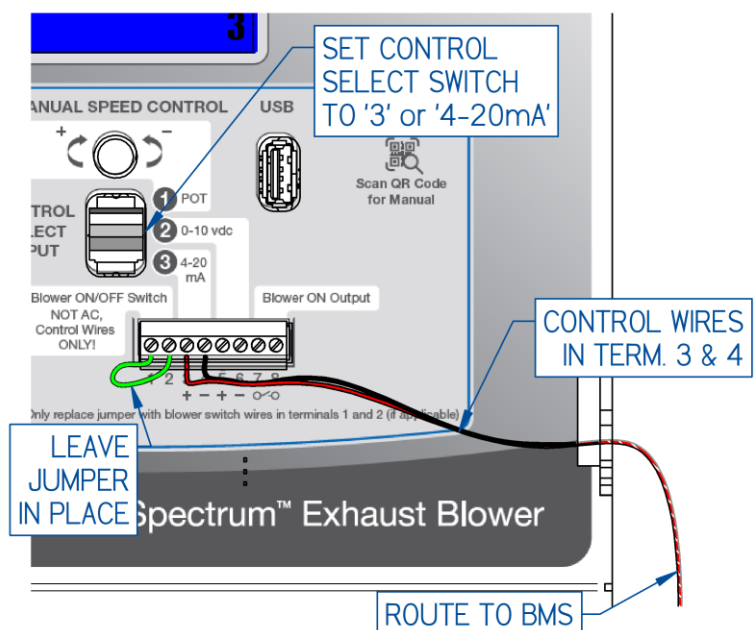
Step 3

Using the 4-20mA signal, the speed of the Spectrum Blower can be adjusted. Adjust the speed setting by varying the 4-20mA signal and measure the airflow. Readjust the amperage signal as required to set the airflow. Allow a few seconds for the motor to achieve steady state speed after every adjustment. See [Appendix D: Blower Curves](#) for suggested signal settings based on desired RPM or CFM.

Step 4

Verify airflow per the user's needs.



If not operating in the safe area of the Blower Curve, a manual damper is often used in the exhaust ducting just before the blower inlet for fine tuning and operating in the proper portion of the blower airflow chart. For lower airflow volume (CFM) at any RPM, close the damper. Refer to [Appendix D: Blower Curves](#) that shows a typical blower operating curve with the damper adjusted to different positions.

7: Using Your Spectrum Blower

This section details the functional features and proper techniques for safely and efficiently using the Spectrum Blower.

Control Display

Figure 7-1

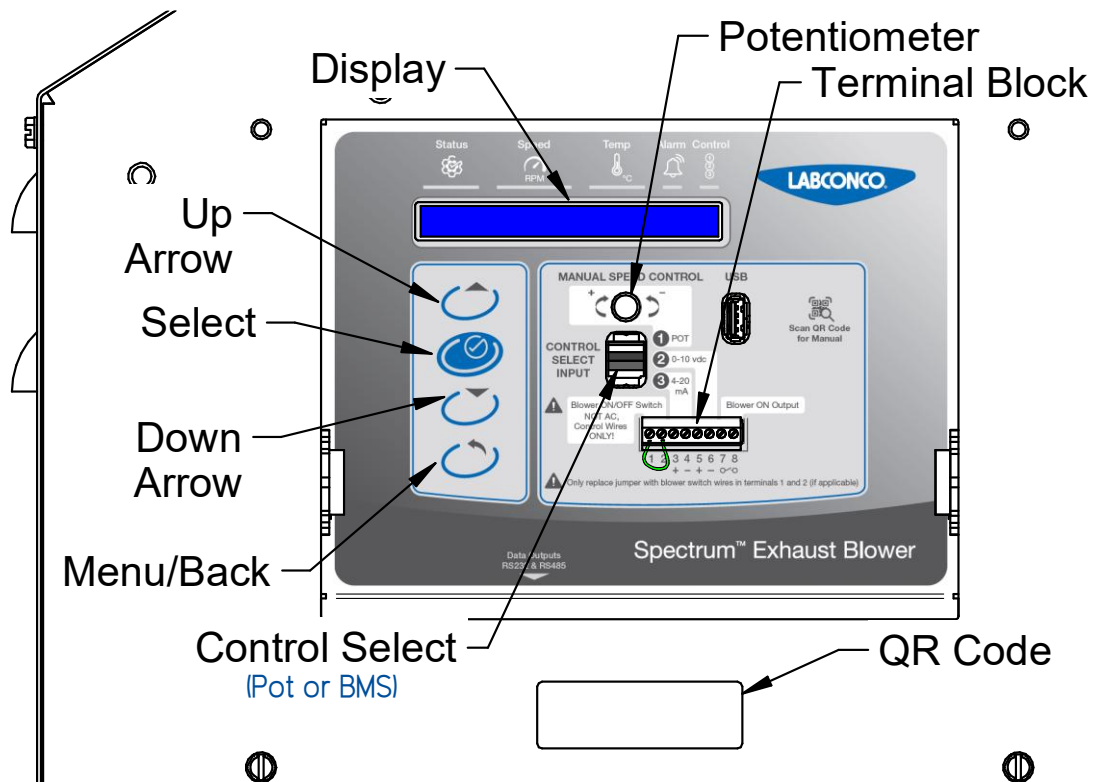

Data Outputs

The Spectrum Blower provides both RS-232 & two-wire RS-485 data outputs as follows. Using the outputs provided, the following data can be monitored and logged:

1. Blower status
2. Motor RPM
3. Internal Temperature (°C)
4. Alarms (if any)
5. Control Selection (on-board pot, 0-10V, or 4-20mA)

To receive data output, locate the RS-232 or RS-485 ports. Using a 5/16" nut driver, remove the 6 screws holding the weather cover in place and pull it off the motor housing. On the back side of the control board the data output ports can be located pointing down as shown in Figure 7-2 (the control label can be used as a location indicator as well). Using the appropriate cable, connect the BMS to the RS-232 or RS-485 and confirm the data is being received.

Communication Protocol:

Parameters	RS-232	RS-485
Baud Rate	9600	9600
Data Bits	8	8
Parity	None	None
Stop Bits	1	1
Flow Control	None	None
Endian	LSB	LSB

Menu Navigation

See Table 7-1 in this section for the default values of each setting. Updating software and downloading data is also detailed in this section. To browse the menu options, use the keypad shown in Figure 7-1. Press **[MENU/BACK]** to access the main menu and scroll through the options using the **[UP ARROW]** and **[DOWN ARROW]**.

Settings

Motor Configuration

This programmed menu option must match the physical motor installed in the Spectrum Blower.



Do not change the motor configuration setting of the Spectrum Blower unless it is confirmed to be programmed differently from the physical configuration. See Figure 7-2 to see the physical configuration of both the 1 HP motor and the 2 HP motor without the weather cover installed.

Figure 7-2

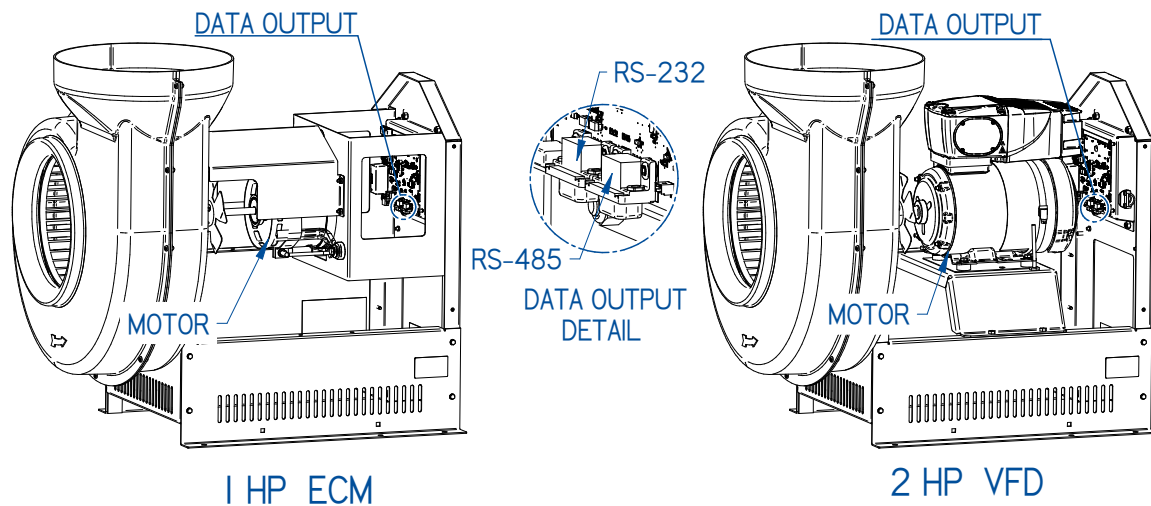

Locate 'CONFIGURE' in the menu, press **[SELECT]**. You will be prompted to choose the motor configuration between the two options '1 HP' and '2 HP'. Do this quickly or the blower will return to the main display. Once the motor size is correctly shown, press **[SELECT]**.

If the motor configuration selected matches the previous setting, the display will read 'SET TO X HP' and return to the main display.

If the motor configuration selected does not match the previous setting, the display will prompt 'CHANGE TO X HP?'. Ensure the selection is correct and press **[SELECT]**. This step must be done within 30 seconds, or the display will return to the main menu.

Once the motor configuration has been confirmed, the display will read 'SET TO X HP' and return to the main display.

Alarms

There are three alarm settings that can be modified:

- Delay time of alarms
- Minimum RPM alarm
- Alarm temperature

Default values of these settings can be seen in Table 7-1. Follow the steps below to change these settings.

Delay Time of Alarms

There is a delay between alarm condition(s) and alarm warning(s). The default value for this setting is 30 seconds. The purpose of this delay is to limit nuisance alarms by delaying the alarm warning after the conditions for alarms are met. If the problem resolves itself within this delay time, the alarm will not appear.

Locate the 'ALARM DELAY TIME' option in the menu, press **[SELECT]**. You will be prompted to choose the new time increment. The available range is *10 seconds to 180 seconds* in 10 second increments. Once the preferred rate is found, press **[SELECT]**. The screen will read 'SET TO XXX SEC' and return to the main display.

Minimum RPM Alarm

There is an alarm condition triggered when the motor runs at a low RPM. The default value for this setting is 300 RPM. The purpose of this warning is to notify the user when the blower is not operating properly. The alarm condition is met when the Spectrum Blower speed is less than this value (i.e. 300 RPM).

Locate 'MIN RPM ALARM' option in the menu, press **[SELECT]**. You will be prompted to choose the new minimum speed alarm threshold. The available range is *300 RPM to 600 RPM* in 50 RPM increments. Once the preferred speed is selected, press **[SELECT]**. The screen will read 'SET TO XXX RPM' and return to the main display.

Alarm Temperature

There is an alarm condition when the internal temperature exceeds a specific threshold. The default value for this temperature is 52°C (or approx. 125°F). The purpose of this warning is to protect the motor from running at a temperature that could cause damage to the blower or motor.

Locate 'ALARM TEMP' option in the menu, press **[SELECT]**. You will be prompted to choose the new alarm temperature value. The available range is *37°C to 94°C* in 1°C increments. Keep in mind, the temperature values being used by the Spectrum Blower are all in Celsius and not Fahrenheit. Once the preferred temperature is displayed, press **[SELECT]**. The screen will read 'SET TO XX C' and return to the main display.

Data Log Rate

Data performance logs are stored in the Spectrum and are downloadable for troubleshooting and monitoring purposes. The default is 10 seconds, which logs data every 10 seconds. At a 10 second log rate, the Spectrum can store approximately 30 days of data at a time. After 30 days, the oldest log file will be deleted and rewritten with the newest data. If using a 30 second log rate, the spectrum can store approximately 90 days of data. If the log rate is at the maximum 600 seconds (10 minutes), the storage data wouldn't be rewritten for 1,800 days. To change the log rate, follow the instructions below:

Locate the 'LOG RATE' option in the menu, press **[SELECT]**. You will be prompted to choose the new rate increment. The available range is *10 seconds to 600 seconds* in 10 second increments. Once the preferred rate option is found, press **[SELECT]**. The screen will read 'SET TO X SEC' and return to the main display.

Factory Reset

After making changes to the Spectrum Blower settings, the factory defaults can be restored at any time. The default values for the Spectrum Blower can be seen in Table 7-1 in below.

To achieve a factory reset, scroll through the menu options and press **[SELECT]** when you find 'FACTORY RESET'. User must press **[SELECT]** again when prompted 'CONFIRM RESET?' to return settings to the default values. Do this step in 30 seconds or the display will return to the main menu.

Once the reset is completed, the blower will return to the main display and settings will match Table 7-1.

Default Values

From the factory, the Spectrum Blower settings will be as stated in Table 7-1.

Table 7-1

Setting Description	Default Value
Alarm Delay Time	60 Seconds
Minimum RPM Alarm	300 RPM
Alarm Temperature	52°C
Data Log Rate	10 Seconds

*Motor configuration is the only setting the factory reset will NOT change.

Performance Data – Download Log File

The data performance log is downloadable for trouble shooting and monitoring purposes. The data in the performance log is the same data exported to the BMS RS-232/485 ports (Status, RPM, Temperature, etc.).



To download the performance data of the Spectrum Blower, a blank USB/Flash Drive is needed.

Locate the 'LOG FILE' option in the menu, press **[SELECT]**. You will be prompted to 'INSERT USB' into the USB Port. Do this within a minute or the software will return to the main display. Once the USB is inserted correctly, the display will read 'DOWNLOADING'. Leave USB in the port until the display reads 'DONE' and returns to the main display.



Record the log rate, date, and time when the log file is downloaded. Use this information when reviewing the performance data.

Remove the USB. The data can be viewed using any USB compatible device (i.e. PC).

Software Update

To perform a software update on the Spectrum blower, follow the steps below.



To update the software for the Spectrum Blower, the appropriate .hex file needs to be on a flash drive ready for use. To get this file, go to the Spectrum Blower product page on Labconco.com or use the QR code on the product and follow the instructions for downloading the firmware package.

Once the package is downloaded, two files will be found. The .pdf is instructions to update the firmware. The .hex file is the firmware. *This file must be put on a USB flash drive before proceeding with the following steps.*



Updating the software in the Spectrum Blower will result in the permanent deletion of all data logs stored in the blower. Export data logs prior to updating if needed. See [Performance Data-Download Log File](#) in this section for more information.



If power is lost during the update process contact Labconco, as the blower will likely be inoperable.

After finding the 'UPDATE' option in the menu, press **[SELECT]**. You will be prompted to 'INSERT USB' into the USB Port. Do this within a minute or the software will return to

the main display. Once the USB is inserted correctly, the display will read 'UPLOADING'. Leave USB in the port for this step. It is important to not interrupt the process of uploading the data from the USB. Finally, press [SELECT] when display changes to 'READY TO UPDATE?'. Do this quickly or the Spectrum Blower will return to the main display.

Once successfully done, the blower software will update. The display will return to the main display and the USB may be removed.

Alarm Contact (Blower ON Contact)

When the blower is desired on and in any alarm condition, the contact of terminals 7 & 8 will open. Once no longer experiencing an alarm condition, the contact will close again. If more than one condition is in alarm, the contact will not close until all alarms are resolved.



Never run high current through this contact.
The contact is only rated for 12 vdc at 1 Amp max.

See [Appendix E: Connecting the Spectrum Blower to a Guardian Digital AFM](#) to have an alarm state communicated through the Blower ON Contact to the airflow monitor. Fume hood user will see 'External Alarm' on the AFM once the contact opens and know to investigate the Spectrum Blower.

8: Maintaining Your Spectrum Blower

This section details the maintenance required for optimal operation of the Blower.

Maintenance Safety Precautions



The following tools and supplies are required to maintain the equipment:

- 5/16" Nut Driver
- Allen Wrench Set



The following safety precautions must be followed by all personnel maintaining the equipment.

- Wear safety glasses, and/or additional eye and face protection as required by your Health & Safety Department.
- Wear gloves, and/or additional skin protection as required by safety instructions for cleaning/disinfecting chemicals used. Consult your Health & Safety Department for additional skin protection requirements.
- No loose fitting clothes
- Wear close-toed shoes
- Although the service operations detailed in this section do not involve access to areas of the product with moving or electrical parts, should you remove any panels that expose moving or electrical parts, you must follow these instructions before doing so:
 - Disconnect main power cord or electrical service connection
 - Never touch moving parts such as fan blades or blower wheels.



Recommended Maintenance Schedule

Table 8-1

Activity	Maintenance Frequency		
	Weekly	Monthly	Annually
Shaft coupler to be inspected. Loosening of screws would indicate possible misalignment/unbalanced blower wheel			•
If blower is supporting an exposure control device (i.e. fume hood, BSC, etc.) it should be recertified as required, validating proper airflow			•

Service Operations

See [Appendix A: Parts List](#) for replacement parts.

Pillow Block Bearing Replacement

If the pillow block bearing needs replacement, make sure that the locking collars on the bearings face one another. The set screws used on the locking collars have been sealed with a removable thread sealant. Thread sealant should be applied when a pillow block bearing is replaced in the field.

Motor Replacement



The following tools are required to replace the motor:

- 5/16" nut driver
- Flathead screwdriver
- 7/16" socket and ratchet
- 7/16" wrench
- Allen wrench set
- 3/8" nut driver



The following safety precautions must be followed by all personnel maintaining the equipment.

- Wear safety glasses, and/or additional eye and face protection as required by your Health & Safety Department.
- Wear gloves, and/or additional skin protection as required by safety instructions for cleaning/disinfecting chemicals used. Consult your Health & Safety Department for additional skin protection requirements.
- Disconnect main power cord or electrical service connection
- Never touch moving parts such as fan blades or blower wheels

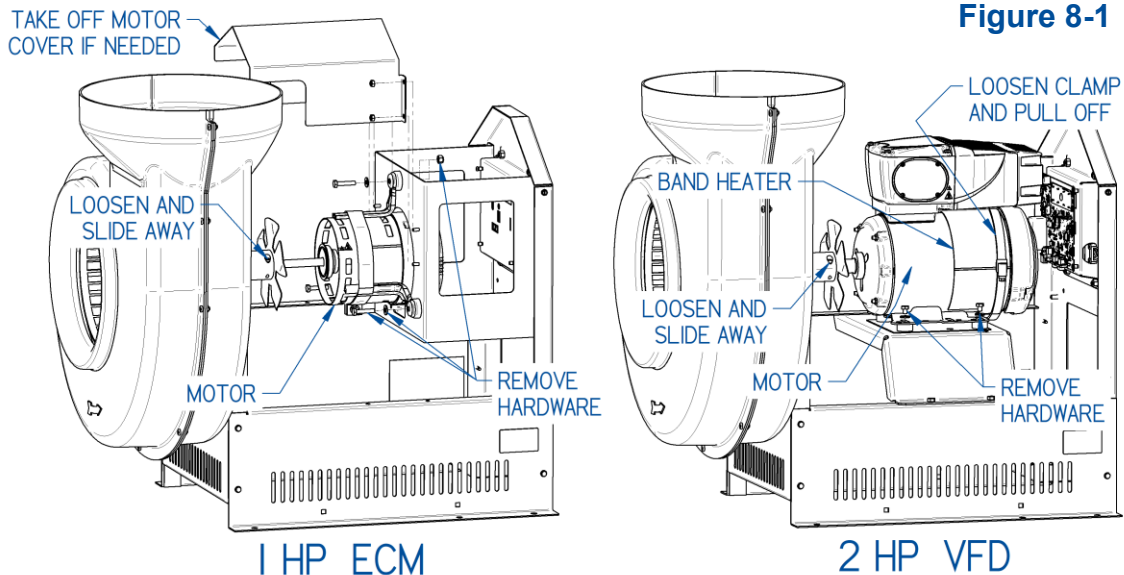

Figure 8-1

Step 1

With the power disconnected, remove the 6 screws securing the weather cover using a 5/16” nut driver or flathead screwdriver (shown in Figure 4-1). Save this cover and hardware.

Step 2 (For the 1 HP only)

If needed, use a 3/8” nut driver and remove the 4 nuts that keep the motor cover in place. Pull the motor cover away to expose the bolts mounting the 1 HP motor as shown in Figure 8-1. Save this cover and hardware.

Step 3

Loosen the coupling with the allen wrench set just enough to slide the coupling. Slide towards the blower housing until the coupling is completely off the motor shaft.

Step 4

Take note of how the motor harness is connected prior to removal. Remove the wire connectors to the motor and carefully set aside. The harness will be reconnected to the replacement motor later.

Step 5 (For the 2 HP only)

The band heater must be removed from the motor being replaced. Using a flat head screwdriver, loosen the band clamp enough to slide off the back of the motor. Unwrap the heater carefully and pull away from the motor. Save the heater and the clamp.

Step 6

Remove the mounting hardware that supports the motor frame using a 7/16" ratchet and a 7/16" wrench and remove the ECM or VFD motor. Hardware is shown in Figure 8-1 and must be saved.

Step 7

Install the replacement motor by following Steps 1 through 6 in reverse order.

9: Accessories

This section details the available field-installable accessories and approved modifications for your Spectrum Blower.

Mounting Stand

Mounting support is recommended prior to the installation of the Spectrum Blower. Made from painted steel, Labconco sells mounting stands in a 12" and 18" size.

Catalog Number	Description
7174600	12" Mini Split Stand
7174700	18" Mini Split Stand

Vibration Isolator Kit, (#7174900)

In addition to the curb, vibration isolators or vibration mounting pads improve the support for blowers. Labconco sells an isolator kit compatible with the Mounting Stand (catalog number 7174900).

Thermoplastic Duct

PVC exhaust duct is Type 1, unplasticized, schedule 40, lightweight and corrosion resistant. A female duct coupling is required to join two sections. Connections are simple with solvent cement. This rigid duct comes in 10 foot lengths and can be cut without special tools.

Nominal Diameter/Inches	6	8	10	12	16
Catalog Number	4708600	4718900	7027200	5602000	5605000
Actual OD, Inches	6.63	8.63	10.75	12.75	16.00
Actual ID, Inches	6.25	8.25	10.38	12.38	15.63
Shipping Wt., lbs.	25	35	50	65	80

Duct Couplings, Female

PVC coupling makes connection between two sections of thermoplastic duct quick and easy.

Nominal Diameter/Inches	6	8	10	12	16
Catalog Number	4708900	4719200	7027500	5602300	5605300
Shipping Wt., lbs.	4	5	5	6	7
Equivalent Resistant in Feet of Straight Duct	0	0	0	0	0

Duct Couplings, Male

PVC duct in 6" length facilitates connections between Coated Steel Blowers and elbows, thermoplastic duct reducers and weather caps.

Nominal Diameter/Inches	6	8	10	12
Catalog Number	2144700	4719900	7027800	7027800
Actual OD, Inches	6.63	8.63	10.75	12.75
Actual ID, Inches	6.25	8.25	10.38	12.38
Shipping Wt., lbs.	3	4	5	6

Elbows

PVC elbows both 45° and 90°, are compatible with thermoplastic duct. For quick installation and minimum pressure losses, they feature belled end connections to receive PVC duct directly.

90° Elbow	Nominal Diameter/Inches	6	8	10	12	16
	Catalog Number	4708700	4719000	7027300	5602100	5605100
	Approx. Height, Inches	13.63	17.3	20.38	24.2	29.0
	Equivalent Resistance, Feet	12	15	20	25	36

45° Elbow	Nominal Diameter/Inches	6	8	10	12	16
	Catalog Number	4708800	4719100	7027400	5602200	5605200
	Approx. Height, Inches	8.75	10.75	12.50	15.0	17.50
	Equivalent Resistance, Feet	6	7.5	10	12.5	18

Thermoplastic Duct Reducers

PVC coupling type reducers are designed for connecting thermoplastic duct of different diameters. Compare the blower inlet size with the duct size to see if one is necessary.

Nominal Diameter/Inches	6 x 8	8 x 10	10 x 12	12 x 16
Catalog Number	5605900	5606000	5606100	5630700
Shipping Wt., lbs.	2	5	6	8
Equivalent Resistant in Feet of Straight Duct	0	0	0	0

Zero Pressure Weathercaps

The zero pressure weathercap is made of strong, corrosion-resistant PVC. The cap adds little static pressure to the exhaust system and allows for vertical discharge of the effluent air for dispersion away from the building.

Nominal Diameter/Inches	6	8	10	12	16
Catalog Number	4722200	4722300	7095100	5622100	5622200
Height, Inches	36	40	48	56	72
Shipping Wt., lbs.	20	25	30	35	40
Equivalent Resistant in Feet of Straight Duct	5	5	5	5	5

Spiral Tube

This spiral tube simplifies temporary installations. It is corrosion resistant, neoprene-impregnated fiberglass reinforced with steel wire. Includes rigid duct connector and two clamps. Length is ten feet.

Nominal Diameter/Inches	7" for use with 6" fittings	9" for use with 8" fittings	11" for use with 10" fittings	13" for use with 12" fittings
Catalog Number	1965100	4719400	7027700	5622300
Shipping Wt., lbs.	10	15	20	25
Equivalent Resistant in Feet of Straight Duct	Because this ductwork is flexible and may conform to various configurations, it is not possible to know the precise equivalent resistance.			

Manual Duct Dampers

This PVC damper fitting allows easier airflow balance. It may be used with exhaust and auxiliary air ducts, and is usually placed directly above the fume hood, but can be placed anywhere in the duct system.

Nominal Diameter/Inches	6	8	10	12	16
Catalog Number	4724200	4741300	5983400	5981200	4726400
Shipping Wt., lbs.	10	12	15	20	25
Approx. Height, Inches	14	19.12	19.50	19.67	24

Flexible Duct Connections

This flexible connection reduces vibration between the blower and PVC ductwork. It is supplied with two clamps for easy installation.

Nominal Diameter/Inches	9" for use with 8" fittings	11" for use with 10" fittings	13" for use with 12" fittings
Catalog Number	4726500	7034200	5621400
Shipping Wt., lbs.	5	5	5

Blower Transition Adaptors

This epoxy-coated steel transition adaptor fits all Labconco Coated Steel Blowers. This adaptor allows you to connect round thermoplastic duct to the exhaust side of the blower to create an exhaust stack. Nominal size PVC duct fits inside the adaptor opening.

Nominal Diameter/Inches	8	10	12
Catalog Number	4722400	4722401	7003400
Shipping Wt., lbs.	3	4	4
For use with Labconco Blowers	10" Coated steel		12" Coated steel

T and Y Connections

PVC fittings shaped in T and Y configurations are compatible with thermoplastic duct. End connections receive PVC pipe directly. Contact Labconco for help in sizing blowers with these accessories.

T	Nominal Diameter/Inches	10 x 10 x 12	12 x 12 x 12
	Catalog Number	5630400	5630401
	Shipping Wt., lbs.	20	20
	Approx. Height, Inches	19	17.5

Y	Nominal Diameter/Inches	10 x 10 x 12	12 x 12 x 12	12 x 12 x 16
	Catalog Number	5630100	5630101	5630500
	Shipping Wt., lbs.	19	20	20
	Approx. Height, Inches	12.75	18.7	23.75

Backdraft Dampers

Designed for use in buildings under negative pressure to keep outside air from entering the laboratory through the hood ventilation system. Damper is weighted to stay in down/resting position when the hood is not in use and rises from the airflow exhausting when the blower is on. It mounts vertically on blower outlet. The damper is made of PVC Type 1, unplasticized, schedule 40 duct.

Nominal Diameter/Inches	8	10	12
Catalog Number	S304508	S304510	S304512
Shipping Wt., lbs.	15	18	20

Accessory for perchloric Acid Applications

Wash Rings

Wash rings are suited for use in Perchloric acid duct systems. Each features a wide-angle conical spray nozzle and wash water connector nipple fabricated into a PVC coupling for use with 10" or 12" nominal duct.

Nominal Diameter/Inches	10	12
Catalog Number	4746000	4746100
Shipping Wt., lbs.	5	6

10: Troubleshooting

This section details common troubleshooting for your Spectrum Blower.

Contamination Outside Fume Hood

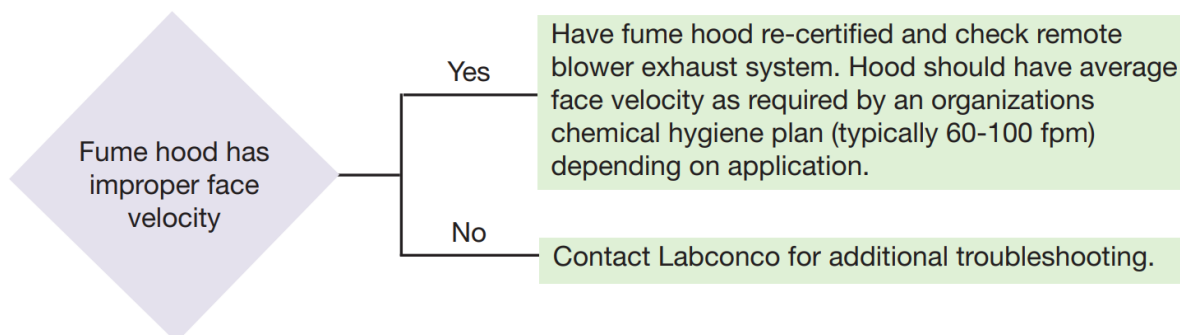

Control Panel Display Not Functioning, Blower OK

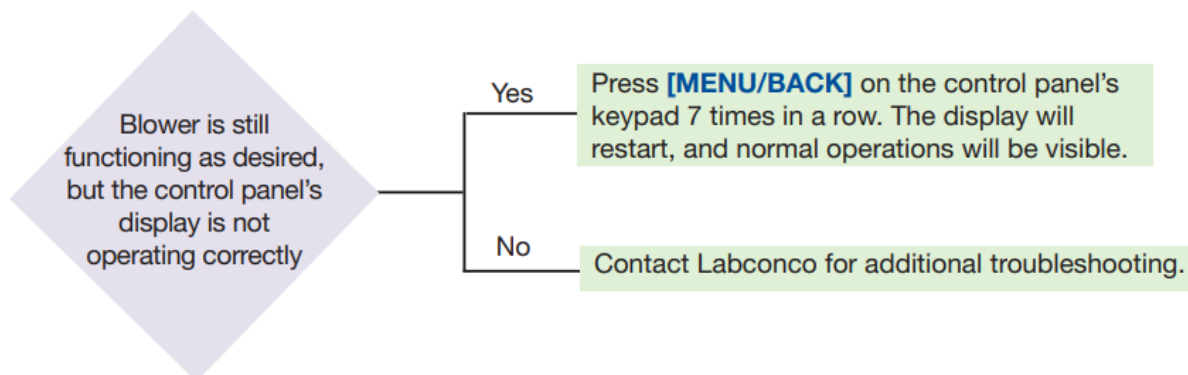

Blower Not Working, Error Code 'B'

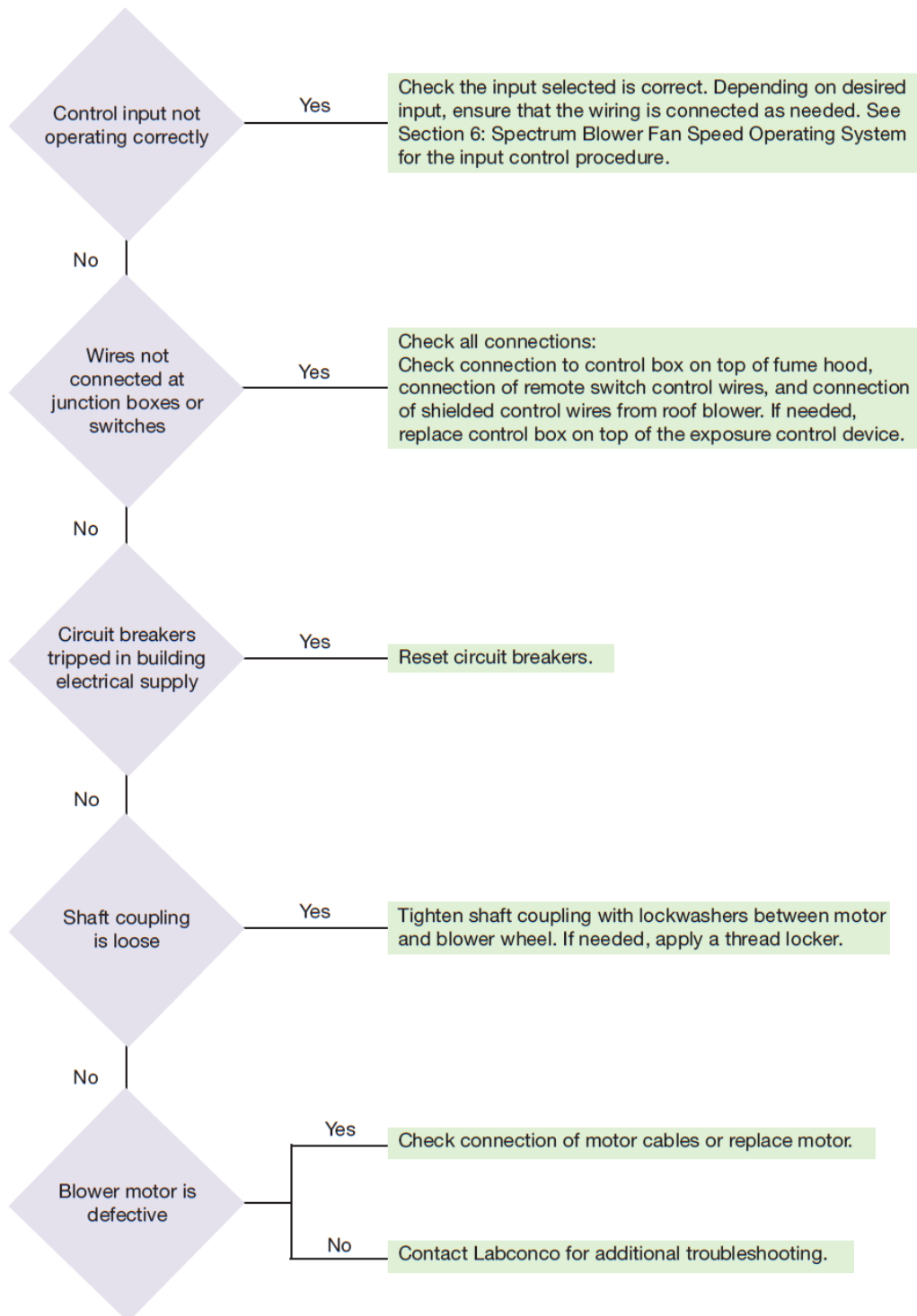

To clear the 'B' alarm when using BMS signal WITHOUT a remote ON/OFF switch, the signal must be dropped beneath 1V or 4mA.

Blower Has Excessive Vibration

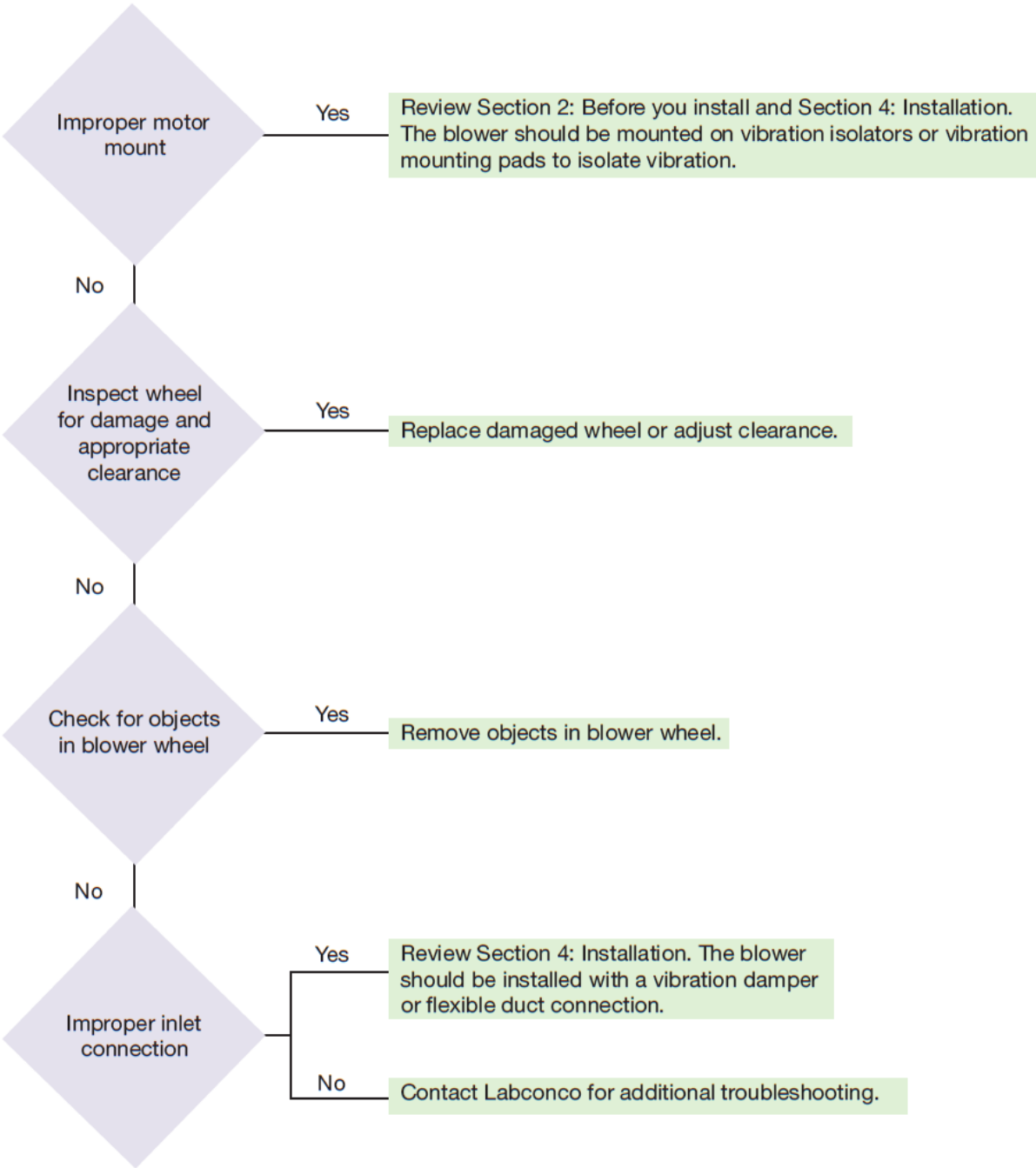

Fume Hood Has Improper Face Velocity

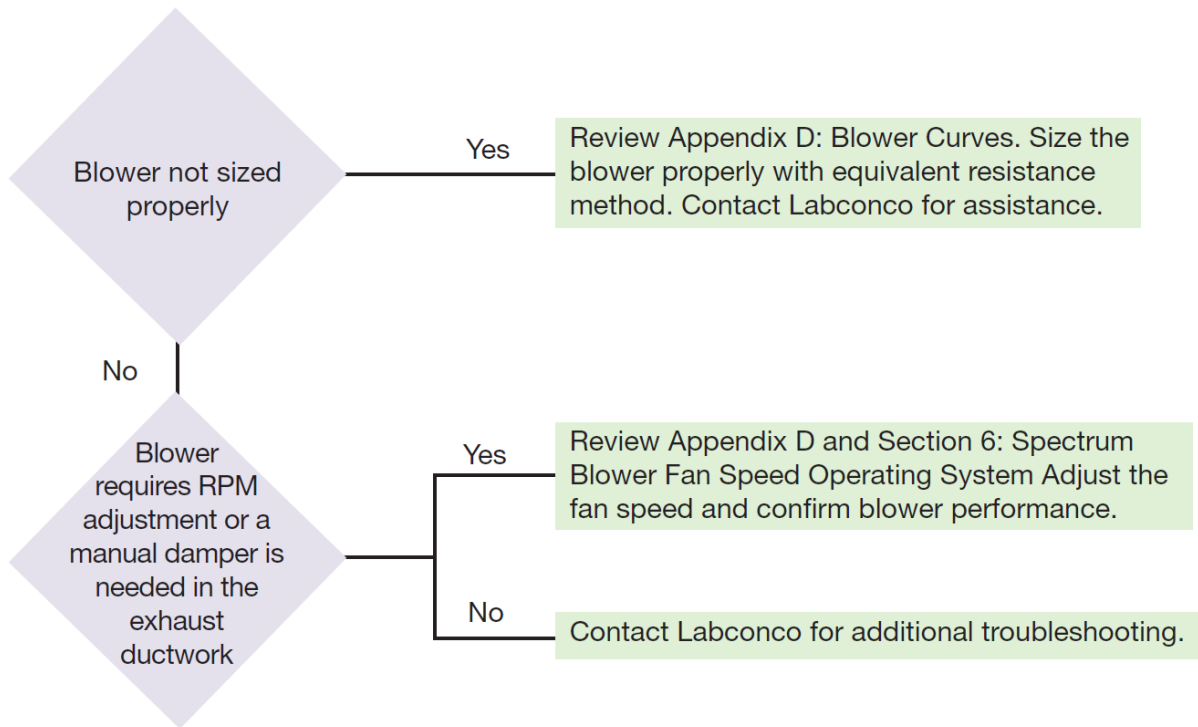

Overcurrent, Error Code 'C'

Use fume hood with extra attention being paid to the airflow sensor readings to ensure safety.

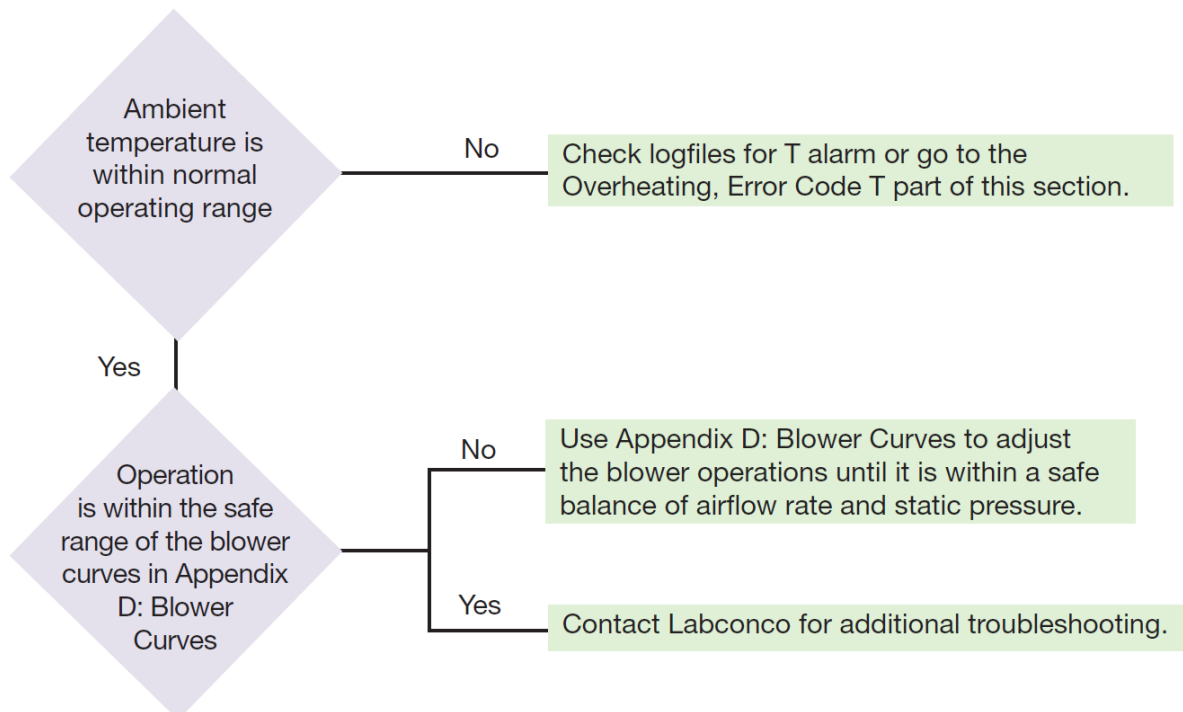

Overheating, Error Code 'T'

Use fume hood with extra attention being paid to the airflow sensor readings to ensure safety.

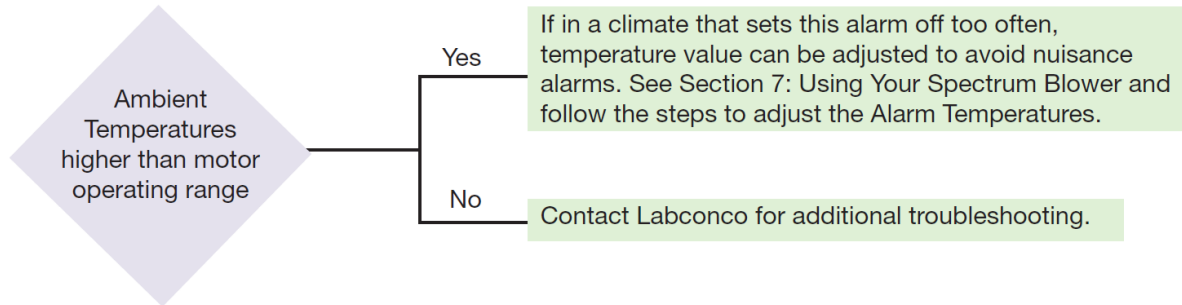

Too Cold for Motor to start, Error Code 'T'

If unsuccessfully attempting to start the motor in a temperature outside the lower operating range detailed in [Appendix C: Environmental Conditions](#), the 'T' alarm will be present, followed by the 'B' alarm. Follow the instructions below to cold start the motor:

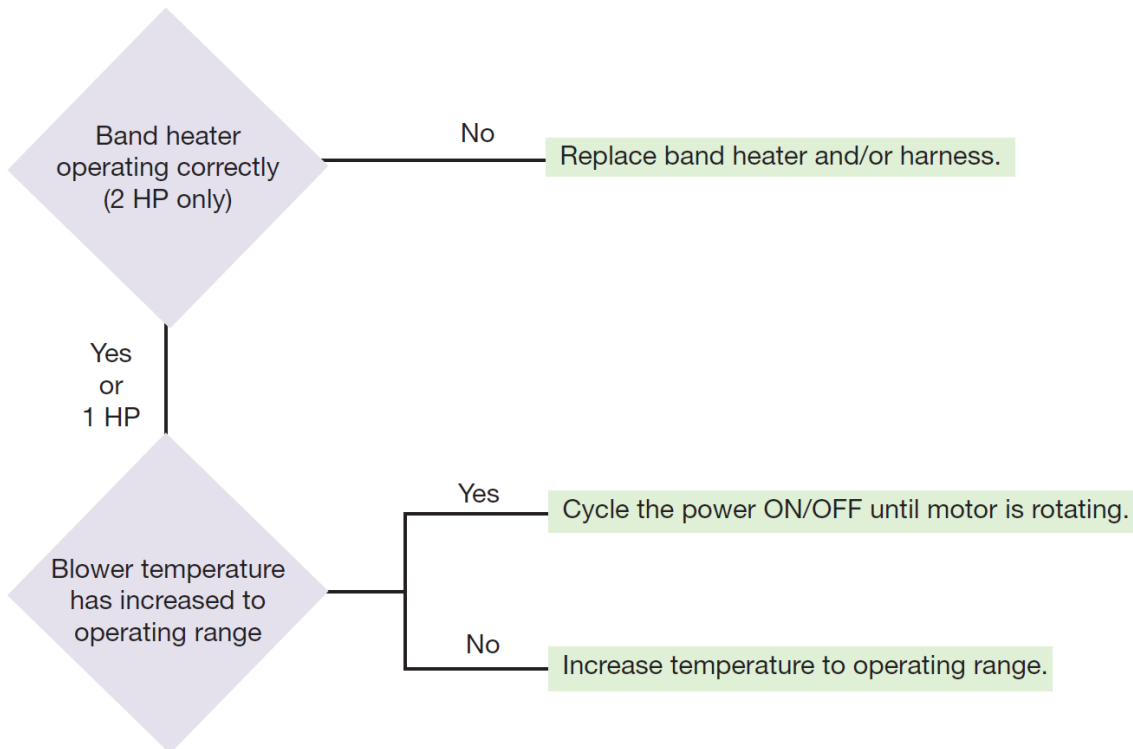

If experiencing or expecting temperatures below the lower operating limits of the motor (see [Appendix C: Environmental Conditions](#) for operating range), run the blower at a low RPM instead of shutting off completely.

Appendix A: Parts List

Table A-1 and Figure A-1 indicate the location and catalog numbers for the following service, and replacement accessory components for the 1 HP ECM Spectrum Blowers.

Table A-1

Item	Quantity Required	Catalog Number	Description
1	1	7117101	Shaft Coupler, 1/2 x 5/8
	4	1889012	Coupler, Socket Head Screw 10-32 x .75"
	4	1910110	Coupler, Lockwasher #10
	1	7116100	Fan, Motor Cooling
2	1	7116201	ECM Motor, 1 HP - 10" Coated Steel, 1900 RPM
	1	7116202	ECM Motor, 1 HP - 12" Coated Steel, 1250 RPM
	1	7116203	ECM Motor, 1 HP - 10" Fiberglass, 1900 RPM
	1	7116204	ECM Motor, 1 HP - 12" Fiberglass, 1500 RPM
	1	7116205	ECM Motor, 1 HP - 10" PVC, 1900 RPM
	1	7116206	ECM Motor, 1 HP - 12" PVC, 1500 RPM
	1	3843500	Motor Clamp Bracket
	3	7117000	Vibration Foot Support, Motor
	1	1880924	Screw, Motor Clamp
	1	1905623	Nut, Motor Clamp
	3	1881020	Screw, Vibration Mount
	3	1906921	Nut, Vibration Mount
3	1	7117800	Impeller Wheel Assembly, 10" Coated Steel
	1	7117801	Impeller Wheel Assembly, 12" Coated Steel
	1	7117200	Impeller Wheel Assembly, 10" Fiberglass

Item	Quantity Required	Catalog Number	Description
3	1	7117201	Impeller Wheel Assembly, 12" Fiberglass
	1	7117202	Impeller Wheel Assembly, 10" PVC
	1	7117203	Impeller Wheel Assembly, 12" PVC
4	1	7099100	Shaft Seal
	1	1852400	Key, Shaft
5	1	7116700	Internal rain guard, Motor Cover
	1	7171000	Weather Cover
	6	1885806	Screw, Weather Cover
6	1	1860500	Flanged Pillow Block Bearing 5/8" Bore
	2	1881712	Screw – Cap Hex Head 3/8 – 16 x 0.75" SS
	2	1910018	Lockwasher 3/8
7	1	9610000	Product Control Board
8	1	7172500	Harness, Control Board Power
	1	7173800	Harness, 1 HP, AC Branch
	1	7173900	Harness, 1 HP, DC Branch
	1	7174400	Harness, Relay Control
	1	7174500	Harness, Relay Digital
9	1	7171500	J-Box, Cover, AC Select Assembly
10	1	4591300	Temp probe, 3/8-24 threaded end

Figure A-1

1 HP Spectrum Blower

2 HP Spectrum Blower

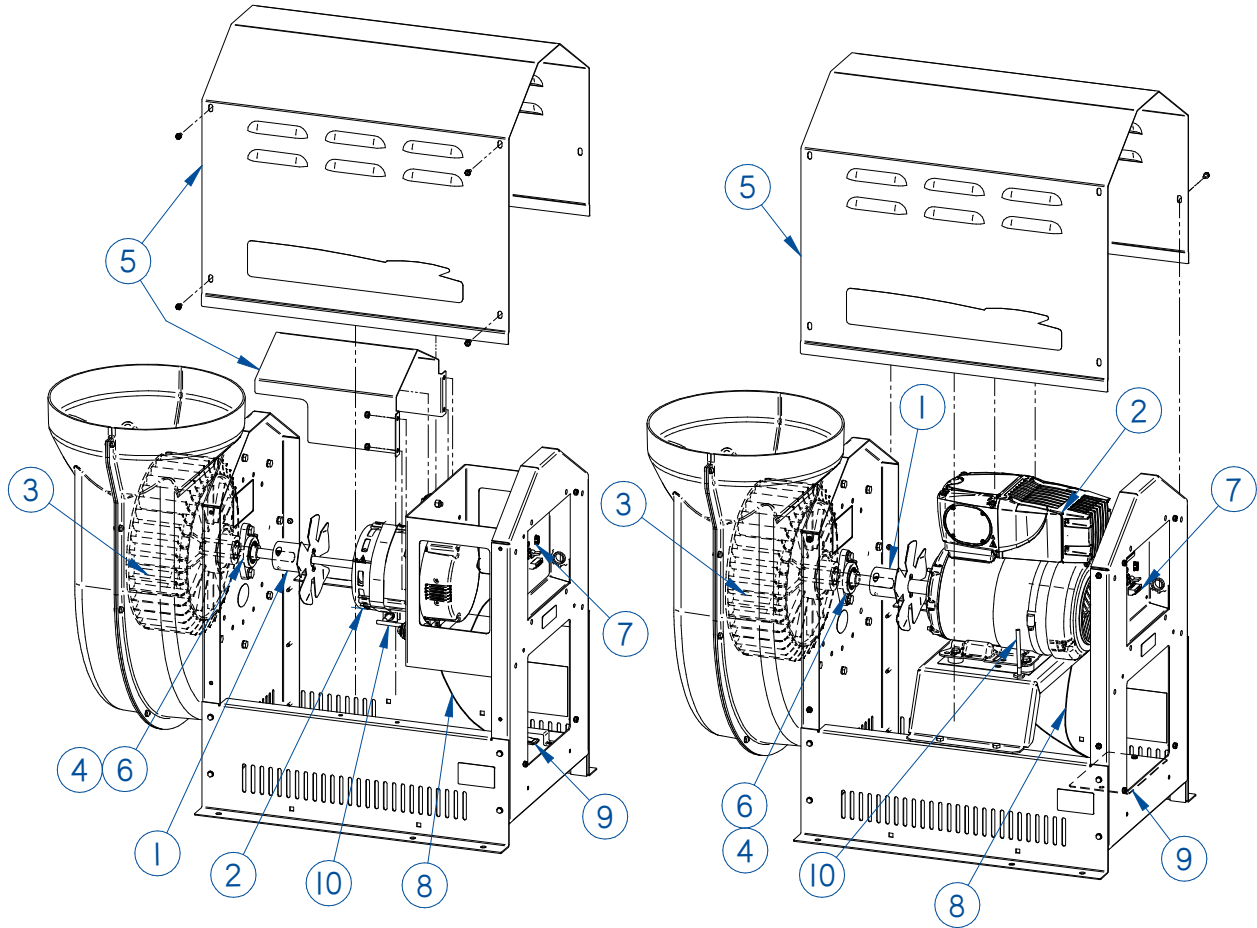

Table A-2 and Figure A-1 indicate the location and catalog numbers for the following service, and replacement accessory components for the 2 HP VFD Spectrum Blowers.

Table A-2

Item	Quantity Required	Catalog Number	Description
1	1	7117102	Shaft Coupler, 7/8 x 5/8
	4	1889012	Coupler, Socket Head Screw 10-32 x .75"
	4	1910110	Coupler, Lockwasher #10
	1	7116100	Fan, Motor Cooling
2	1	7171401	VFD Motor, 2 HP - 12" Coated Steel, 2000 RPM
	1	7171402	VFD Motor, 2 HP - 12" Fiberglass, 2250 RPM
	1	7171403	VFD Motor, 2 HP - 12" PVC, 2250 RPM
	1	1968500	Motor Clamp Bracket
	1	7172300	Band Heater, Motor
	1	7172600	Shim plate, Vibration Motor
	4	7172700	Vibration Foot Support, Motor
	4	1881005	Screw, Vibration Mount
	4	1906921	Nut, Vibration Mount
3	1	7117801	Impeller Wheel Assembly, 12" Coated Steel
	1	7117201	Impeller Wheel Assembly, 12" Fiberglass
	1	7117203	Impeller Wheel Assembly, 12" PVC
4	1	7099100	Shaft Seal
	1	1852400	Key, Shaft
5	1	7116700	Internal rain guard, Motor Cover
	1	7171000	Weather Cover
	6	1885806	Screw, Weather Cover

Item	Quantity Required	Catalog Number	Description
6	1	1860500	Flanged Pillow Block Bearing 5/8" Bore
	2	1881712	Screw – Cap Hex Head 3/8 – 16 x 0.75" SS
	2	1910018	Lockwasher 3/8
7	1	9610000	Product Control Board
8	1	7172500	Harness, Control Board Power
	1	7174000	Harness, 2 HP, AC Branch
	1	7174100	Harness, 2 HP, DC Branch
	1	7174400	Harness, Relay Control
	1	7174500	Harness, Relay Digital
9	1	9816800	J-Box, Cover
10	1	4591300	Temp probe, 3/8-24 threaded end

Appendix B: Dimensions

Table B-(1, 2, & 3) and Figure B-(1, 2, & 3) indicate the product dimensions. All dimensions shown in inches.

Coated Steel Blowers

Table B-1

Nominal Inlet	A	B	C	D	E	Inlet	Outlet Width	Outlet Depth
10"	7.2" (18.2cm)	7.0" (17.8cm)	8.1" (20.7cm)	6.8" (17.3cm)	9.25" (23.5cm)	10.9" ID (27.6cm)	10.0" (25.4cm)	5.5" (14.0cm)
12"	8.6" (21.7cm)	9.0" (22.9cm)	10.5" (26.7cm)	9.0" (22.9cm)	12.5" (31.8cm)	12.25" OD (31.1cm)	13.5" (34.3cm)	7.0" (17.8cm)

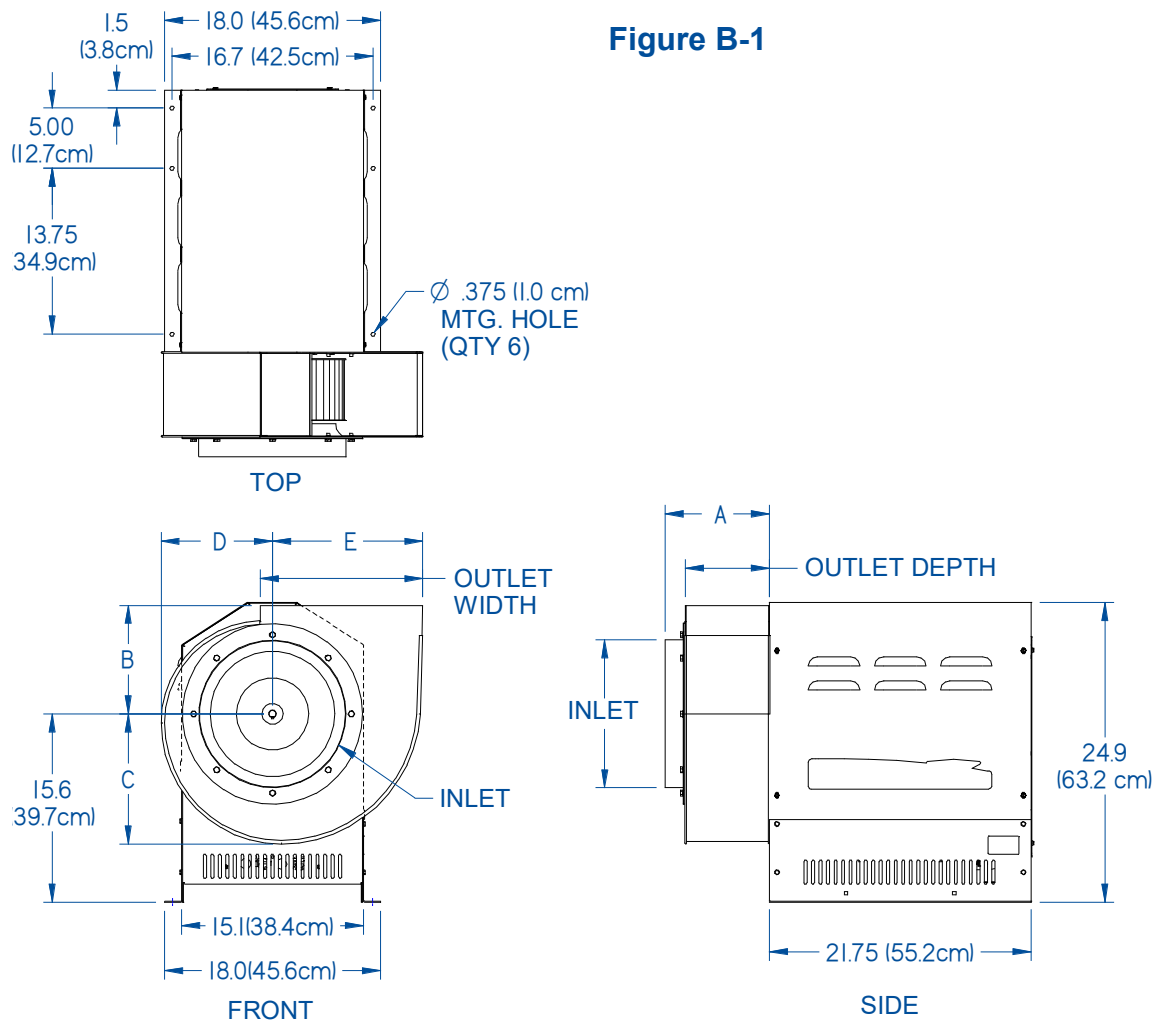

Fiberglass Blowers

Table B-2

Nominal Inlet	A	B	C	D	F	E	Inlet (OD)	Outlet (ID)
10"	7.1" (18.1cm)	12.7" (32.2cm)	10.5" (26.7cm)	8.75" (22.2cm)	7.5" (19.1cm)	13.9" (35.3cm)	10.4" (26.4cm)	10.75" (26.4cm)
12"	8.0" (20.3cm)	13.2" (33.5cm)	12.0" (30.5cm)	10.0" (25.4cm)	8.5" (21.6cm)	15.9" (40.3cm)	12.4" (108.2cm)	12.75" (32.4cm)

Figure B-2

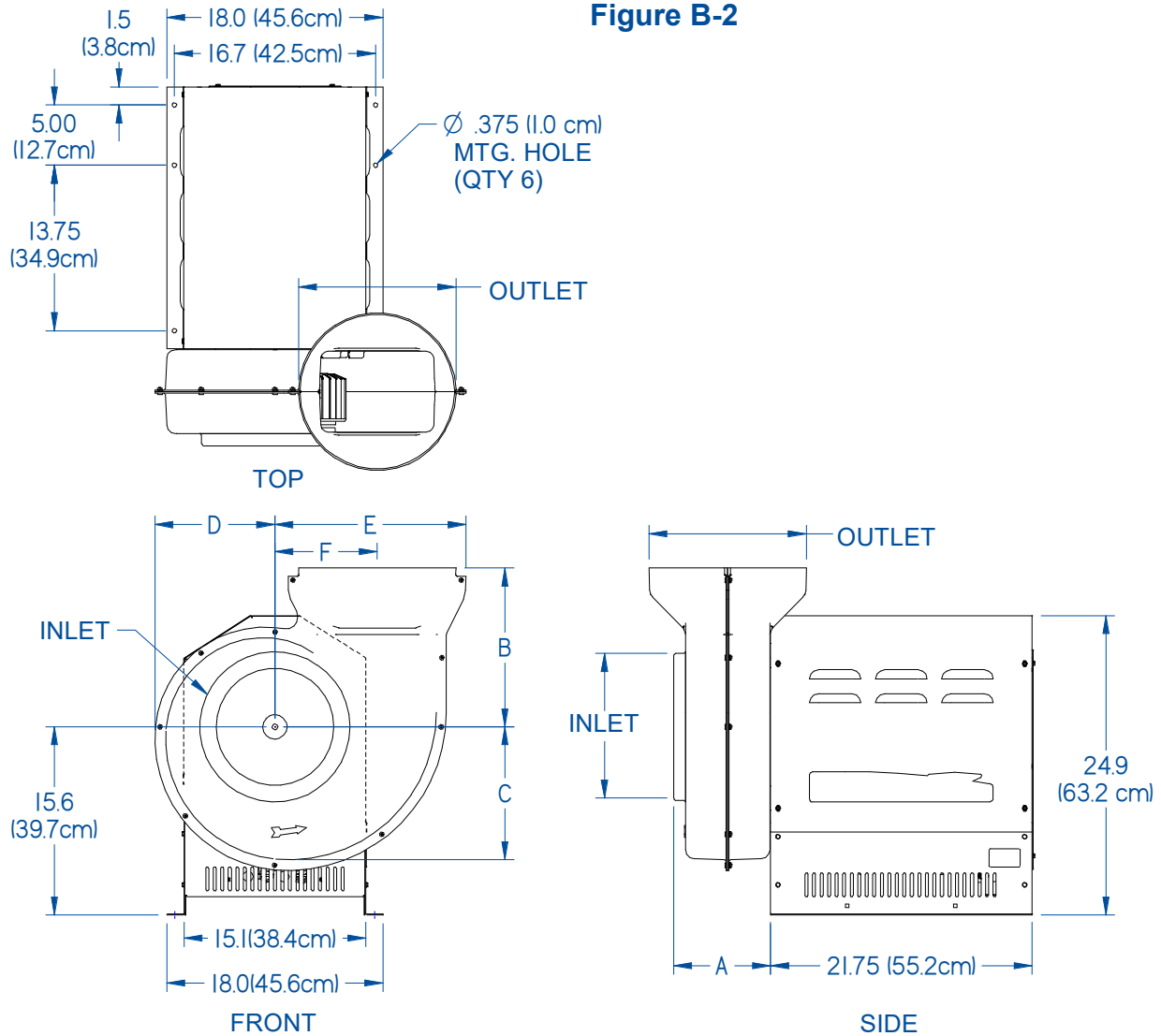

PVC Blowers

Table B-3

Nominal Inlet	A	B	C	D	F	E	Inlet (OD)	Outlet (ID)
10"	7.1" (18.1cm)	12.7" (32.2cm)	10.5" (26.7cm)	8.75" (22.2cm)	7.5" (19.1cm)	13.9" (35.3cm)	10.4" (26.4cm)	10.75" (26.4cm)
12"	8.0" (20.3cm)	13.2" (33.5cm)	12.0" (30.5cm)	10.0" (25.4cm)	8.5" (21.6cm)	15.9" (40.3cm)	12.4" (108.2cm)	12.75" (32.4cm)

Figure B-3

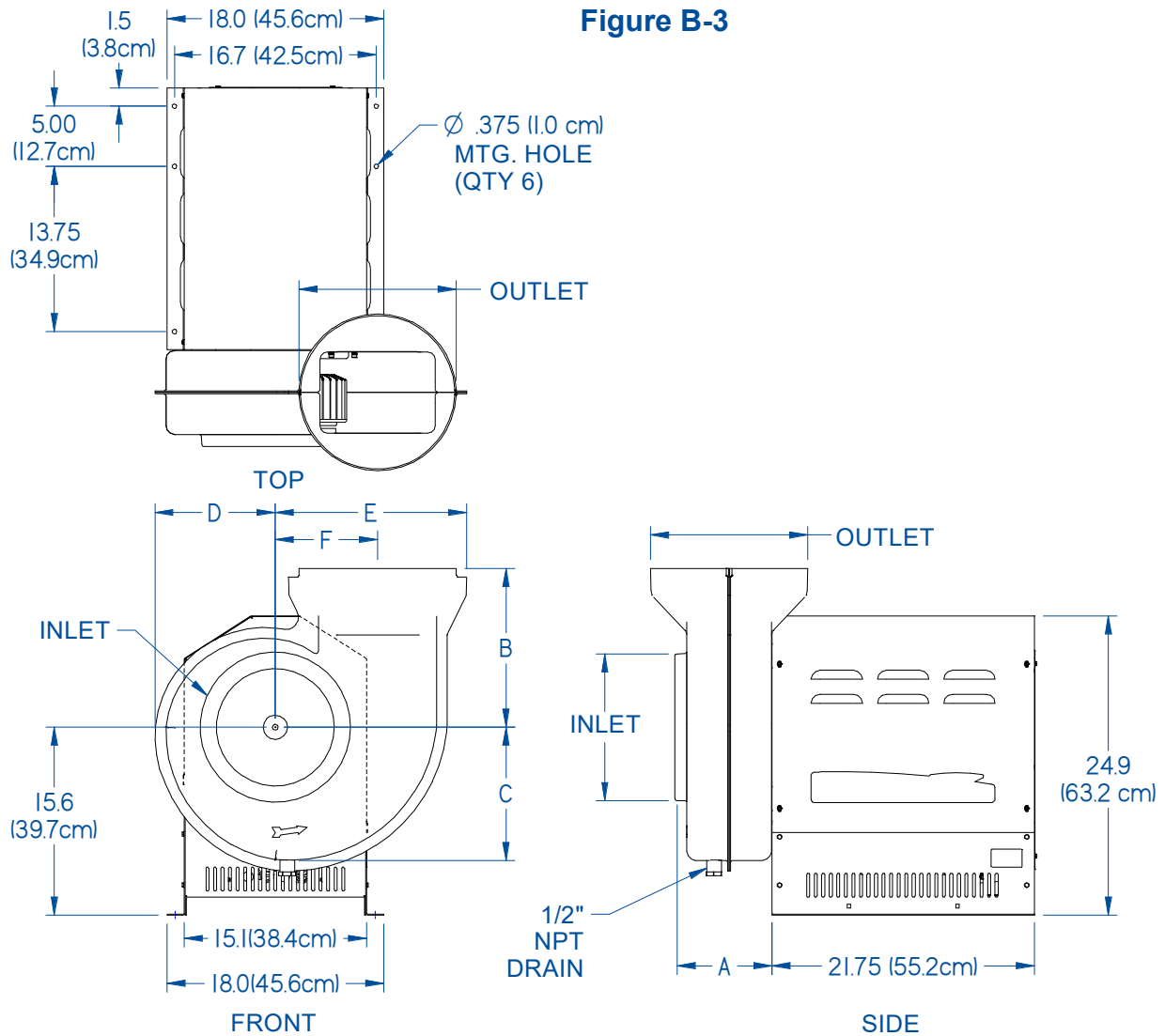

Appendix C: Specifications

Wiring Diagrams

The wiring diagrams and harness are slightly different based on the motor in the Spectrum Blower. Figure C-1 shows the 1 HP ECM wiring diagram. Figure C-2 shows the 2 HP VFD wiring diagram. The blower size or voltage rating does not affect the wiring diagram to reference.

1 HP:

Figure C-1

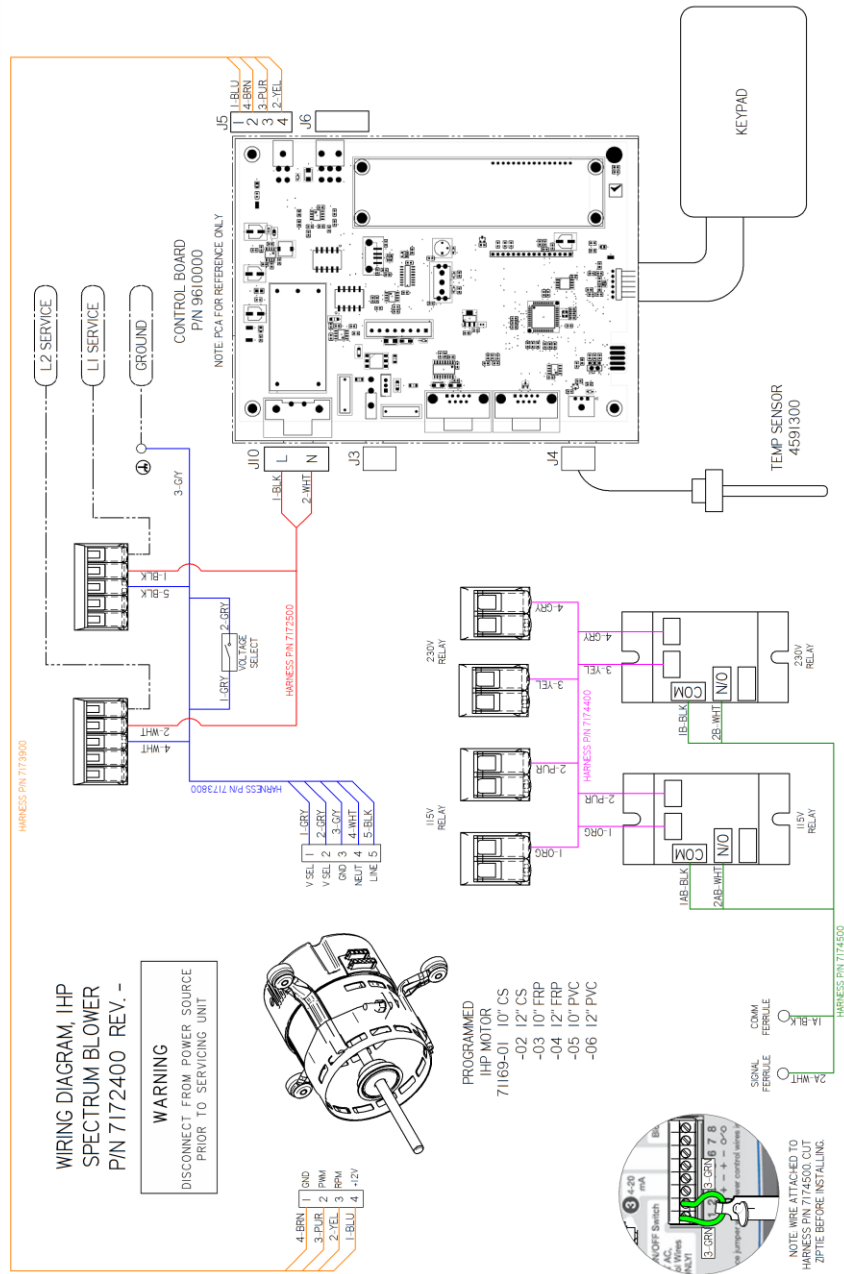

Motor Specifications

Table C-1

Product Size	Electrical Requirements
1 HP, all Voltages	1 H.P. Electronically Commutated Motor (ECM) 120-240 VAC – 50/60 Hz, Single Phase Only Full Torque – 80.0 Oz.-Ft (6.78 N-M) 11.6 Full Load Amps @115VAC 7.3-6.8 Full Load Amps @230VAC Automatic Thermal Protection

Product Size	Electrical Requirements
2 HP, 230 V	2 H.P. Variable Frequency Drive 208-230 VAC – 50/60 Hz, Single or 3-Phase Full Torque – 96.0 Oz.-ft (8.13 N-M) 8.5 Full Load Amps @230VAC Automatic Thermal Protection

Environmental Conditions

- Maximum altitude: 9843 feet (3000 meters).
- Ambient temperature range:
 - 1 HP: -30° to 130°F (-34° to 54°C).
 - 2 HP: 3° to 122°F (-16° to 50°C).
- Main supply voltage fluctuations not to exceed $\pm 10\%$ of the nominal voltage.
- Transient over-voltages according to Installation Categories II (Overvoltage Categories per IEC 1010). Temporary voltage spikes on the AC input line that may be as high as 1500V for 115V models and 2500V for 230V models are allowed.
- Used in an environment of Pollution degrees 2 (i.e., where normally only non-conductive atmospheres are present). Occasionally, however, a temporary conductivity caused by condensation must be expected, in accordance with IEC 664.

Appendix D: Blower Curves

If using the Spectrum Blower for a benchtop fume hood:

1 HP ECM Spectrum Blower Quick Selection Guide									
Hood Size	3'	4'	5'	6'	7'	8'	10'	12'	16'
10" Blower Airflow Range (CFM)	175-495	175-735	175-955	175-1100	175-1100	175-1100	N/A	N/A	N/A

Note: 10" Blowers have a minimum achievable airflow of 175CFM and a maximum airflow of 1100CFM

12" Blower Airflow Range (CFM)	200-495	200-735	200-955	200-1180	200-1410	200-1410	200-1410	200-1410	200-1410
--------------------------------	---------	---------	---------	----------	----------	----------	----------	----------	----------

Note: 12" Blowers have a minimum achievable airflow of 200CFM and a maximum airflow of 1410CFM

18" Reduced Sash Height	10" Blower	10" Blower	10" Blower	10" or 12" Blower	10" or 12" Blower	10" or 12" Blower	12" Blower	12" Blower	12" Blower
28" Full Open Sash Height	10" or 12" Blower	10" or 12" Blower	10" or 12" Blower	12" Blower	12" Blower	12" Blower	12" Blower	N/A	N/A
Sash Height and Airflow Restrictions (if any)	None	None	None	None	None	None	80fpm max. at full open 28" sash	60fpm max. at full open 28" sash	80fpm max. at 60% open 18" sash 60fpm max. at 60% open 18" sash

Note: For best results, always use a manual damper in the exhaust for fine tuning blower along with variable speed RPM motor.

2 HP VFD Spectrum Blower Quick Selection Guide									
Hood Size	3'	4'	5'	6'	7'	8'	10'	12'	16'
12" Blower Airflow Range (CFM)	175-495	175-725	175-955	175-1180	175-1410	175-1640	180-2100	222-2560	300-2800
Sash Height and Airflow Restrictions (if any)	None	None	None	None	None	None	None	None	80fpm max. at full open 28" sash

Corrosion Resistance Guide	
Mild to moderate corrosive chemicals	Coated Steel Blowers
Moderate to highly corrosive chemicals	Fiberglass FRP Blowers
Highly corrosive acids	PVC Blowers

10" Coated Steel, 1 HP ECM

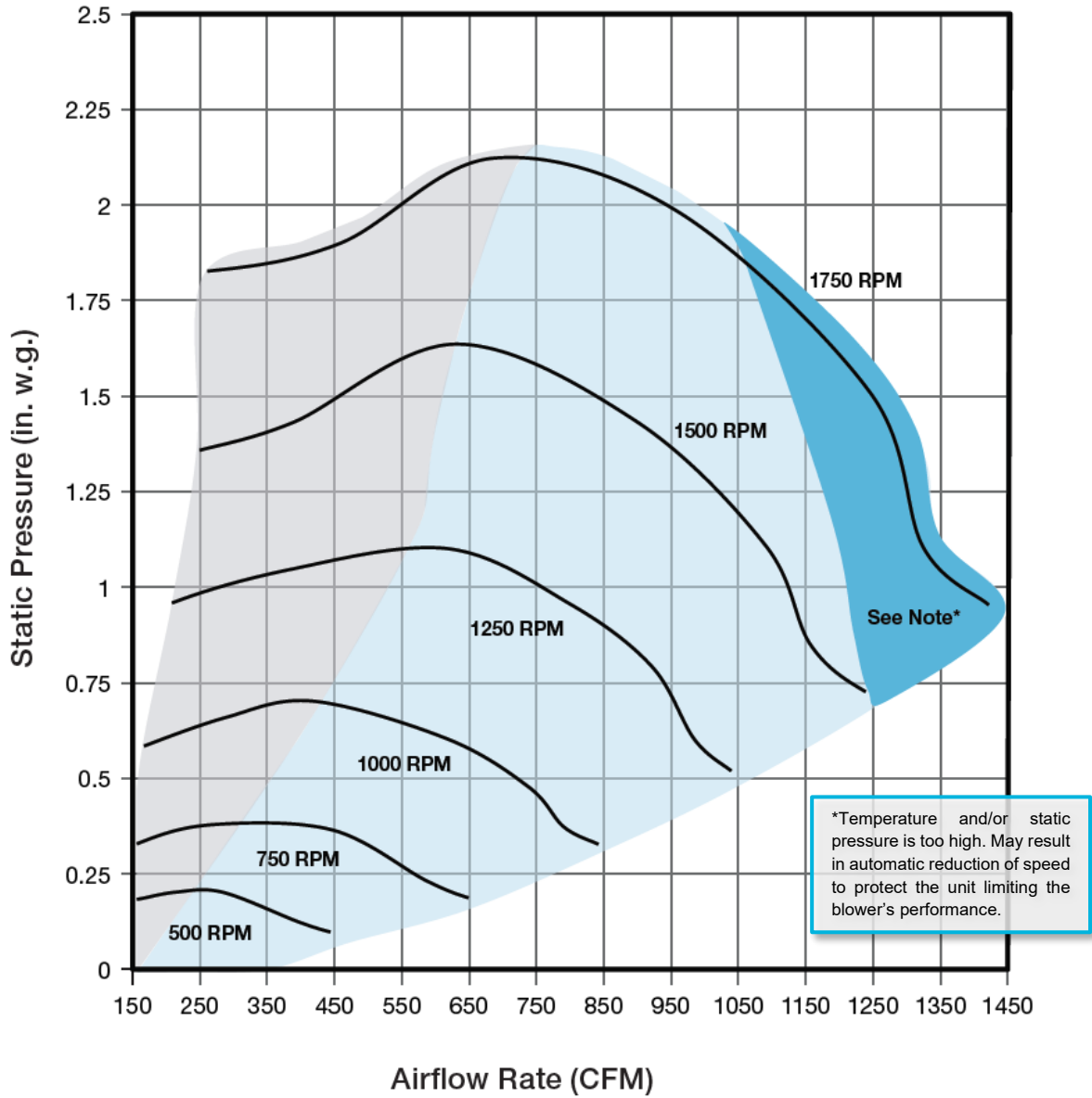

Speed (RPM)	Optimum Airflow (CFM) and Static Pressure (inches of water)	0-10 vdc Signal	4-20mA Signal
1900 MAX	750 CFM @ 2.2" to 1000 CFM @ 2.0"	9.0	19.9
1750	700 CFM @ 2.2" to 1050 CFM @ 1.8"	8.2	18.5
1500	650 CFM @ 1.6" to 1250 CFM @ 0.7"	7.1	16.2
1250	550 CFM @ 1.1" to 1050 CFM @ 0.5"	6.0	13.9
1000	400 CFM @ 0.7" to 850 CFM @ 0.33"	4.9	11.7
750	275 CFM @ 0.37" to 650 CFM @ 0.20"	3.7	9.4
500	200 CFM @ 0.20" to 450 CFM @ 0.10"	2.6	7.1
300	175 CFM @ 0.06" to 350 CFM @ 0.08"	1.7	5.3

10" Fiberglass, 1 HP ECM

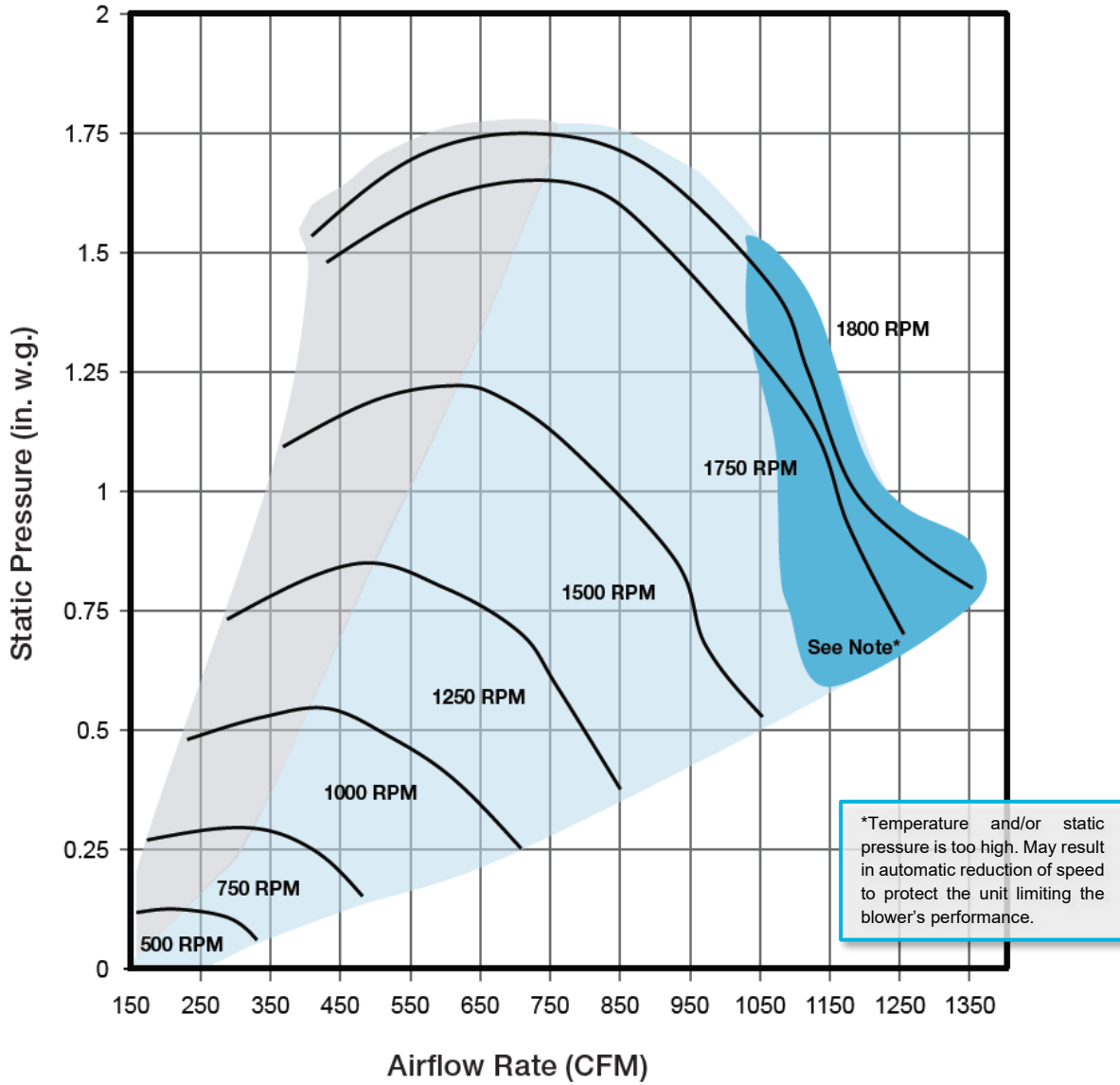

Speed (RPM)	Optimum Airflow (CFM) and Static Pressure (inches of water)	0-10 vdc Signal	4-20mA Signal
1900 MAX	760 CFM @ 1.8" to 1000 CFM @ 1.6"	9.0	19.9
1750	750 CFM @ 1.6" to 1000 CFM @ 1.4"	8.2	18.5
1500	600 CFM @ 1.2" to 1050 CFM @ 0.5"	7.1	16.2
1250	500 CFM @ 0.8" to 850 CFM @ 0.37"	6.0	13.9
1000	400 CFM @ 0.6" to 700 CFM @ 0.25"	4.9	11.7
750	300 CFM @ 0.3" to 475 CFM @ 0.12"	3.7	9.4
500	200 CFM @ 0.12" to 325 CFM @ 0.06"	2.6	7.1
300	175 CFM @ 0.06" to 275 CFM @ 0.04"	1.7	5.3

10" PVC, 1 HP ECM

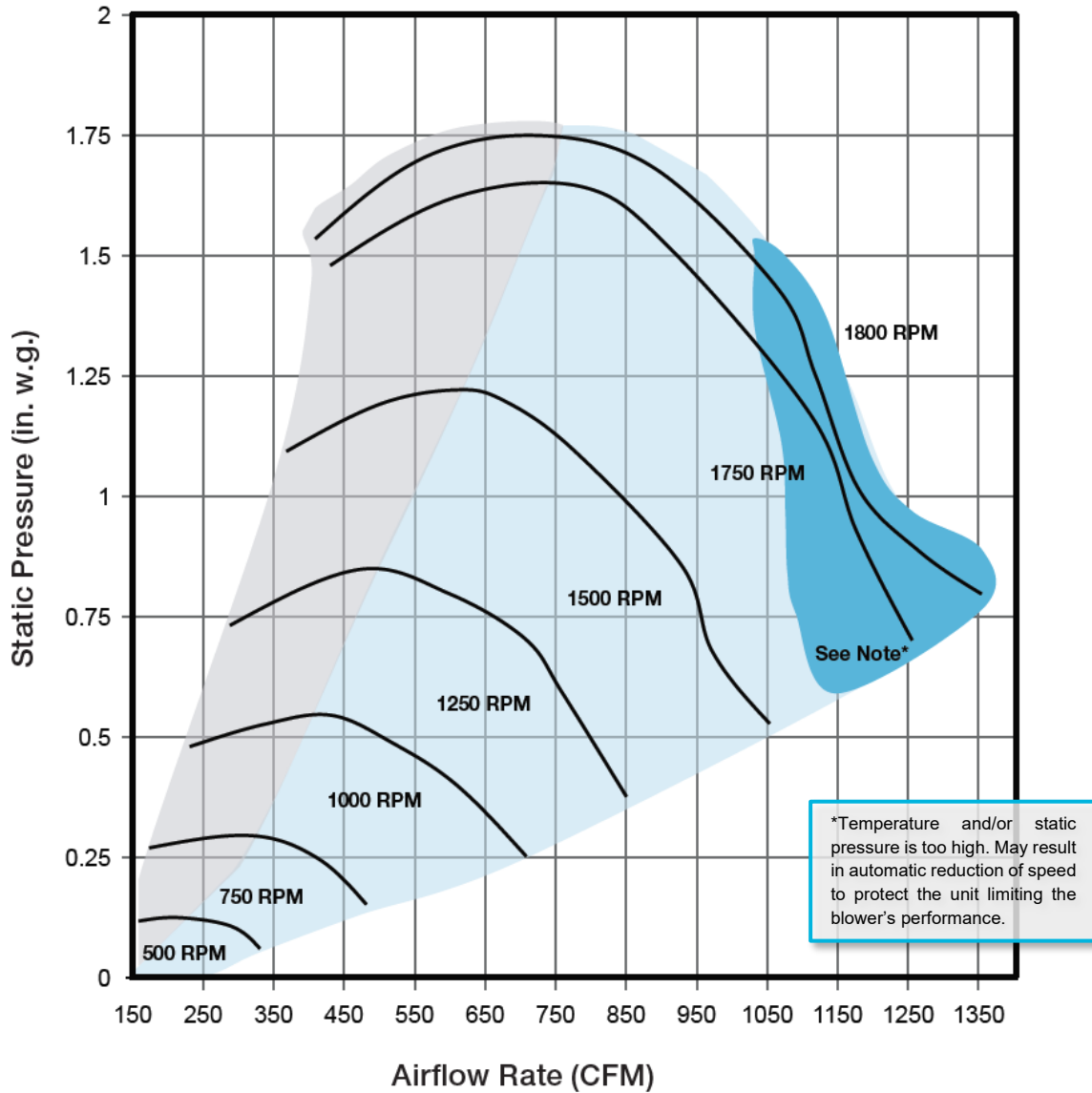

Speed (RPM)	Optimum Airflow (CFM) and Static Pressure (inches of water)	0-10 vdc Signal	4-20mA Signal
1900 MAX	600 CFM @ 1.8" to 1050 CFM @ 1.4"	9.0	19.9
1750	650 CFM @ 1.6" to 1100 CFM @ 1.1"	8.2	18.5
1500	600 CFM @ 1.2" to 1050 CFM @ 0.5"	7.1	16.2
1250	500 CFM @ 0.8" to 850 CFM @ 0.37"	6.0	13.9
1000	400 CFM @ 0.6" to 700 CFM @ 0.25"	4.9	11.7
750	300 CFM @ 0.3" to 475 CFM @ 0.12"	3.7	9.4
500	200 CFM @ 0.12" to 325 CFM @ 0.06"	2.6	7.1
300	175 CFM @ 0.06" to 275 CFM @ 0.04"	1.7	5.3

12" Coated Steel, 1 HP ECM

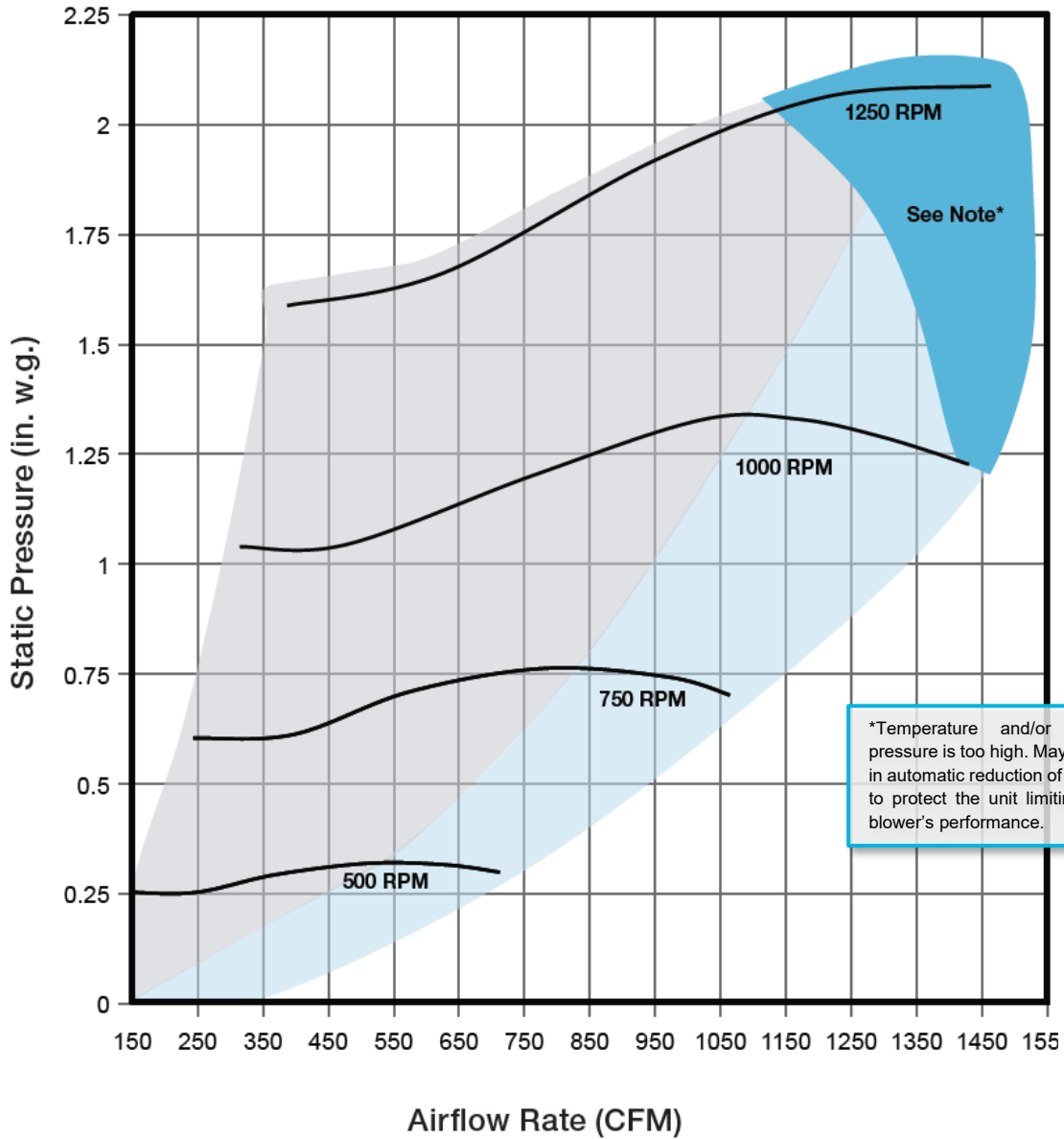

Speed (RPM)	Optimum Airflow (CFM) and Static Pressure (inches of water)	0-10 vdc Signal	4-20mA Signal
1250 MAX	1350 CFM @ 2.1" to 1470 CFM @ 2.1"	9.0	20.0
1000	1100 CFM @ 1.3" to 1450 CFM @ 1.2"	7.1	16.2
750	800 CFM @ 0.8" to 1150 CFM @ 0.7"	5.1	12.4
500	550 CFM @ 0.33" to 725 CFM @ 0.3"	3.3	8.6
300	200 CFM @ 0.08" to 450 CFM @ 0.1"	1.8	5.6

12" Fiberglass, 1 HP ECM

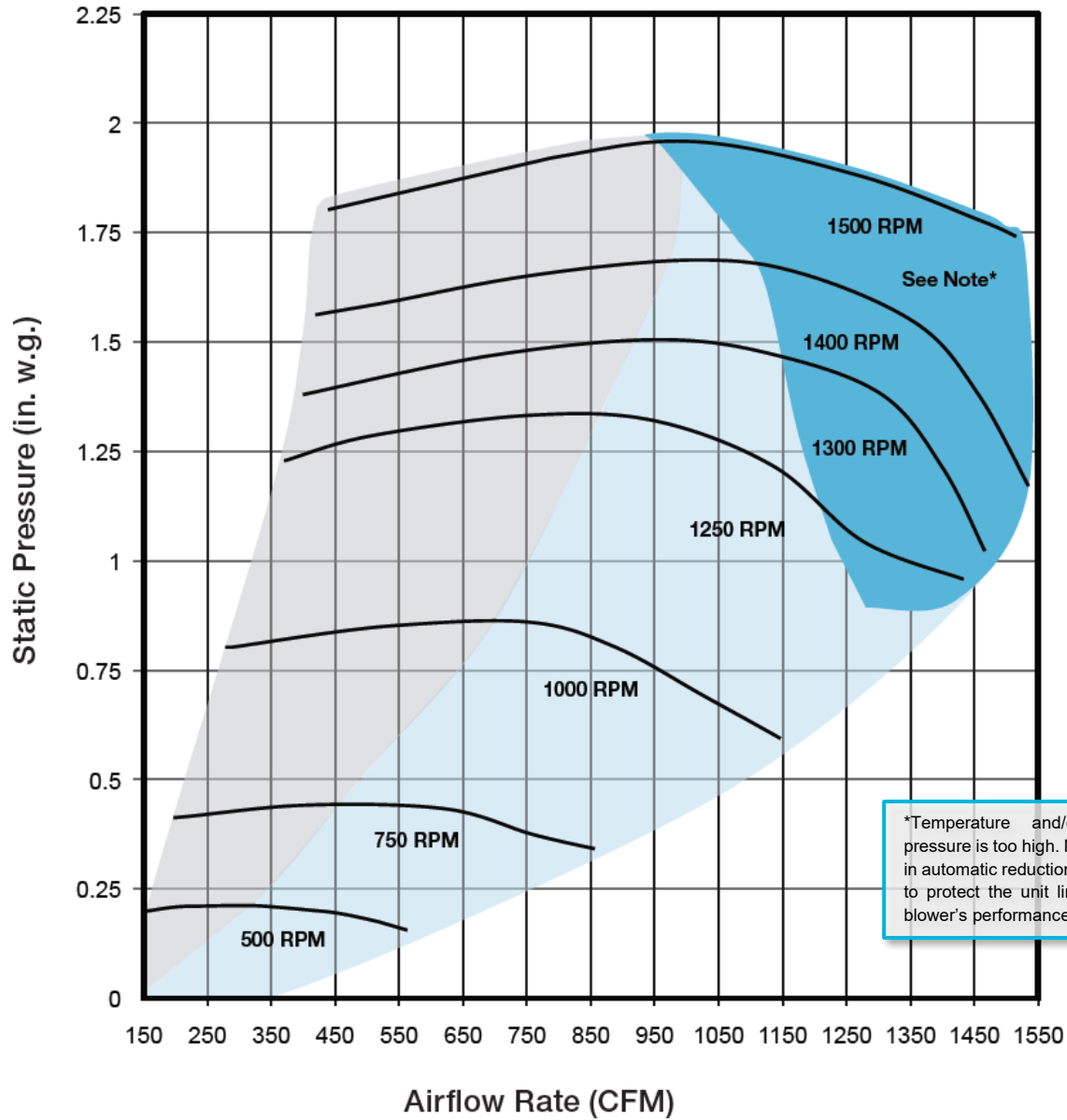

*Temperature and/or static pressure is too high. May result in automatic reduction of speed to protect the unit limiting the blower's performance.

Speed (RPM)	Optimum Airflow (CFM) and Static Pressure (inches of water)	0-10 vdc Signal	4-20mA Signal
1500 MAX	1000 CFM @ 1.8" to 1500 CFM @ 1.7"	9.0	20.0
1300	900 CFM @ 1.5" to 1150 CFM @ 1.4"	7.7	17.6
1250	850 CFM @ 1.3" to 1400 CFM @ 0.87"	7.4	16.9
1125	780 CFM @ 1.1" to 1310 CFM @ 0.75"	6.7	15.4
1000	700 CFM @ 0.87" to 1180 CFM @ 0.62"	6.0	13.9
750	450 CFM @ 0.4" to 860 CFM @ 0.34"	4.4	10.9
500	300 CFM @ 0.20" to 575 CFM @ 0.12"	2.9	7.9
300	200 CFM @ 0.08" to 450 CFM @ 0.10"	1.8	5.5

12" PVC, 1 HP ECM

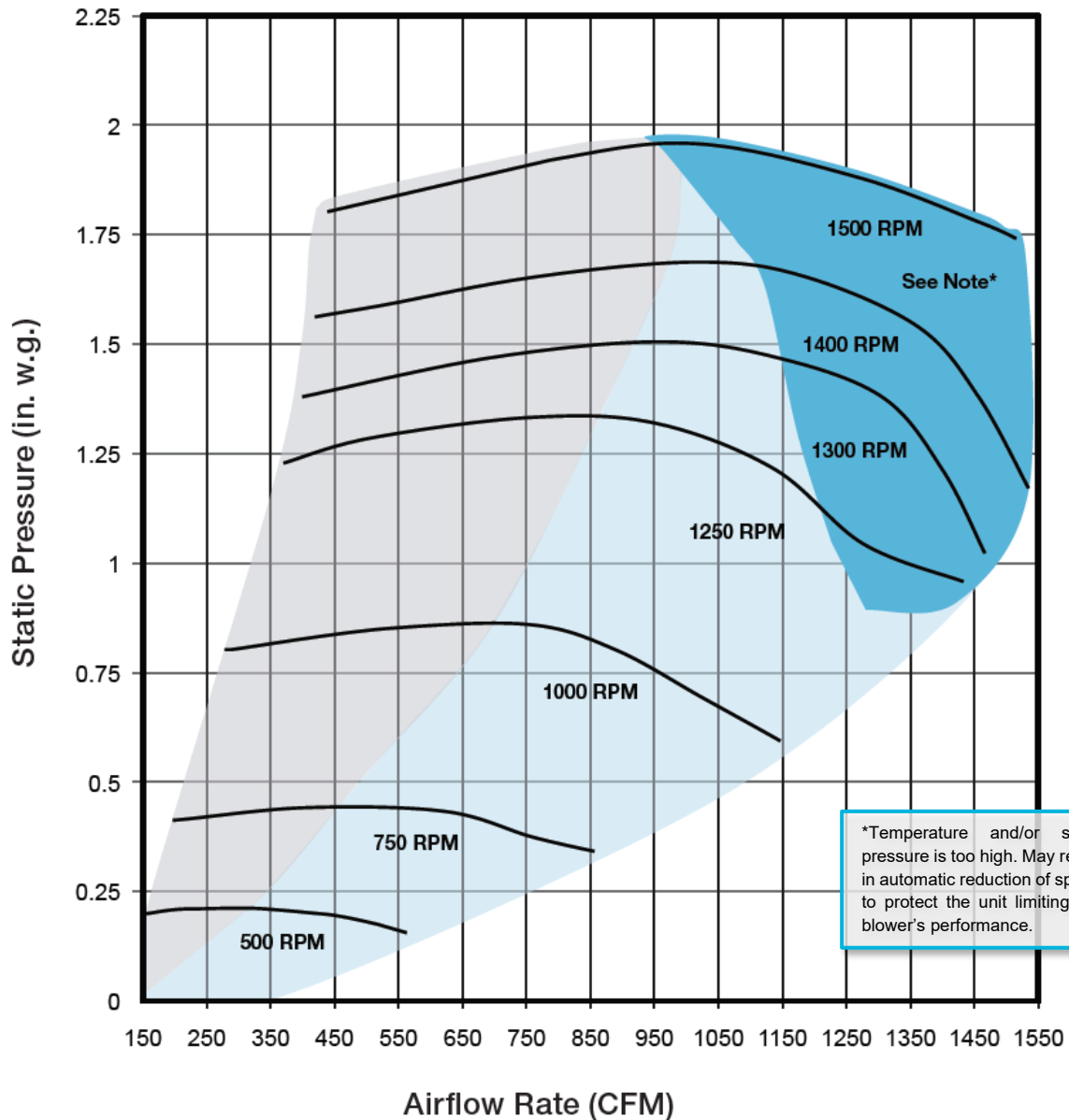

Speed (RPM)	Optimum Airflow (CFM) and Static Pressure (inches of water)	0-10 vdc Signal	4-20mA Signal
1500 MAX	900 CFM @ 1.9" to 1025 CFM @ 1.8"	9.0	20.0
1400	900 CFM @ 1.8" to 1180 CFM @ 1.7"	8.3	18.8
1250	850 CFM @ 1.37" to 1325 CFM @ 0.8"	7.4	16.9
1000	675 CFM @ 0.9" to 1100 CFM @ 0.6"	6.0	13.9
750	450 CFM @ 0.45" to 825 CFM @ 0.33"	4.4	10.9
500	300 CFM @ 0.20" to 550 CFM @ 0.12"	2.9	7.9
300	200 CFM @ 0.08" to 400 CFM @ 0.10"	1.8	5.5

12" Fiberglass or PVC, 2 HP VFD Motor

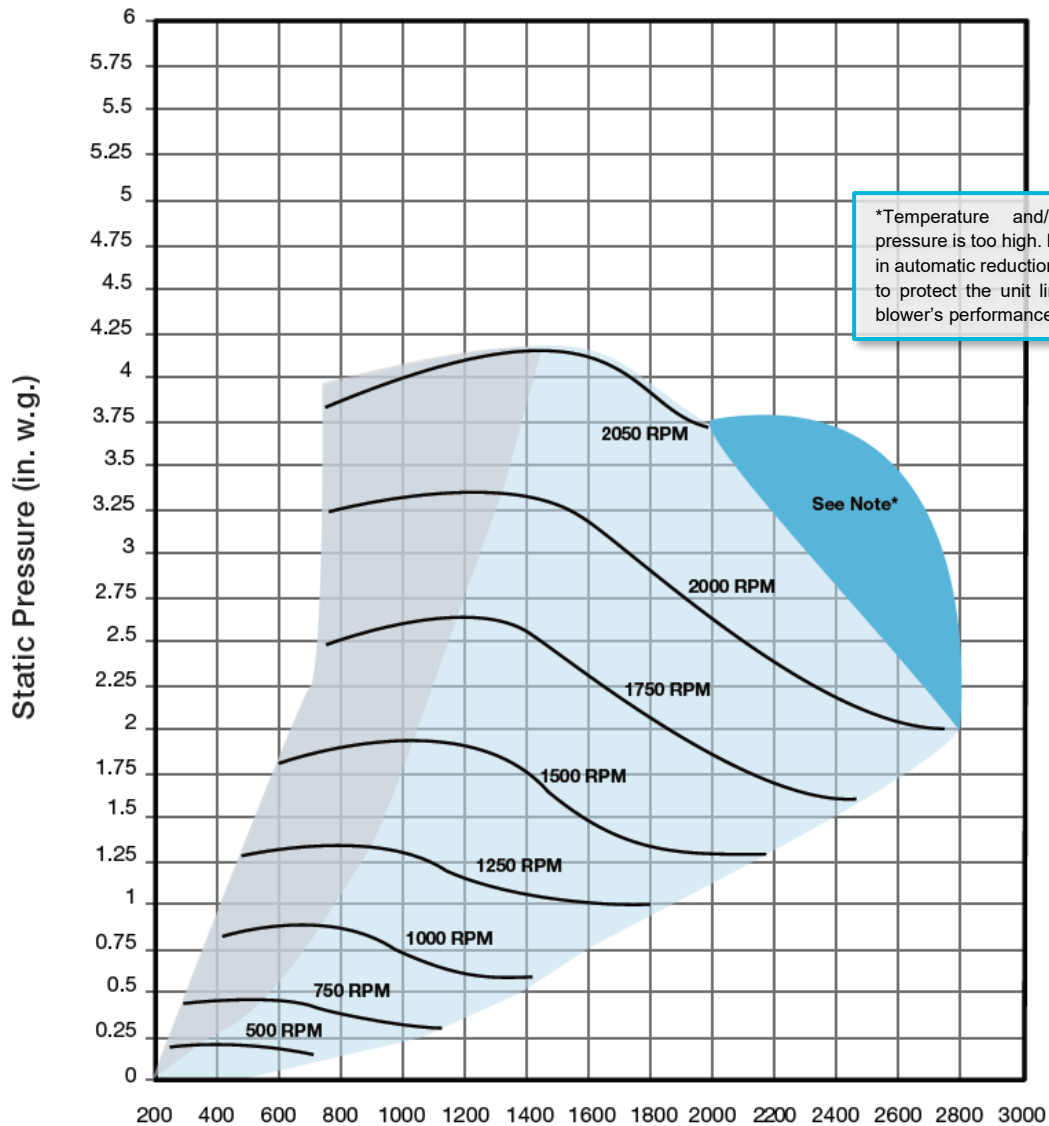

Airflow Rate (CFM)

Speed (RPM)	Optimum Airflow (CFM) and Static Pressure (inches of water)	0-10 vdc Signal	4-20mA Signal
2250 MAX	775 CFM @ 4.0" to 1481 CFM @ 4.1"	9.1	19.8
2000	769 CFM @ 3.2" to 2500 CFM @ 2.0"	8.1	18.0
1750	687 CFM @ 2.5" to 2533 CFM @ 1.6"	7.2	16.3
1500	564 CFM @ 1.8" to 2250 CFM @ 1.2"	6.3	14.5
1250	403 CFM @ 1.3" to 1794 CFM @ 0.9"	5.5	12.8
1000	329 CFM @ 0.8" to 1446 CFM @ 0.6"	4.5	11.0
750	251 CFM @ 0.4" to 1098 CFM @ 0.3"	3.7	9.3
500	173 CFM @ 0.2" to 674 CFM @ 0.1"	2.8	7.5

12" Coated Steel, 2 HP VFD Motor

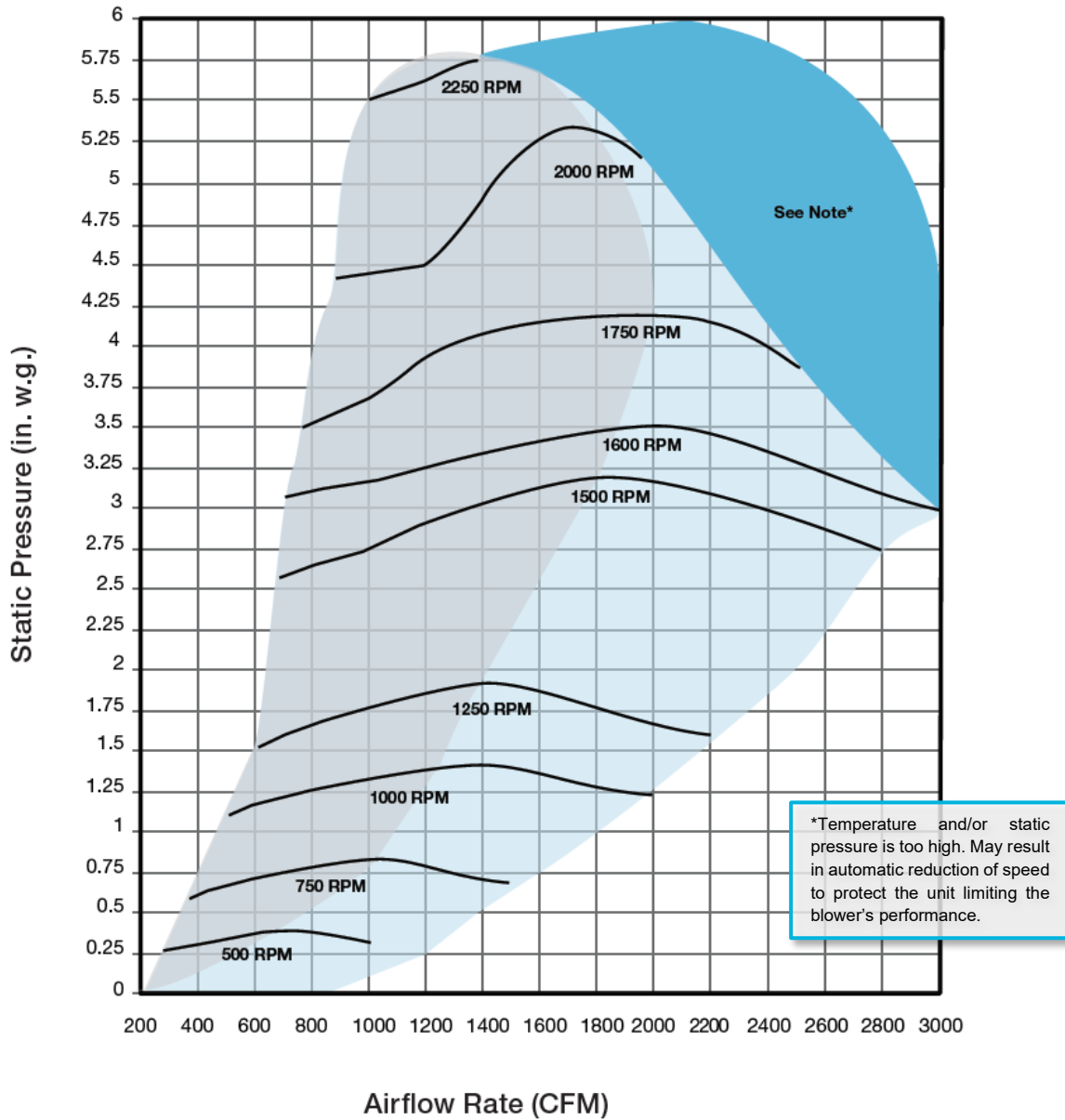

*Temperature and/or static pressure is too high. May result in automatic reduction of speed to protect the unit limiting the blower's performance.

Appendix E: Connecting the Spectrum Blower to a Guardian Digital AFM (Airflow Monitor)

The following section details how to connect a Spectrum Blower to a Guardian Digital Airflow Monitor. When complete, the Spectrum will be able to communicate to the user at the hood with the AFM. If in alarm, the AFM will show an alarm as 'External Alarm'. Once seen, it will be clear to the user to investigate further before continuing to operate the fume hood.



The Guardian Digital Airflow Monitor is shown in Figure E-1. If the airflow monitor installed on the hood is not a Guardian Digital AFM, this procedure will not work. Access to the roof top blower and behind the airflow monitor is required. Wire path running from Terminals 7 & 8 of the Spectrum Blower to the Guardian Digital AFM is required.



The following tools and materials are required to install the equipment:

- Guardian Digital AFM
- Wire path running from Spectrum Blower to AFM
- Small jeweler flathead screwdriver
- Phillips screwdriver
- Flathead screwdriver



The following safety precautions must be followed by all personnel installing the equipment.

- Wear safety glasses
- Wear gloves
- No loose fitting clothes
- Wear close-toed shoes
- Follow safe-lifting practices

Figure E-1



Step 1

Use a flat head screwdriver to remove 6 screws securing the access panel on the Spectrum Blower (Reference Figure 6-1). Pull away the panel to expose the controls display. Save this panel and hardware. Locate the 'Blower ON Output' Terminals 7 & 8 shown in Detail A of Figure E-2.

Step 2

Run wire from terminals 7 & 8 of spectrum blower to hood. Use jeweler screwdriver to open and close terminals. The entire length from the terminals to the fume hood mounted airflow monitor must be spanned by the wire used. Install and secure the wire in 'Blower ON Output' as shown in Figure E-1. Once wired and checked, reinstall the panel and screws.

Step 3

Now at the AFM on the hood, remove the side panel. Using a Phillips screwdriver, remove the screw on the top front of the side panel. Lift the side panel up to remove. Store the panel in a safe place and save all hardware. Using the control wires run from the blower on terminals 7 & 8, install them in the desired input. See Figure E-3 for wiring details. For this procedure, input 1 will be used as an example.

If the side of the hood is not accessible or if preferred, there is a secondary method. Using a Phillips screwdriver, remove the AFM from the corner post. Run the control wires from the blower on terminals 7 & 8 down the side of the hood and out the AFM mounting hole. Install them in the desired input and reinstall the airflow monitor. See Figure E-3

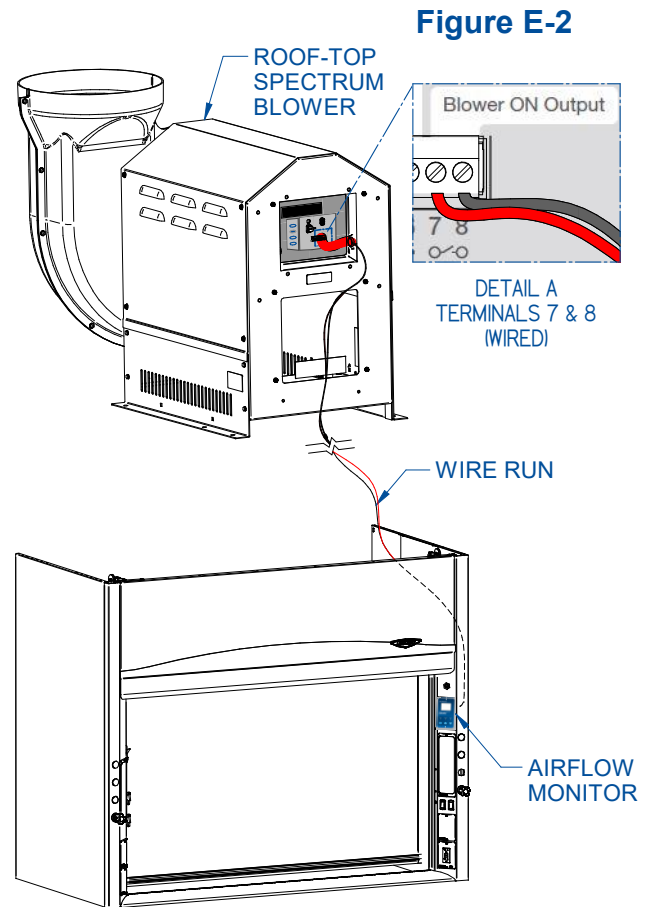

Figure E-2

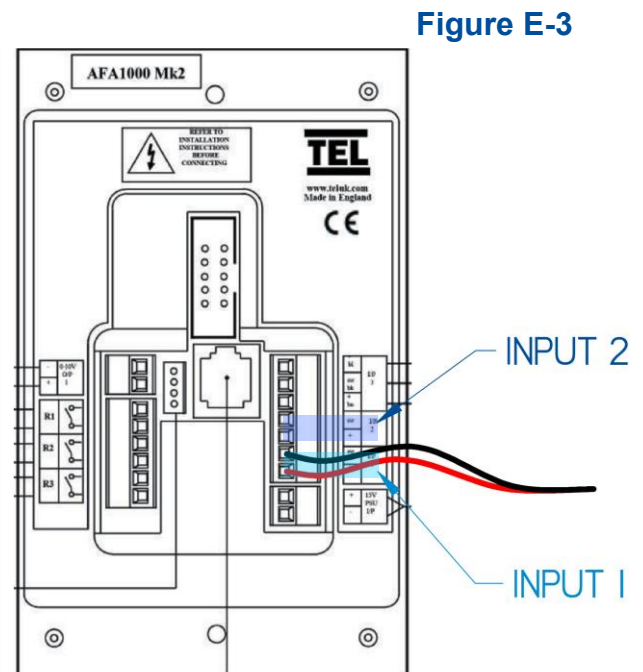

Figure E-3

for wiring details. For this procedure, input 1 will be used as an example.

Once properly wired, the AFM must be programmed to understand the communication being sent from the Spectrum blower. Using the Guardian Digital AFM, follow Steps 4 through 9.

Step 4

Press **[ENTER]** for 5 seconds to get main menu, then using the **[+/- ARROWS]** scroll until you find 'Set up' and press **[ENTER]**, then 'Configure' and press **[ENTER]**, a prompt to enter a password will show. The default password is 0000. If changed by the user, that password will need to be entered.

Figure E-4

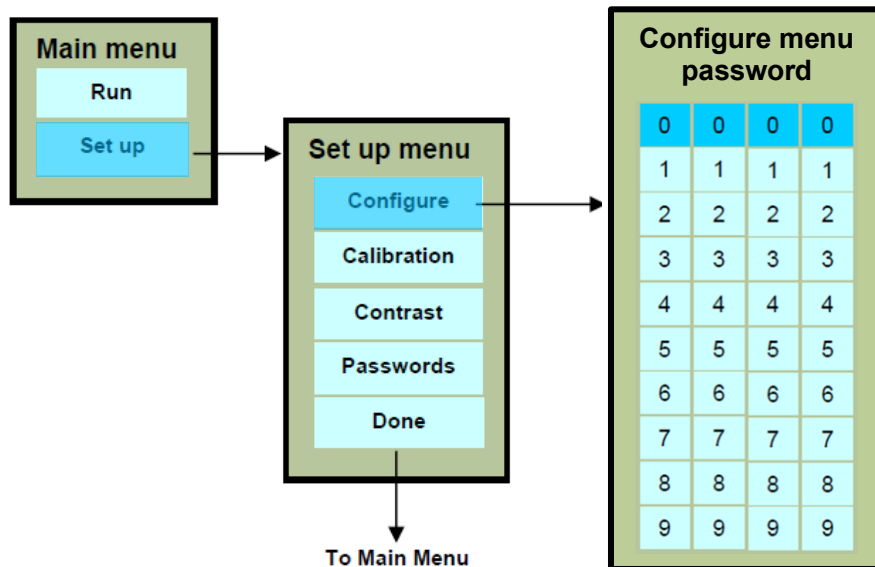

Step 5

Once successfully in the Configure Menu, find desired input used when wiring the Blower to the AFM and press **[ENTER]**. Change from 'Not active' to 'Activate on opening contact'.



It is very important that you select the option that activates when the contact **opens**. If the wrong activation is selected, the AFM will show an external alarm when the blower is operating without alarm.

Step 6

The display will automatically redirect to an input function menu. Scroll using the **[+/- ARROWS]** and press **[ENTER]** on 'External alarm'.

Step 7

This alarm has two notification options: a flashing red LED and displaying 'External alarm' on the screen. Set LED and Display icon to desired setting (either enabled or not). Labconco recommends enabling both.

Step 8

Select 'None' for output relay. It should be the default option.

Step 9

Now the display should be back on the Configure menu. Using the **[+/- ARROWS]** find 'Done' and press **[ENTER]**. The screen will return to the normal operating display as show in Figure E-1.

If the Spectrum Blower is ever in alarm, the notification methods selected in Step 7 will engage to warn the user to investigate the blower. See [Section 10: Troubleshooting](#) of this manual for more information on alarms.

Notes:

Notes:
