



**LABCONCO CORPORATION**

8811 Prospect Avenue  
Kansas City, MO 64132  
(800) 821-5525, (816) 333-8811  
(816) 363-0130 fax  
labconco@labconco.com

# User's Manual

## FreeZone<sup>®</sup> Bulk Tray Dryers

### Models

780601\*\*\* Series

To receive important product updates,  
complete your product registration card  
online at [register.labconco.com](https://register.labconco.com)

**Please read the User's Manual before operating the equipment.**

Copyright © 2018 Labconco Corporation. The information contained in this manual and the accompanying products are copyrighted and all rights reserved by Labconco Corporation. Labconco Corporation reserves the right to make periodic design changes without obligation to notify any person or entity of such change.

## **Warranty**

Labconco Corporation provides a warranty to the original buyer for the repair or replacement of parts and reasonable labor as a result of normal and proper use of the equipment with compatible chemicals. Broken glassware and maintenance items, such as filters, gaskets, light bulbs, finishes and lubrication are not warranted. Excluded from warranty are products with improper installation, erratic electrical or utility supply, unauthorized repair and products used with incompatible chemicals.

The warranty for FreeZone® Bulk Tray Dryers will expire one year from date of installation or two years from date of shipment from Labconco, whichever is sooner. Warranty is non-transferable and only applies to the owner (organization) of record.

Buyer is exclusively responsible for the set-up, installation, verification, decontamination or calibration of equipment. This limited warranty covers parts and labor, but not transportation and insurance charges. If the failure is determined to be covered under this warranty, the dealer or Labconco Corporation will authorize repair or replacement of all defective parts to restore the unit to operation. Repairs may be completed by 3<sup>rd</sup> party service agents approved by Labconco Corporation. Labconco Corporation reserves the rights to limit this warranty based on a service agent's travel, working hours, the site's entry restrictions and unobstructed access to serviceable components of the product.

Under no circumstances shall Labconco Corporation be liable for indirect, consequential, or special damages of any kind. This warranty is exclusive and in lieu of all other warranties whether oral, or implied.

## **Returned or Damaged Goods**

Do not return goods without the prior authorization from Labconco. Unauthorized returns will not be accepted. If your shipment was damaged in transit, you must file a claim directly with the freight carrier. Labconco Corporation and its dealers are not responsible for shipping damages.

The United States Interstate Commerce Commission rules require that claims be filed with the delivery carrier within fifteen (15) days of delivery.

## **Limitation of Liability**

The disposal and/or emission of substances used in connection with this equipment may be governed by various federal, state, or local regulations. All users of this equipment are required to become familiar with any regulations that apply in the user's area concerning the dumping of waste materials in or upon water, land, or air and to comply with such regulations. Labconco Corporation is held harmless with respect to user's compliance with such regulations.

## **Contacting Labconco Corporation**

If you have questions that are not addressed in this manual, or if you need technical assistance, contact Labconco's Customer Service Department or Labconco's Product Service Department at 1-800-821-5525 or 1-816-333-8811, between the hours of 7:30 a.m. and 5:30 p.m., Central Standard Time.

---

# TABLE OF CONTENTS

<b>CHAPTER 1: INTRODUCTION</b>	1
Intended Use	1
Freeze Dry Process	1
Freeze Dry Rates	1
Freeze Dry Capacity	3
Samples Containing Volatile Substances	3
About This Manual	4
Typographical Conventions	5
<b>CHAPTER 2: PREREQUISITES</b>	6
Electrical Requirements	6
Location Requirements	7
Vacuum Pump Requirements	7
<b>CHAPTER 3: GETTING STARTED</b>	8
Unpacking Your Bulk Tray Dryer	8
Bulk Tray Dryer Components	9
Setting Up Your Bulk Tray Dryer	9
Installing the Tray Dryer on the Freeze Dryer	9
Electrical Connection	10
Communication Cable	10
Ground Strap	10
Testing System Vacuum Integrity	11
Venting the Vacuum Pump	11
Chemical Resistance of Freeze Dryer Components	11
Solvent Safety Precautions	13
<b>CHAPTER 4: USING YOUR BULK TRAY DRYER</b>	14
Component Identification	15
Operation Checklist	16
Operating the Bulk Tray Dryer	17
Drying Accessory Screen	18
Manual Mode	19
Starting Manual Mode	19
Changing Shelf Temp Set Point Value	20
Stopping Manual Mode	20

Programs	21
Creating a New Program	22
Starting a Program	23
Stopping a Program	23
Freeze Drying Using the Manifold Valves	24
Alerts	25
Power Fail	26
Shelf Temp Variation	26
Shelf Temp Set Point	26
Program Complete	26
<b>CHAPTER 5: MAINTAINING YOUR BULK TRAY DRYER</b>	27
Service Safety Precautions	27
Routine Maintenance Schedule	27
Decontamination	28
<b>CHAPTER 6: TROUBLESHOOTING</b>	29
Vacuum Pump	29
Gaskets, Tubing, Connections, Sample Valves	30
System Components & Collector Chamber Isolation	31
Bulk Tray Dryer	33
Door Adjustment	33
<b>APPENDIX A: COMPONENTS</b>	35
<b>APPENDIX B: DIMENSIONS</b>	37
<b>APPENDIX C: SPECIFICATIONS</b>	39
Electrical Specifications	39
Environmental Conditions	39
<b>APPENDIX D: ACCESSORIES</b>	40

---

# Chapter 1:

## Introduction

Congratulations on your purchase of a Labconco FreeZone® Bulk Tray Dryer, which is designed for laboratory lyophilization procedures. The unit is easy to install and maintain. Proper care and maintenance of this product will result in many years of dependable service.

### Intended Use

The Bulk Tray Dryer is intended to be used in conjunction with Labconco Console Freeze Dryers in a laboratory setting to facilitate the lyophilization process.

### Freeze Dry Process

Freeze drying is an important process in sample preparation and for the preservation and storage of biologicals, pharmaceuticals and foods. Of the various methods of dehydration, freeze drying (lyophilization) is especially suited for substances that are heat sensitive. Other than food processing (e.g., coffee, whole dinners), freeze drying has been extensively used in the development of pharmaceuticals (e.g., antibiotics) and preservation of biologicals (e.g., proteins, plasma, viruses and cell lines). The nondestructive nature of this process has been demonstrated by the retention of viability in freeze dried viruses and microorganisms.

Freeze drying is a process whereby water or other solvent is removed from frozen material by converting the frozen water directly into vapor without the intermediate formation of liquid water. The basis for this sublimation process involves the absorption of heat by the frozen sample in order to vaporize the ice; the use of a vacuum pump to enhance the removal of water vapor from the surface of the sample; the transfer of water vapor to a collector; and the removal of heat by the collector in order to condense the water vapor. In essence, the freeze dry process is a balance between the heat absorbed by the sample to vaporize the ice and the heat removed from the collector to convert the water vapor into ice.

### Freeze Dry Rates

The efficiency of the freeze drying process is dependent upon the surface area and the thickness of the sample, the collector temperature and vacuum obtained, the eutectic point and solute concentration of the sample. It is important to remember these factors when trying to obtain efficient utilization of your Freeze Dryer. A listing of selected materials and their approximate drying times are shown in Table 1 for your reference.

## Chapter 1: Introduction

SAFE TEMPERATURE AND DRYING TIMES FOR SELECTED MATERIALS			
Material 10mm Thick	Safe Temp °C	Collector Temp °C	Hours (Approx.)
Milk	-5	-40	10
Urea	-7	-40	10
Blood Plasma	-10 to -25	-40	16
Serum	-25	-40	18
Vaccinia	-30 to -40	-50	22
Influenza Vaccine	-30	-50	24
Human Tissue	-30 to -40	-50	48
Vegetable Tissue	-50	-80	60

\*Total sample quantities are contingent on various freeze dryer capacities.

Up to the point of overloading the system, the greater the surface area of the sample, the faster the rate of freeze drying. By contrast, for a given surface area, the thicker the sample the slower the rate of freeze drying. This is based on the fact that the heat of sublimation is usually absorbed on one side of the frozen sample and must travel through the frozen layer to vaporize water at the other surface. In addition, as the sample is freeze dried, the water vapor must travel through the layer of dried material. The thicker the sample, the greater the chance that the dried layer may collapse which would cause an additional decrease in the rate of freeze drying.

The surface area and thickness of the sample can usually be ignored when each sample contains only a few milliliters. However, for larger volumes, the samples should be shell frozen to maximize the surface area and minimize the thickness of the sample. The volume of the freeze dry flask should be two to three times the volume of the sample.

In order for lyophilization to occur, ice must be removed from the frozen sample via sublimation. This is accomplished by the collector and the vacuum pump. The collector, which should be at least 15 to 20°C colder than the eutectic temperature (melting temperature) of the sample, traps vapor as ice. Since the vapor pressure at the collector is lower than that of the sample, the flow of water vapor is from the sample to the collector. Since this vapor diffusion process occurs very slowly under normal atmospheric conditions, a good vacuum is essential to maintain an efficient rate. In many applications, the maintenance of a vacuum of 0.133 mbar or less is recommended.

The rate of freeze drying is directly proportional to the vapor pressure and the vapor pressure is dependent upon both eutectic temperature and solute concentration of the sample. For example, a solution of sodium chloride and water would freeze dry at a slower rate than pure water. The eutectic temperature of a sodium chloride solution is about -21°C and at this temperature the vapor pressure is about 1/16 that of water at 0°C. Although the eutectic temperature is not dependent upon the concentration of sodium chloride, the vapor pressure of the water would decrease as the concentration of sodium chloride increased. This is due to the fact that as the solute concentration increases, less of the surface area of the frozen sample is occupied by water. In general, most solutions or biological samples will have a eutectic temperature of -10° to -25°C. However, if the sample contains a simple sugar such as glucose or if the sample is animal or plant tissue, the eutectic temperature may be as low as -30° to -50°C.

## Freeze Dry Capacity

The volume of a sample that can be freeze dried at one time is related to factors discussed previously and the size and design of the Freeze Dryer. With any given instrument, the capacity is based on the surface area of the sample, the eutectic temperature and concentration of the sample and the rate and amount of heat transferred to the frozen sample. Of these factors, the eutectic temperature is the most important factor in determining the amount of sample that can be freeze dried at one time, particularly when flasks are used on the optional 6-Port Manifold. This is because as the eutectic temperature decreases, the vapor pressure decreases but the rate of heat absorption by the sample does not change. This tends to promote melting of the sample, which leads to a marked increase in vapor pressure and ultimately overloads the collector and vacuum pump. Samples that have eutectic temperatures of  $-20^{\circ}\text{C}$  or lower should be placed on 6-Port Manifold one flask at a time so that the vacuum in the system may recover before adding another sample to the system. If the vacuum does not recover, the capacity of the Freeze Dryer has been exceeded and the sample should be removed. This can also happen when too many samples are placed into the Bulk Tray Dryer chamber.

If there is a problem with a particular type of sample melting when placed in the Bulk Tray Dryer chamber, dilution of the sample with water (prior to pre-freezing) or decreasing the shelf set point temperature to decrease the rate of heat absorption by the sample may help. If sample melting occurs when freeze drying flasks on the 6-Port Manifold, dilution of the sample with water (prior to pre-freezing) or providing some insulation around the flask to decrease the rate of heat absorption by the sample may help. If the eutectic temperature of the sample is  $-40$  to  $-60^{\circ}\text{C}$ , the Freeze Dryer selected for use must be equipped with cascade type refrigeration so that the collector temperature can be cooled to below  $-75^{\circ}\text{C}$ , or a dry ice/solvent trap may be used between the collector and the vacuum pump.

## Samples Containing Volatile Substances

In certain cases the solvent in a sample to be freeze dried may contain volatile components such as acetonitrile, methanol, acetic acid, formic acid or pyridine. In addition to these substances having an effect on the eutectic temperature, they may increase the vapor pressure at the surface of the sample. Also, compared to water, they will require the absorption of less heat for sublimation to occur. Hence, samples that contain volatile substances will have a greater tendency to melt, particularly when placed in flasks or exposed to room temperature. If a sample containing a volatile substance tends to melt when placed on a Freeze Dryer, dilution of the sample with more water will help keep the sample frozen. For example, a 0.2M solution of acetic acid is much easier to freeze dry than a 0.5M solution.

## About This Manual

This manual is designed to help you learn how to install, use, and maintain your Bulk Tray Dryer. Instructions for performing routine maintenance and making minor modifications to your Bulk Tray Dryer are also included.

*Chapter 1: Introduction* provides a brief overview of the Bulk Tray Dryer, explains the organization of the manual, and defines the typographical conventions used in the manual.

*Chapter 2: Prerequisites* explains what you need to do to prepare your site before you install your *Bulk Tray Dryer*. Electrical requirements are discussed.

*Chapter 3: Getting Started* contains the information you need to properly unpack, inspect and install your Bulk Tray Dryer.

*Chapter 4: Using Your Bulk Tray Dryer* discusses the basic operation of your Bulk Tray Dryer. Information on how to load or attach samples and run the Bulk Tray Dryer is included.

*Chapter 5: Maintaining Your Bulk Tray Dryer* explains how to perform routine maintenance on your Bulk Tray Dryer.

*Chapter 6: Troubleshooting* contains a table of problems you may encounter while using your Bulk Tray Dryer, including the probable causes of the problems, and suggested corrective actions.

*Appendix A: Components* contains labeled diagrams of the components of the Bulk Tray Dryer.

*Appendix B: Dimensions* contains diagrams showing the dimensions for the *Bulk Tray Dryer*.

*Appendix C: Specifications* contains product specifications.

*Appendix D: Accessories* see [www.labconco.com](http://www.labconco.com) for a complete list of Bulk Tray Dryer accessories.

# Typographical Conventions

Recognizing the following typographical conventions will help you understand and use this manual:

- Book, chapter, and section titles are shown in italic type (e.g., *Chapter 3: Getting Started*).
- Steps required to perform a task are presented in a numbered format.
- Comments located in the margins provide suggestions, reminders, and references.
- Critical information is presented in boldface type in paragraphs that are preceded by the exclamation icon. Failure to comply with the information following an exclamation icon may result in injury to the user or permanent damage to your Freeze Dryer or Bulk Tray Dryer.
- Important information is presented in capitalized type in paragraphs that are preceded by the pointer icon. It is imperative that the information contained in these paragraphs be thoroughly read and understood by the user.

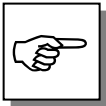

## Chapter 2:

# Prerequisites

Before you install your Bulk Tray Dryer, you need to prepare your site for installation. The Bulk Tray Dryer will mount on top of a FreeZone 6, 12 or 18 liter Freeze Dryer. Carefully examine the location where you intend to install your Bulk Tray Dryer. You must be certain that the area is level and of solid construction. An electrical source must be located near the installation site.

Carefully read this chapter to learn:

- The electrical supply requirements.
- The vacuum pump requirements.

Refer to *Appendix C: Specifications* for complete Bulk Tray Dryer electrical and environmental conditions, specifications and requirements.

Refer to the User's Manual for the FreeZone Freeze Dryer for complete electrical and environmental conditions, specifications and requirements.

## Electrical Requirements

- 115V models
  - 15 Amp single phase circuit.
  - Properly grounded receptacle for NEMA 5-15P plug.

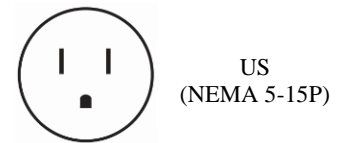

- 230V models
  - 8 Amp single phase circuit.
  - Properly grounded receptacle that matches the plug supplied with the unit, (230V models are supplied with one of the following plugs):

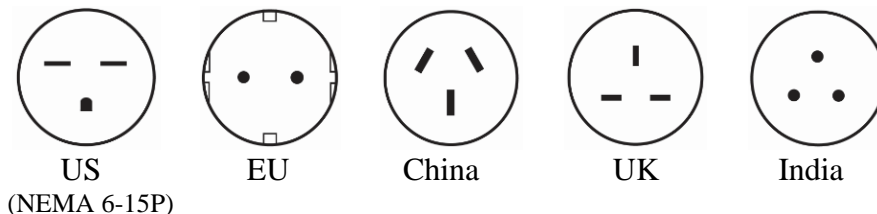

- If the plug does not match the available receptacle, remove the plug and replace it with an approved plug of the suitable style.



**Do not use any detachable power cord that is not adequately rated for the unit.**

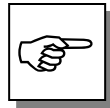

**ADDITIONAL APPLIANCES ON THE SAME CIRCUIT MAY CAUSE THE CURRENT TO EXCEED THE RATING OF THE CIRCUIT BREAKER OR FUSE.**

## Location Requirements

The Freeze Dryer should be located in an area that provides an unobstructed flow of air around the cabinet. This air cools the refrigeration system. A minimum of 3" must be allowed between the rear and both sides of the Freeze Dryer and adjacent wall surfaces. Restriction of airflow during operation could adversely affect performance. Refer to *Appendix B: Dimensions* for dimensional drawings of the Bulk Tray Dryer.

## Vacuum Pump Requirements

A vacuum pump must be provided by the user. A vacuum pump with a displacement of 163 liters per minute and 0.007 mbar ultimate pressure is adequate for most samples. The inlet fitting on the vacuum pump must be suitable for 3/4" ID vacuum hose, which is provided with the FreeZone Freeze Dryer. It is recommended that the vacuum pump is equipped with an exhaust filter to minimize oil mist exhausting from the vacuum pump. The operating vacuum level may be set on the freeze dryer system. The higher the pressure is set, the more likely it is that oil mist will be exhausted.

Vacuum pumps used with 115V models should be equipped with a 115V, 15 Amp NEMA 5-15P plug. Vacuum pumps used with 230V models should be equipped with a reverse IEC plug (included with 230V pumps purchased from Labconco). This will allow the vacuum pump to be plugged into the receptacle on the back panel of the Console Freeze Dryer.

## Chapter 3: Getting Started

Now that the site for your Bulk Tray Dryer is properly prepared, you are ready to unpack, inspect, install and test your Bulk Tray Dryer. Read this chapter to learn how to:

- Unpack and move your Bulk Tray Dryer.
- Set up your Bulk Tray Dryer.
- Connect the electrical supply source to your Bulk Tray Dryer.
- Safely use solvents with your Bulk Tray Dryer.



**The Bulk Tray Dryer can weigh up to 235 lbs. (107 Kg). The carton allows for lifting with a mechanical lift truck or hand truck. If you must lift the Bulk Tray Dryer manually, use at least two (2) persons and follow safe lifting guidelines.**

## Unpacking Your Bulk Tray Dryer

Carefully unpack your Bulk Tray Dryer and inspect it for damage that may have occurred in transit. If your Bulk Tray Dryer is damaged, notify the delivery carrier immediately and retain the entire shipment intact for inspection by the carrier.

*The United States Interstate Commerce Commission rules require that claims be filed with the delivery carrier within fifteen (15) days of delivery.*

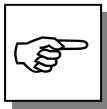

**DO NOT RETURN GOODS WITHOUT THE PRIOR AUTHORIZATION OF LABCONCO. UNAUTHORIZED RETURNS WILL NOT BE ACCEPTED.**

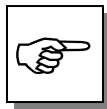

**IF YOUR BULK TRAY DRYER WAS DAMAGED IN TRANSIT, YOU MUST FILE A CLAIM DIRECTLY WITH THE FREIGHT CARRIER. LABCONCO CORPORATION AND ITS DEALERS ARE NOT RESPONSIBLE FOR SHIPPING DAMAGE.**

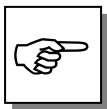

**DO NOT DISCARD THE CARTON OR PACKING MATERIAL FOR YOUR BULK TRAY DRYER UNTIL YOU HAVE CHECKED ALL OF THE COMPONENTS AND INSTALLED AND TESTED THE FREEZE DRYER.**

## Bulk Tray Dryer Components

Verify that the components listed are present and undamaged.

Part #	Qty.	Component Description	Comments
1089005	1	User's Manual	<i>USB Flash Drive</i>
7364601	1	Cable, Communication	
1880712	4	Screw 1/4-20 x .75	
1905621	4	Nut 1/4-20	
1911416	8	Washer 1/4"	
	1	Power Cord	<i>See parts list (Appendix A)</i>

If you did not receive one or more of the components listed for your Bulk Tray Dryer, or if any of the components are damaged, contact Labconco Corporation immediately for further instructions.

## Setting Up Your Bulk Tray Dryer

After you verify receipt of the proper components, move your Bulk Tray Dryer to the location where you want to install it. Then, follow the steps listed below.

### Installing the Tray Dryer on the Freeze Dryer

The following tools are required to install the Bulk Tray Dryer onto a FreeZone Freeze Dryer: Flat blade screw driver or 5/16" socket and a 7/16" wrench or socket.

Remove the four plastic hole plugs from the top of the Freeze Dryer on which the Bulk Tray Dryer is to be mounted. If the Freeze Dryer has a flat gasket around the 3.0 inch vacuum port, remove it. Loosen both clamps on the lower rubber coupling and slide the coupling upward so the bottom of the coupling is above the lower edge of the stainless steel tube. Snug both clamps on the couplings to hold them in place.

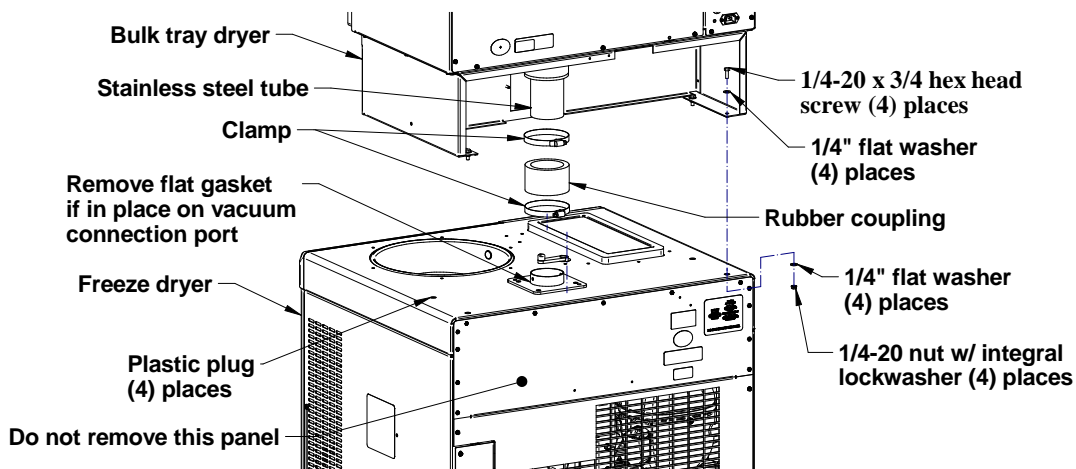

## Chapter 3: Getting Started

Lift the Bulk Tray Dryer into place on your Freeze Dryer while centering the vacuum coupling over the vacuum connection port. Align the four mounting holes in the Bulk Tray Dryer support stand with the four holes in the top of the Freeze Dryer.



**Do not lift the Bulk Tray Dryer by the acrylic door**

Install the four bolts, nuts, and washers provided. Loosen the clamps and slide the lower rubber coupling down over the vacuum connection port. Orient the clamps to gain access and tighten the clamps to provide a leak-free connection.

### Electrical Connection

Plug the power cord into the receptacle on the back of the Bulk Tray Dryer and plug the other end into a suitable power receptacle. Make sure that the outlet that you intend to use meets the voltage and amperage requirements listed on the serial tag of the Bulk Tray Dryer.



**Do not attempt to plug the power cord from the Bulk Tray Dryer into the FreeZone Freeze Dryer.**

### Communication Cable

The Freeze Dryer power cord should be unplugged before connecting the communication cable. Connect one end of the communication cable (7364600) to the port on the back panel of the Bulk Tray Dryer labeled “OUTPUT TO FREEZE DRYER”. Connect the other end of the cable to the port on the Freeze Dryer labeled “DRYING ACCESSORY”. Plug the Freeze Dryer power cord back into a suitable power receptacle.

### Ground Strap

Connect the Ground Strap by removing one of the screws from the Freeze Dryer back panel and attaching the free end of the Ground Strap.

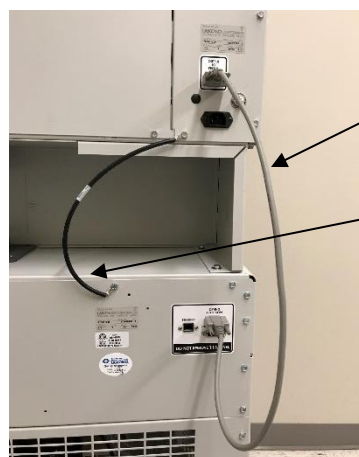

Communication  
Cable

Ground  
Strap

## Testing System Vacuum Integrity

The Bulk Tray Dryer is now installed and must be tested to make certain the system is free of leaks. Refer to Chapter 4 on how to operate the Bulk Tray Dryer. To test the vacuum integrity of the system, turn on the Freeze Dryer refrigeration and allow the temperature to reach  $-40^{\circ}\text{C}$  or lower. Close and latch the door of the Bulk Tray Dryer. Make sure that the “Vac Release” valve is in the “CLOSE” position. Start the vacuum pump and monitor the vacuum gauge. The vacuum on the Freeze Dryer should reach 0.133 mbar within 30 minutes and should achieve an ultimate vacuum of 0.040 mbar or lower within 18 hours.

If 0.040 mbar cannot be achieved, consult the troubleshooting section of this manual and of the manual supplied with the Freeze Dryer.

## Venting the Vacuum Pump



**If any materials will be placed in the Bulk Tray Dryer that can liberate hazardous gases when heated, the vacuum pump exhaust must be vented to a fume hood or other ventilation device.**

## Chemical Resistance of Freeze Dryer Components

The FreeZone Freeze Dryer and Bulk Tray Dryer are designed to be chemically resistant to most compounds that are commonly used in freeze drying processes. However, by necessity, the Freeze Dryer is comprised of a number of different materials, some of which may be attacked and degraded by certain chemicals. The degree of degradation is dependent on the concentration and exposure duration. Some of the major components of the FreeZone Freeze Dryer that are susceptible to degradation are as follows:

## Chapter 3: Getting Started

Component	Material	Acids			Buffers		Solvents						
		Acetic Acid 20%	Formic Acid	Trifluoroacetic Acid (TFA)	Calcium Chloride	Sodium Phosphate	Acetone	Acetonitrile	Carbon Tetrochloride	Cyclohexane	Dioxane	Methyl t-Butyl Ether (BTBE)	Pyridine
Valve Stem	Acetal	C	D	D	D		D						
Collector*	Acrylic			D			D	D	D				
Lid & Door													
Hoses, Gaskets & Valve Bodies	Neoprene	C	D	D			C	C	D	D	D	C	D
Flask Top	Silicon Rubber		C	D		D			D	D	D	C	D
Chamber & Fittings	Stainless Steel				C								

\* An accessory glass lid is available for the Freeze Dry base units.

C – Moderate degradation; Limited use.

D – Severe degradation; infrequent use recommended; immediate thorough cleaning required.

- Most common compounds used in freeze drying processes, if allowed to enter the vacuum pump, will degrade the oil and cause damage to the vacuum pump.
- Sugars and proteins typically will have minimal negative effect on any of the materials of construction.

When using compounds in the Freeze Dryer that are hostile to the materials of construction, it is imperative the equipment is thoroughly cleaned after use.

- Rubber and plastic components that have been exposed to damaging compounds should be removed and flushed with water.
- The oil in the vacuum pump should be checked often. It must be changed if it is cloudy, shows particles or is discolored. The useful life of vacuum pump oil can be extended if the vacuum pump is operated for an extended period of time after a freeze dry run. This allows contaminants to be purged from the hot oil. This must be done with the inlet to the pump blocked off to prevent air from free flowing through the pump. This is accomplished by closing all sample valves on a clean, dry Freeze Dryer and turning on the vacuum pump. If the pump is operated at an elevated vacuum level (> 10mbar), oil may be expelled from the pump and damage could occur.

Another way to extend the life of the vacuum pump is to install an optional secondary trap in the line between the Freeze Dryer and the vacuum pump. Contact Labconco for ordering information.

With prudent maintenance the FreeZone Freeze Dryer will provide years of service. Warranty on the affected parts will be voided if maintenance has been obviously neglected. If you have questions about using specific compounds in the Freeze Dryer, contact Labconco Technical Service at 1-800-821-5525 or 816-333-8811 or e-mail: [labconco@labconco.com](mailto:labconco@labconco.com).



## Solvent Safety Precautions

**Solvents used in the Bulk Tray Dryer may be flammable or hazardous to your health. Use extreme caution and keep sources of ignition away from the solvents. When using flammable or hazardous solvents, the vacuum pump must be vented to a fume hood.**

**Hazardous materials such as strong acids or bases, radioactive substances and volatile organics must be handled carefully and promptly cleaned up if spilled. If a sample is spilled in the collector chamber it must immediately be cleaned up.**

**WARNING: The disposal of substances used in connection with this equipment may be governed by various Federal, State or local regulations. All users of this equipment are urged to become familiar with any regulations that apply in the user's area concerning the dumping of waste materials in or upon water, land or air and to comply with such regulations.**

---

## Chapter 4:

# Using Your Bulk Tray Dryer

After your Bulk Tray Dryer has been installed as detailed in Chapter 3: Getting Started, you are ready to begin using your Bulk Tray Dryer. Read this chapter to learn how to:

- Operate the controls.
- Understand the display.
- Connect samples.



**Do not use the Bulk Tray Dryer in a manner not specified by the manufacturer (refer to *Appendix C: Specifications*). The electrical protection properties of the Bulk Tray Dryer may be impaired if the Bulk Tray Dryer is used inappropriately.**

## Component Identification



## Chapter 4: Using Your Bulk Tray Dryer

---

**Power Switch** - Located on left side of cabinet. Turns all AC power to the Bulk Tray Dryer ON or OFF.

**POWER / STANDBY LED Indicator** – Indicates if the power switch is ON or OFF.

**IN PROCESS LED Indicator** – This light will be ON if the Bulk Tray Dryer is running in either MANUAL or PROGRAM mode.

**Vacuum Release Valve** - Vents the chamber so the chamber door can be opened.

## Operation Checklist

The following checklist should be followed prior to each use of your Bulk Tray Dryer.

1. Wipe out the interior of the Bulk Tray Dryer chamber with a soft cloth or paper towel to remove any moisture or debris.
2. Ensure that the Freeze Dryer collector chamber and drain line are free of water. Place the drain hose in a suitable container to collect the condensate from the collector chamber. Insert the quick connect drain fitting into the quick connect drain coupling located on the console's front right. If the Freeze Dryer is equipped with the Shell Freezer option, the lower drain coupling is used to drain the collector chamber and the upper is used to drain the Shell Freezer. **Note: Freeze Dryer (Collector or Vacuum) will not start if moisture is detected in the drain line.**
3. After completely draining the system, disconnect the quick connect drain fitting from the quick connect drain coupling.

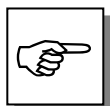

**DISCONNECT THE QUICK CONNECT DRAIN FITTING BEFORE STARTING THE VACUUM PUMP. FAILURE TO REMOVE THE FITTING WILL RESULT IN A LARGE VACUUM LEAK.**

4. Wipe the interior of the collector chamber of the Freeze Dryer with a soft cloth or paper towel to remove any accumulated moisture.
5. Using a soft, lint-free cloth or paper towel, wipe the Freeze Dryer collector chamber lid gasket and the Bulk Tray Dryer door gasket to remove any dirt and contaminants that could cause a vacuum leak. Vacuum grease is not required on the door gasket to obtain a proper vacuum seal.
6. If the optional 6-Port manifold accessory is installed on your Bulk Tray Dryer, make sure that each sample valve is in either the “closed” or “vent” position.

## Operating the Bulk Tray Dryer

1. Adjust the shelf spacing - Prior to loading the shelves with the product to be freeze dried, adjust the shelf spacing to accommodate the size and quantity of the samples. The Bulk Tray Dryer comes equipped with three heated shelves and two additional accessory shelves may be added. At least one shelf must be used and any number of shelves up to five may be used. Shelves may be connected at any of the five available positions. Be certain to push the shelf to the back of the chamber until the electrical connector is fully engaged to ensure a positive electrical connection to the heaters.
2. Temperature Sensors – Each shelf is equipped with a “Shelf” sensor that is used to accurately control the temperature of the shelf. A “Sample” sensor can also be plugged into the two pin connector at the front of the shelf that can be used to monitor the sample temperature during the freeze drying process. The sensors will be displayed as Shelf 1, 2, 3, 4, & 5 and Sample 1, 2, 3, 4, & 5 on the Freeze Dryer touch screen.
3. Freeze the Sample - Before the freeze dry process can occur the product must be in a frozen state. This must be done in a freezer separate from the Bulk Tray Dryer.
4. Start the Freeze Dryer - Turn ON the Freeze Dryer COLLECTOR and allow the collector to cool to  $-40^{\circ}\text{C}$  or below.
5. Turn ON the Bulk Tray Dryer by toggling the power switch located on the left side of the unit. The POWER/STANDBY LED on the front of the unit will turn ON.
6. Position the Vacuum Release valve to “CLOSE”.
7. Load Samples- Position samples on the shelves inside the Bulk Tray Dryer. Close the door and rotate the handle  $180^{\circ}$  to latch the door. **SAMPLE MAY BE LOADED AFTER THE FREEZE DRYER COLLECTOR TEMPERATURE REACHES  $-40^{\circ}\text{C}$  OR COLDER.** If the collector is not cold when the samples are loaded (and the freeze dry process is started), water vapor will bypass the collector and go into the vacuum pump. This will contaminate the pump oil and can cause premature failure of the vacuum pump.
8. Turn ON the vacuum pump.
9. Start the Bulk Tray Dryer in either MANUAL or PROGRAM mode to control the shelf temperature to a set point value.

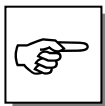

ALL ELECTRONIC CONTROL OF THE BULK TRAY DRYER WILL BE DONE BY USING THE TOUCH SCREEN DISPLAY ON THE FREEZE DRYER BELOW THE BULK TRAY DRYER.

## Chapter 4: Using Your Bulk Tray Dryer

The main features that are used to control the Bulk Tray Dryer will be described in this manual. For a complete description of the Freeze Dryer operating system, consult the Freeze Dryer User's Manual.

### Drying Accessory Screen

If the Bulk Tray Dryer is NOT connected to the Freeze Dryer (via the communication cable), the Drying Accessory icon will NOT appear in the main menu bar. If the Bulk Tray Dryer has been properly connected to the Freeze Dryer, the Drying Accessory icon will appear in the main menu bar and you will be able to control and monitor the Drying Accessory from this screen.

The screenshot shows the 'Drying Accessory' screen with a navigation bar at the top containing icons for home, messages, folders, settings, a drying accessory, a cable, a network, and help. The main content area features a table with the following data:

Name	Value	Name	Value
Shelf 1	24.1°C	Sample 1	23.8°C
Shelf 2	---	Sample 2	---
Shelf 3	24.0°C	Sample 3	23.7°C
Shelf 4	---	Sample 4	---
Shelf 5	24.2°C	Sample 5	23.8°C

Below the table, the status box shows 'Drying Accessory OFF' on the left and 'Data Log OFF' on the right. At the bottom, there are two buttons: 'PROGRAM' and 'MANUAL'.

**Drying Accessory Sensor Table** – The middle section of the screen displays a list of all the sensors that are available for the connected Drying Accessory. Sensors that are disconnected will have three dashes (---) for their value.

**Drying Accessory Status Box** – The status box is located directly below the sensor table. The text on the left side will indicate the current operation mode of the Drying Accessory (OFF, Manual, or Program). When in Manual mode, the word “Manual” and the current Shelf Temp Set Point value will be displayed in this location. If a program is running the program name, Step #, and Time Remaining (TR) in the current Step will be displayed in this location. The right side of the status box will indicate if Data Logging is currently ON or OFF.

- **PROGRAM** – Pressing this button will take you to the Programs screen, where you can create a new program, or start, edit, view, copy or delete a saved program.
- **MANUAL** – Use this button to enter a Shelf Temp Set Point and/or start the Drying Accessory in manual mode.

## Manual Mode

Manual mode can be used to control the shelf temperature to a single set point value between  $-20^{\circ}\text{C}$  and  $+60^{\circ}\text{C}$ .

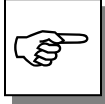

THE SHELVES HAVE NO COOLING MECHANISM, THEREFORE ANY COOLING BELOW ROOM TEMPERATURE IS DONE BY THE FROZEN SAMPLES AND THE COOLING FROM THE SUBLIMATION PROCESS THAT IS OCCURRING.

**Primary Drying Phase** - Allow the vacuum to pull down to the desired value. Start the Bulk Tray Dryer in MANUAL mode. At no time during the primary drying phase should the product temperature be allowed to rise above the eutectic temperature. The set point temperature should be lower than the eutectic temperature of the sample. If the eutectic temperature is below  $-20^{\circ}\text{C}$ , do not set the heater temperature for primary drying and do not start the Bulk Tray Dryer (in Manual or Program mode).

**Secondary Drying Phase** - After all the free moisture is removed in the primary drying phase, the temperature may be increased for the secondary drying phase.

## Starting MANUAL Mode

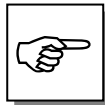

BEFORE STARTING THE TRAY DRYER, ENSURE THAT THE COLLECTOR IS “ON” AND HAS COOLED TO  $-40^{\circ}\text{C}$  OR BELOW.

1. Turn the Bulk Tray Dryer power switch ON. The POWER / STANDBY LED Indicator will turn ON.
2. On the Freeze Dryer display, go to the Drying Accessory screen
3. Press the “MANUAL” button
4. Enter a Set Point value between  $-20^{\circ}\text{C}$  &  $+60^{\circ}\text{C}$ , then press “Start”.
5. The IN PROCESS LED Indicator will turn ON.

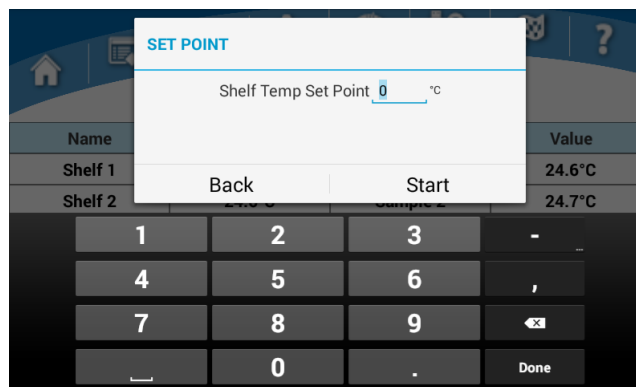

## Chapter 4: Using Your Bulk Tray Dryer

### Changing the Shelf Temp Set Point Value

If the Tray Dryer is already running in MANUAL mode and you want to change the current Shelf Temp Set Point value:

1. Go to the Drying Accessory screen.
2. Press the “MANUAL” button.
3. Enter a new Set Point value and press “Apply”.

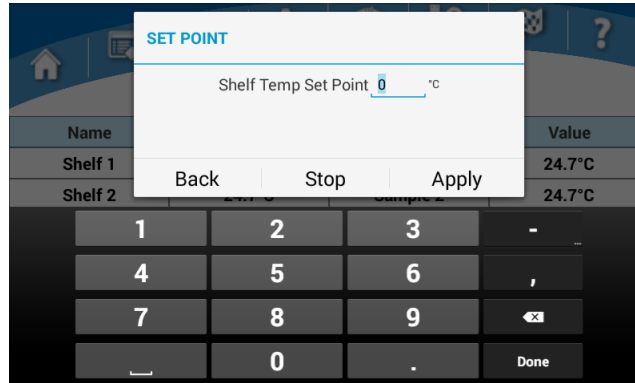

### Stopping MANUAL Mode

1. Go to the Drying Accessory screen
2. Press the “MANUAL” button
3. Press the “Stop” button
4. The IN PROCESS LED Indicator will turn OFF.
5. Turn OFF the vacuum pump.
6. Position the “Vac Release” valve to OPEN.
7. Allow the vacuum to bleed to atmospheric pressure, then open the door and remove the samples.
8. Turn OFF the Freeze Dryer collector, defrost the ice, drain the collector chamber and dry.

## Programs

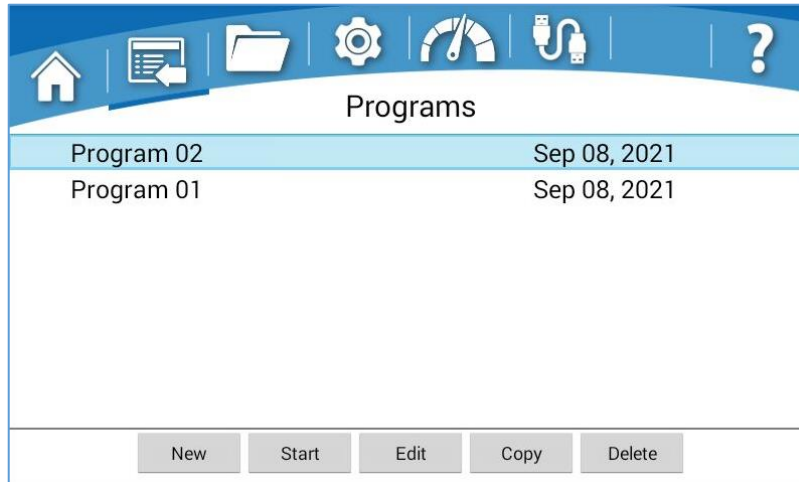

The Programs screen will allow you to create and store programs that are used to control the shelf temperature and vacuum level. Programs can be designed that take the product through both primary and secondary drying phases.

When no program has been selected the “New” button will be the only active button along the bottom of the screen. A program can be selected from the program list by pressing the program name. When a program has been selected, the program row will be highlighted (blue). With a program selected, the rest of the buttons along the bottom of the screen will become active (Start, Edit/View, Copy & Delete).

- **New** – Use this button to add a new program to the program list. The new program name will be defaulted to a two-digit sequential number (starting with “Program 01”) that will be incremented as new programs are added to the list (i.e., Program 02, Program 03...). The default name can be edited as desired in the New or Edit screen.
- **Start/Stop** – Use this button to start or stop a program. The wording on this button will change from “Start” to “Stop” depending on whether a program is currently running.

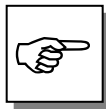

THE TRAY DRYER MUST BE ATTACHED TO THE FREEZE DRYER (VIA THE COMMUNICATION CABLE) TO RUN A PROGRAM. IF IT IS NOT ATTACHED TO THE FREEZE DRYER, THE START BUTTON WILL BE INACTIVE.

- **Edit/View** – Use this button to Edit or View the parameters of a saved program (the wording on this button will change from “Edit” to “View” depending on whether the program is locked or unlocked for editing).
- **Copy** – Use this button to Copy a selected program. The default name will be “*Program Name\_copy*”. The program name can be edited as desired.
- **Delete** – Use this button to delete a saved program from the list.

## Chapter 4: Using Your Bulk Tray Dryer

When a program is currently in progress, a “running man” icon will appear to the left side of the program name. If the running program is selected (highlighted), the “Stop” button will be active, and the “Delete” button will be inactive.

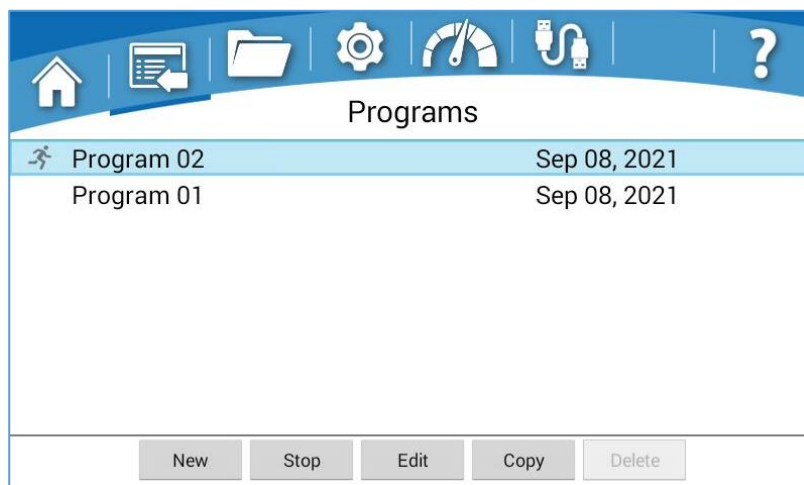

### Creating a New Program

When the “New” button is selected, the following screen will be displayed.

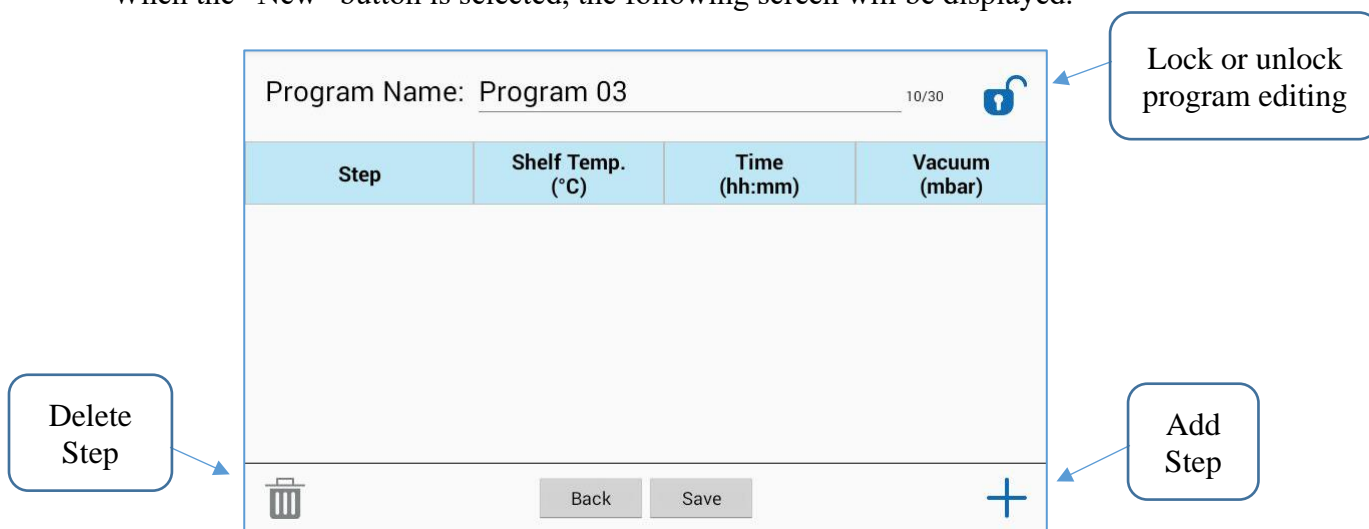

Pressing the program name field will allow you to edit the program name. The “Add” button will add a new Step to the program and take you through a series of screens to set the Shelf Temp., Time, and Vacuum. Values can be edited by pressing any of the cells. Pressing the “Delete” button will delete the selected step from the program. Changes will not be saved until the “Save” button is pressed. Pressing the “Back” button will return to the Programs screen without saving changes.

- **Shelf Temp.** - May be set anywhere from  $-20^{\circ}\text{C}$  to  $+60^{\circ}\text{C}$  in  $1^{\circ}\text{C}$  increments.

- **Time** – This time represents how long the system will hold at the Shelf Temp. that has been programmed for each Step. The time can be set from 00:01 to 99:59 (1 min to 99 hrs 59 min). It can also be set to an indefinite amount of time, which is represented by the infinity symbol ( $\infty$ ).
- **Vacuum** – Vacuum control can be set from 0.000 to 1.500 mbar.

## Starting a Program

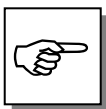

BEFORE STARTING A PROGRAM, ENSURE THAT THE COLLECTOR IS “ON” AND HAS COOLED TO -40°C OR BELOW.

1. Go to the Programs screen. You can access the Programs screen in two different ways, both lead to the same location.
  - a. Directly access the Programs screen by selecting the Programs icon from the main menu bar at the top of the display.
  - b. Go to the Drying Accessory screen, then select the PROGRAM button at the bottom of the screen.
2. Select a program from the saved programs list, or create a new program.
3. With the desired program selected from the list, press the START button.
4. The IN PROCESS LED Indicator will turn ON.

## Stopping a Program

1. At the end of the last programmed step, the Tray Dryer will turn OFF automatically. The IN PROCESS LED Indicator will turn OFF and a “Program Complete” alert will be displayed on the Freeze Dryer touch screen. The Freeze Dryer refrigeration (collector) and vacuum systems will continue to run until they are turned off by the user.
2. To stop the Tray Dryer before the completion of the last programmed step
  - Go to the Programs screen
  - Select (highlight) the program that is currently running
  - Press the STOP button
  - The IN PROCESS LED Indicator will turn OFF
3. Turn OFF the vacuum pump.
4. Position the “Vac Release” valve to OPEN.
5. Allow the vacuum to bleed to atmospheric pressure, then open the door and remove the samples.
6. Turn OFF the Freeze Dryer collector, defrost the ice, drain the collector chamber and dry.

## Freeze Drying Using the Manifold Valves

Some Bulk Tray Dryers are equipped with a 6-Port Manifold. The procedure below should be followed when freeze drying samples using the manifold.

1. Close and latch the Bulk Tray Dryer door.
2. Set the Vac Release valve to CLOSE.
3. Pre-freeze samples - Shell freezing of samples is recommended.  
Appropriate containers for freeze drying includes ampoules, serum bottles, and wide mouth freeze drying flasks. Proper sample container size should always be at least two to three times the sample size (i.e., 150 ml samples should be prepared in 300 ml containers or larger).
4. Start the Freeze Dryer in either the Auto or Manual mode (See the Freeze Dryer User's Manual)
5. Connect a pre-frozen sample to a valve on the manifold using an adapter. Some vials can be attached directly to the sample valve. Turn the plastic valve knob to the "VACUUM" position to open the valve, which connects the attached sample to system vacuum. The bevel on the knob should be positioned toward the sample port.

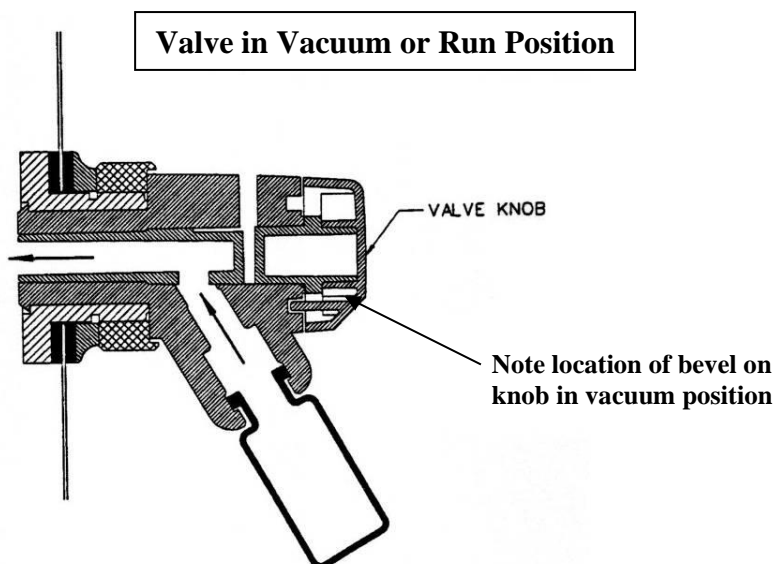

6. Before adding another sample, allow system vacuum to return to 0.133 mbar or lower. Any combination of valves and sample sizes may be utilized at one time provided that the system vacuum and collector temperature remain sufficiently low to prevent melting of the frozen sample.
7. When all the frost has disappeared from the outer surface of the sample container and no cold spots can be detected by handling the container, the sample is nearly dry. To be certain of low final moisture content, dry the sample for several hours past this point.

- To remove a container after drying is complete, turn the plastic knob on the valve to the “VENT” position, which closes the valve and vents the container. Should backfilling with an inert gas be required, simply connect the gas supply line to the vent port on the valve. The sample container may now be removed. In the vent position the bevel on the knob should point away from the sample port.

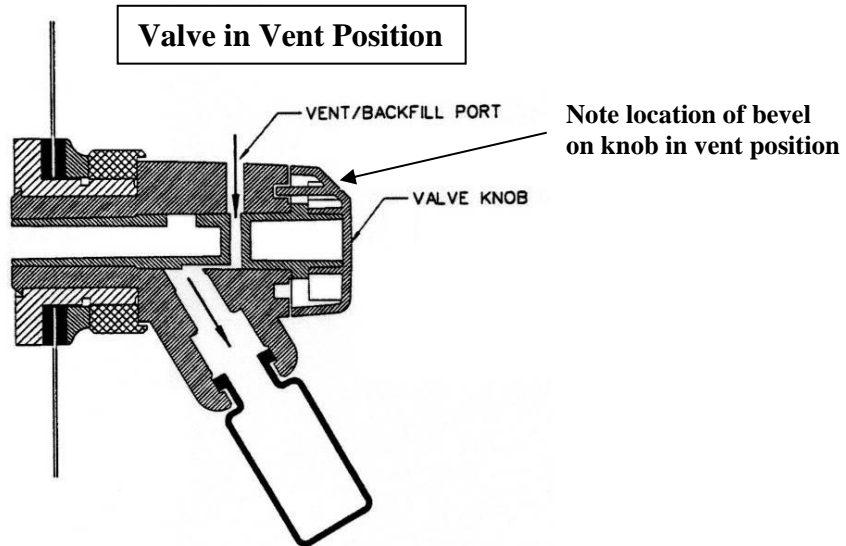

- Ampules may be flame sealed while connected to a valve by using a sealing torch. Care must be taken not to burn the valve. An insulation material placed between the valve and the torch is recommended.
- Shut off the Freeze Dryer, defrost the ice and drain the collector and dry. See the Freeze Dryer User's Manual.

## Alerts

A number of events may occur during a lyophilization procedure that will cause an alert to be displayed on the Freeze Dryer touch screen. An audible alarm (beeper) will also be sounded that will automatically be muted after one minute.

The specific alert type can be identified by observing the message box on the Freeze Dryer display. The alert message box and audible alarm can be dismissed by pressing the “Back” button on the alert message box. The following conditions will initiate an alert:

## Chapter 4: Using Your Bulk Tray Dryer

---

### **Power Fail**

If a power failure to the Bulk Tray Dryer occurs while a run is in progress, the “Power Fail – BT” alert will be displayed when power is restored. If the failure is of a short duration and the Freeze Dryer collector does not warm up above  $-30^{\circ}\text{C}$ , when power is restored the Freeze Dryer and Bulk Tray Dryer will restart and resume operation of the refrigeration and vacuum systems. If the power failure lasts for a longer duration and the collector warms above  $-30^{\circ}\text{C}$ , when the power is restored, the Freeze Dryer will not automatically restart. This prevents melted sample from being drawn into the collector and prevents liquid from being drawn into the vacuum pump.

### **Shelf Temp Variation**

Once the shelf temperature has stabilized (held set point temperature within  $\pm 3^{\circ}\text{C}$  for 20 minutes), if the shelf temperature varies more than  $\pm 3^{\circ}\text{C}$  from the set point, the “Shelf Temp Variation” alert will be displayed.

### **Shelf Temp Set Point**

If during a Ramp segment (when shelf temperature is transitioning to the next Shelf Temp Set Point) the shelf temperature stabilizes without reaching the Shelf Temp Set Point, the control will automatically enter the next Hold segment and the “System Temp Set Point” alert will be displayed.

### **Program Complete**

When the last step of a running program has been completed, the “Program Complete” alert message will be displayed.

---

## Chapter 5: Maintaining Your Bulk Tray Dryer

### Service Safety Precautions



- Always ensure that only authorized technicians service the equipment.
- If performing any electrical maintenance, always disconnect the power at the main disconnect.
- Always practice team lifting when moving heavy equipment.
- After servicing, verify that all access panels or covers are in place before resuming normal operation of the equipment.

### Routine Maintenance Schedule

Under normal operation, the Freeze Dryer requires little maintenance. The following maintenance schedule is recommended:

#### **As needed:**

1. The user has the responsibility for carrying out appropriate decontamination if hazardous material is spilled on or inside the equipment. This may be done by wiping the contaminated surfaces with a soft cloth dampened with alcohol. Alcohol may craze the acrylic door. Before using any cleaning or decontamination method except those recommended by Labconco, users should check with Labconco that the proposed method will not damage the equipment.
2. Clean up all spills; remove liquids from the chamber.
3. Clean door and gasket using soft cloth, sponge or chamois and a mild, non-abrasive soap or detergent.
4. Check oil level of the vacuum pump. It should be between MIN and MAX. If the oil level is less than an inch (25.4 mm) above MIN, add oil to proper level.
5. If oil shows cloudiness, particles or discoloration, drain the pump and replace with fresh oil.

## Chapter 5: Maintaining Your Bulk Tray Dryer

---

6. Utilization of acids requires immediate cleaning and neutralization after a run or physical damage will result.

### **Monthly:**

1. The rubber components on the Bulk Tray Dryer may eventually deteriorate and require replacement. The effective life of rubber parts depends upon both their usage and the surrounding environment. Check all rubber hoses and gaskets and replace any that show signs of hardening, permanent set or deterioration.
2. Using a soft cloth, sponge or chamois and a mild, non-abrasive soap or detergent, clean the acrylic door.
3. Using a soft cloth, sponge, or chamois and a mild, non-abrasive soap or detergent, clean the exterior surfaces of the unit. Liquid spray cleaners and polishes may be used on the exterior surfaces. Do not use solvents to remove stains from the exterior surfaces as they may damage the finish.

## **Decontamination**

When freeze drying biological substances, it may be necessary to decontaminate the system. A surface decontaminant should be used to clean the accessible surfaces. The use of ethylene oxide is not recommended because of its hazardous and corrosive nature. Contact Labconco for additional information.

---

## Chapter 6: Troubleshooting

Refer to the following if your Freeze Dryer fails to operate properly. If the suggested corrective actions do not solve your problem, contact Labconco for additional assistance.

FreeZone Freeze Dryers that are clean, dry and without samples attached should reach a vacuum of 0.133 mbar within 30 minutes and should achieve an ultimate vacuum of 0.040 mbar within 18 hours when the refrigeration is operating. If the Freeze Dryer does not obtain a satisfactory vacuum, perform the following maintenance tests.

### Vacuum Pump

First make sure that the vacuum pump operates. If it fails to operate, check the electrical connections of the Freeze Dryer to the power source and then check the electrical connection of the vacuum pump to the Freeze Dryer. If the vacuum pump has a power switch, make sure that it is turned on. If the vacuum is not adequate when the vacuum pump is operating, proceed with the following steps:

1. Check the oil and ensure it is clear and clean. If the oil looks cloudy or has any particulates, replace the pump oil. Sometimes it may be necessary to flush the pump with clean oil several times. To flush the pump, run the pump 5 to 10 minutes to allow the oil to warm up. Drain the oil and refill with clean oil. Repeat as necessary.
2. Check the oil level in the pump. Ensure it is filled to the correct level.
3. Check vacuum hose connections from the pump to the Freeze Dryer and try running the unit. If vacuum problems continue, consider obtaining a second vacuum gauge capable of reading a vacuum of 0.010 mbar. It is often useful in determining if the vacuum pump is operating properly and the vacuum sensor reading is accurate.

## Chapter 6: Troubleshooting

---

4. Isolate the pump by disconnecting the vacuum hose from the Freeze Dryer. Deadhead the pump by inserting the vacuum sensor from a secondary vacuum gauge into the end of the vacuum hose and observe the vacuum reading obtained. Confirm that the pump is capable of achieving an ultimate vacuum less than 0.010 mbar or approximately 10 microns. If an inadequate vacuum reading is obtained, the pump has most likely failed and may need to be replaced or rebuilt.

## Gaskets, Tubing, Connections, Sample Valves

1. Check all sample valves on the optional 6 port manifold (if installed) and ensure all valves are closed or in the vent position.
2. Check the drain line on the Freeze Dryer and ensure that the quick connect drain fitting is disconnected from the quick connect drain coupling.
3. Check all rubber vacuum tubing for signs of deterioration or cracking.
4. Check all connections and make sure they are secure and leak tight.
5. Check the Freeze Dryer collector lid gasket and the Bulk Tray Dryer door gasket for indentations, cracks or tears. Clean gaskets using a soft, lint free cloth or paper towel.
6. The Bulk Tray Dryer chamber and base unit collector chamber must be dry.
7. When checking the sample valves, (if the system is so equipped), pull as much vacuum as possible. If a vacuum indication is displayed, wiggle or rotate the valves and watch the gauge for any fluctuations. Fluctuations can indicate a potential vacuum leak. If the valve seems to be in good condition, remove the valve and apply a thin coat of vacuum grease to the stem and the outside sealing surface of the valve body, and reinstall the valve. If the valve still seems to be the source of the problem, remove the valve and stopper the hole with a rubber stopper (#6). Continue checking the other valves.

The illustration below shows how the sample valve installs on a manifold.

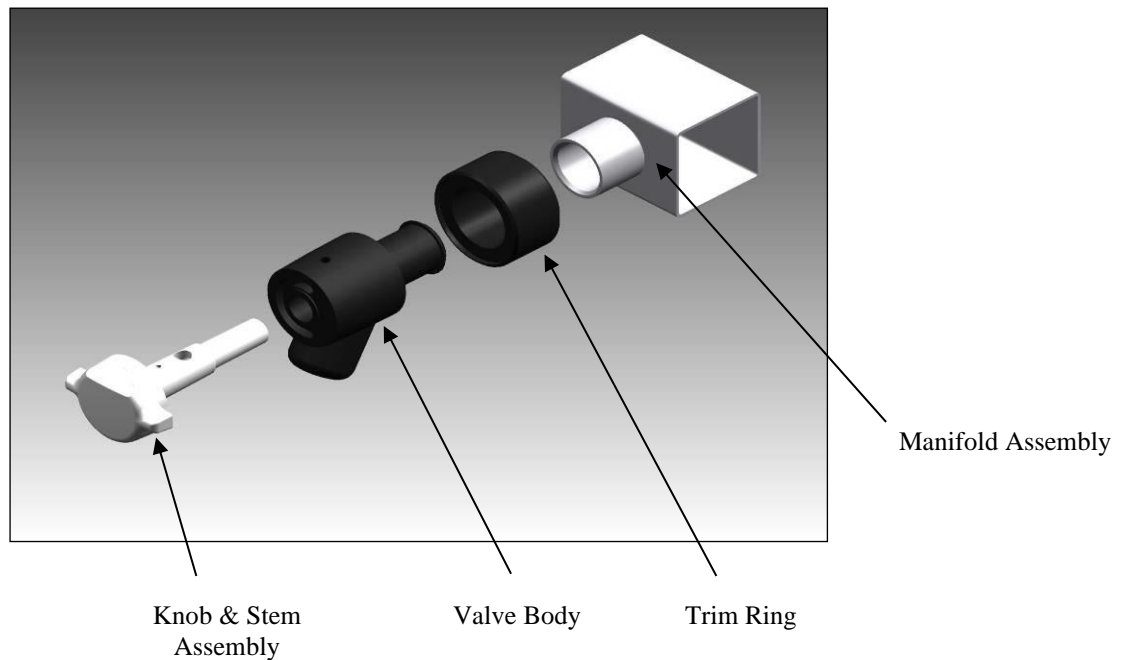

## System Components and Collector Chamber Isolation

The following test allows you to check the pump and the connections from the pump to the vacuum tube.

1. Insert a rubber stopper (#2) in the vacuum port in the left side of the collector chamber.
2. Restart the vacuum system and check your vacuum indication. Insufficient vacuum indicates a bad pump or a leak in the connections from the pump to the side of the chamber.
3. Remove #2 stopper after completing test.

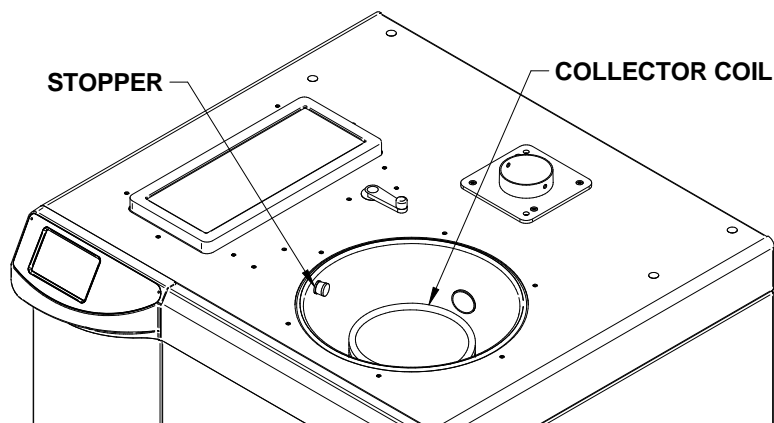

## Chapter 6: Troubleshooting

The next test will allow you to determine if the vacuum leak is in the Bulk Tray Dryer or in the Console Freeze Dryer.

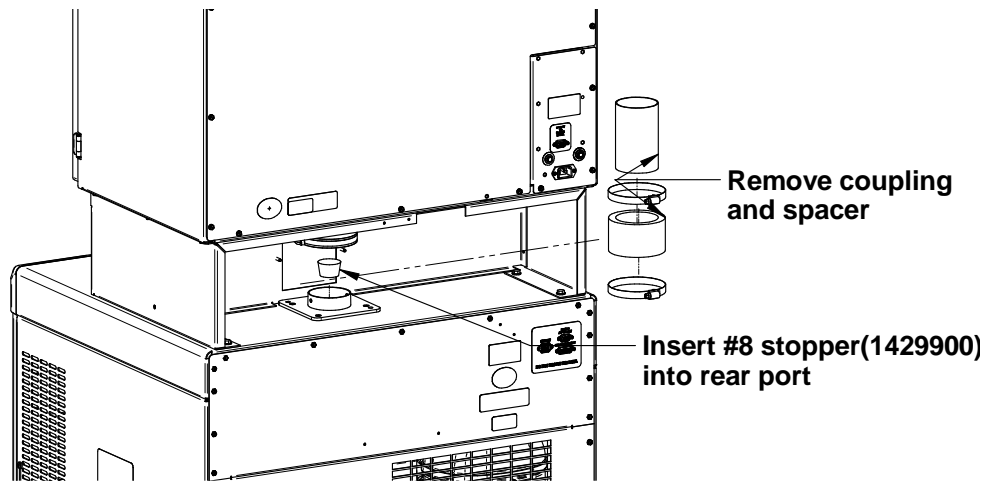

1. Remove the coupling and spacer connecting the Bulk Tray Dryer to the Freeze Dryer.
2. Insert a #8 stopper into the rear port.
3. Start the vacuum pump and observe the vacuum indication. If the vacuum indication is good, then the problem is in the Bulk Tray Dryer and you should proceed to Section IV. If the vacuum is insufficient then the leak is the Freeze Dryer. All easily accessible connection should be checked first for leaks. The figure below points out more difficult areas to check for leaks.

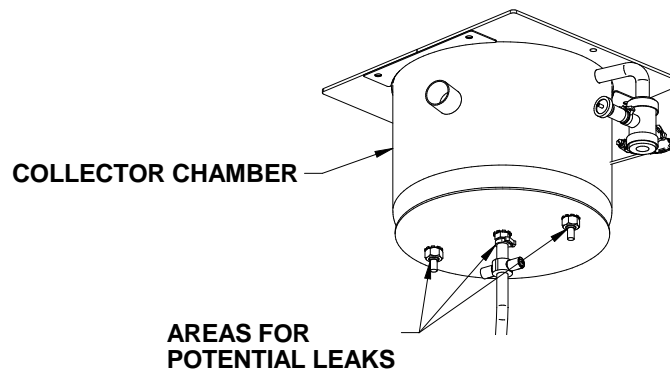

4. If a leak is observed around the bulkhead fittings (where the legs of the collector coil pass through the bottom of the collector chamber), access the bottom of the chamber and remove the insulation. Tighten the appropriate fitting by placing a wrench on the fitting inside the chamber and use a second wrench to turn the nut on the bottom of the chamber. Be careful not to damage the evaporator coils or the brazed joints to the refrigeration system. Once the fitting is tightened, perform the test again. If a leak is

still present at the bulkhead fittings, loosen the bulkhead fittings and apply vacuum grease to the O-rings, then reassemble and test.

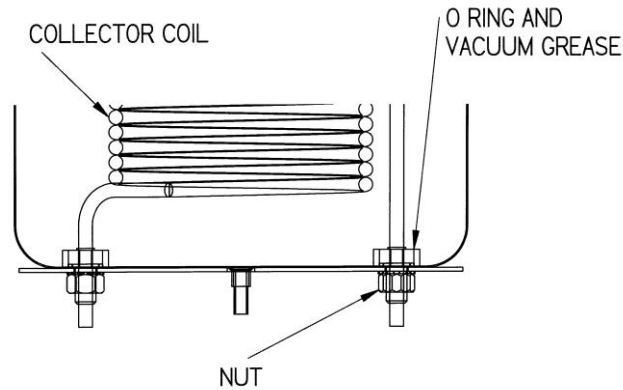

## Bulk Tray Dryer

- Inspect the door and door gasket.
- Inspect the coupling between the freeze dryer and the Bulk Tray Dryer.
- Remove the top left hand cover panel and inspect the valve and hose connections to the chamber.
- Inspect the electrical pass through and gasket on the left side of the chamber.

## Door Adjustment

The following adjustments can be made if the door is not sealing properly when vacuum is applied.

1. The latch can be adjusted to increase the force between the door gasket and chamber sealing surface.
  - a. Open the door.
  - b. Using two ½" wrenches, loosen the nuts securing the latch pawl.
  - c. Move the latch pawl towards the door to tighten the latch.
  - d. Tighten the nuts.

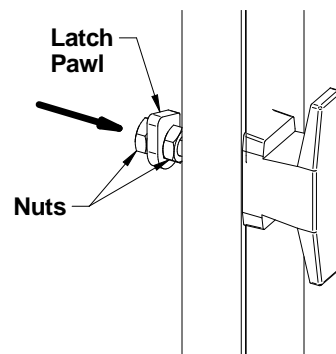

## Chapter 6: Troubleshooting

---

2. The door hinges can be adjusted to move the door in towards the chamber sealing surface.
  - a. Loosen the screws to the hinge covers and rotate the hinge cover out of the way.
  - b. Turn on the vacuum pump using the Freeze Dryer controls.
  - c. After the vacuum level reaches approximately 5 mbar, loosen the six screws on the door hinges. ***Do not remove the screws.***
  - d. Once the vacuum level reaches approximately 1 mbar, tighten the six screws.

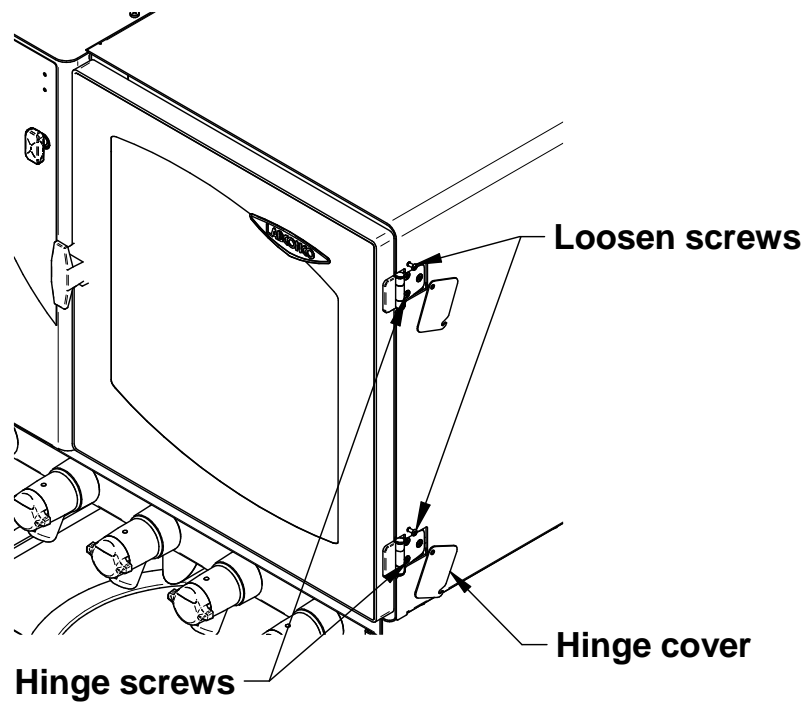

## Appendix A: Components

The following pages list components that are available for your Bulk Tray Dryer. The parts shown are the most common replacement parts. If other parts are required, contact Product Service.

Item	Qty	Part No.	Description
1	1	1302301	Switch
2	1	7317000	Printed Circuit Board
3	1	7361900	Pass through
4	1	7344300	Gasket – Pass through
5	2	7684200	Coupling
6	4	1966900	Clamp
7	1	7367700	Door Assembly
8	1	7351700	Gasket – Door
9	3	7365800	Temperature Sensor (Sample)
10	3	730151000	Heated Shelf Assembly (115V) - for Bulk Tray Dryers with serial tag revision A, B, C, & D
		730151010	Heated Shelf Assembly (230V) - for Bulk Tray Dryers with serial tag revision A, B, C, & D
		730151020	Heated Shelf Assembly (115V) - for Bulk Tray Dryers with serial tag revision E or higher
		730151030	Heated Shelf Assembly (230V) - for Bulk Tray Dryers with serial tag revision E or higher
11	1	7364601	Communication Cable
12	1	1345700	Power Cord 230V 50Hz India
		1332600	Power Cord 230V 50Hz UK
		1332700	Power Cord 230V 50Hz China
		1336100	Power Cord 230V 50Hz EU
		1338000	Power Cord 230V 60Hz US
		1334500	Power Cord 115V 60Hz US
13	1	7356200	Ground Strap

## Appendix A: Components

---

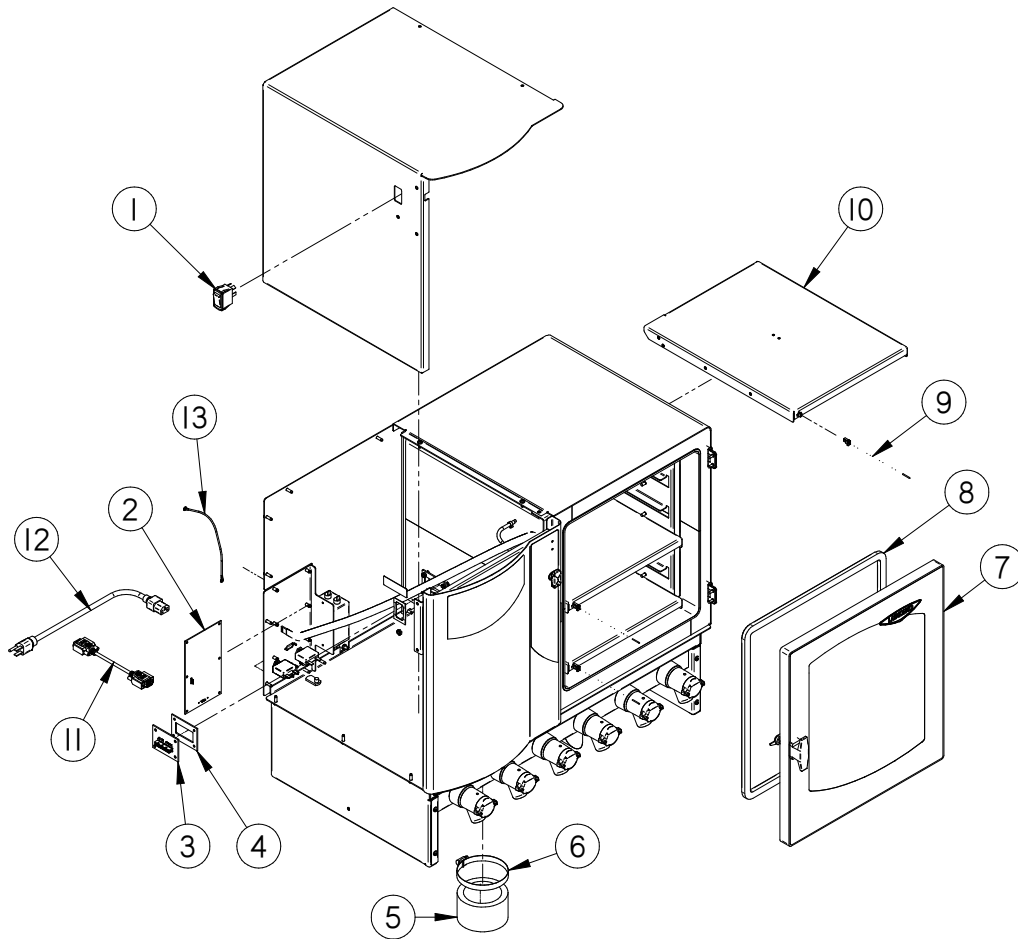

---

# Appendix B: Dimensions

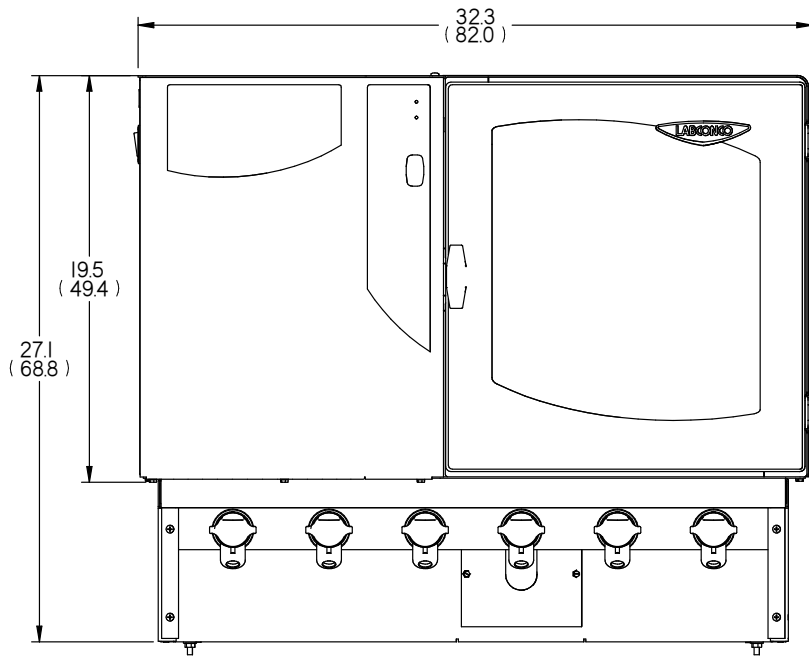
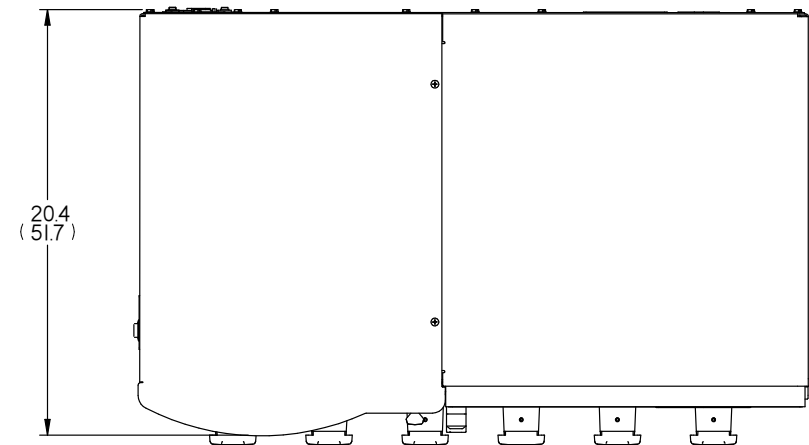

SHOWN WITH 6 PORT MANIFOLD  
INCHES  
(CENTIMETERS)

## Appendix B: Dimensions

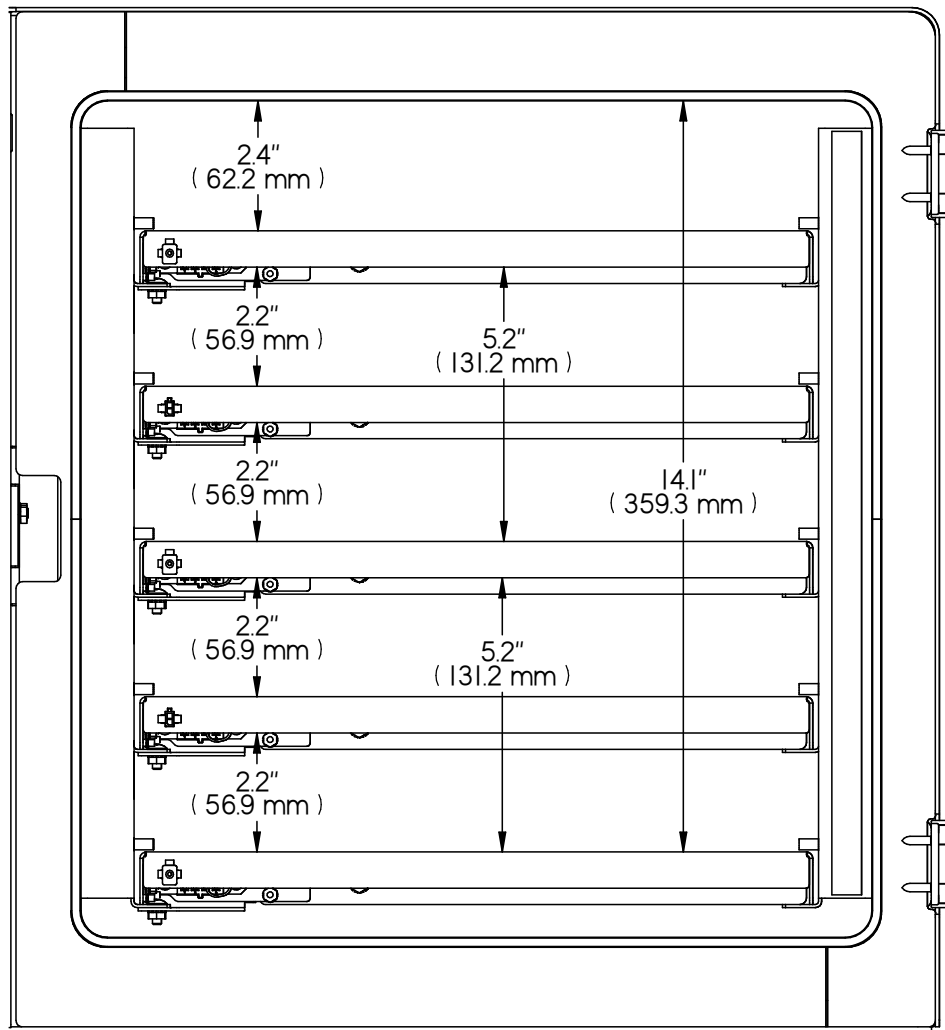

## Appendix C: Specifications

This Appendix contains technical information about the Freeze Dryer including electrical specifications and environmental operating conditions.

### Electrical Specifications

Catalog #	Description	Voltage		Frequency (Hz)	Current Rating Amps
		Nominal	Operating Range		
780601*00	Bulk Tray Dryer	115V	103 - 127	50/60	8
780601*10 780601*15 780601*30 780601*40 780601*50 780601*70	Bulk Tray Dryer	230V	207 - 253	50/60	4

(\* represents 0, 1, 2 or 3 depending on optional factory installed features)

### Environmental Conditions

- Indoor use only.
- Ambient temperature range: 41° to 104°F (5° to 40°C).
- Maximum relative humidity: 80% for temperatures up to 88°F (31°C), decreasing linearly to 50% relative humidity at 104°F (40°C).
- Main supply voltage fluctuations not to exceed  $\pm 10\%$  of the nominal voltage.
- Transient over voltages according to Installation Categories II (Over voltage Categories per IEC 1010). Temporary voltage spikes on the AC input line that may be as high as 1500V for 115V models and 2500V for 230V models are allowed.
- Used in an environment of Pollution degrees 2 (i.e., where normally only non-conductive atmospheres are present). Occasionally, however, a temporary conductivity caused by condensation must be expected, in accordance with IEC 664.

---

## **Appendix D: Accessories**

For a complete list of accessories offered for the Bulk Tray Dryer please consult our website at [www.labconco.com](http://www.labconco.com).