



Please read user's manual  
before operating equipment

Original Instructions

## LABCONCO CORPORATION

8811 Prospect Avenue

Kansas City, MO 64132

(800) 821-5525 | +1 (816) 333-8811

# User's Manual

## FlaskScrubber® Vantage Series® Glassware Washer



Register this product

# FlaskScrubber Vantage Series® Glassware Washers

2021—Present

422101010    422101013

Copyright © 2020 Labconco Corporation. The information contained in this manual and the accompanying products are copyrighted and all rights reserved by Labconco Corporation. Labconco Corporation reserves the right to make periodic design changes without obligation to notify any person or entity of such change.

## Warranty

Labconco Corporation provides a warranty to the original buyer for the repair or replacement of parts and reasonable labor as a result of normal and proper use of the equipment with compatible chemicals. Broken glassware and maintenance items, such as filters, gaskets, light bulbs, finishes and lubrication are not warranted. Excluded from warranty are products with improper installation, erratic electrical or utility supply, unauthorized repair, use with incompatible chemicals, or non-factory modifications to the original product.

SteamScrubber, FlaskScrubber and FlaskScrubber Vantage Series Glassware Washers carry a two-year warranty from date of installation or three years from date of shipment from Labconco, whichever is sooner. Warranty is non-transferable and only applies to the owner (organization) of record.

Buyer is exclusively responsible for the set-up, installation, verification, decontamination or calibration of equipment. This limited warranty covers parts and labor, but not transportation and insurance charges. If the failure is determined to be covered under this warranty, the dealer or Labconco Corporation will authorize repair or replacement of all defective parts to restore the unit to operation. Repairs may be completed by 3<sup>rd</sup> party service agents approved by Labconco Corporation. Labconco Corporation reserves the rights to limit this warranty based on a service agent's travel, working hours, the site's entry restrictions and unobstructed access to serviceable components of the product.

Under no circumstances shall Labconco Corporation be liable for indirect, consequential, or special damages of any kind. This warranty is exclusive and in lieu of all other warranties whether oral, or implied.

## Returned or Damaged Goods

Do not return goods without the prior authorization from Labconco. Unauthorized returns will not be accepted. If your shipment was damaged in transit, you must file a claim directly with the freight carrier. Labconco Corporation and its dealers are not responsible for shipping damages.

The United States Interstate Commerce Commission rules require that claims be filed with the delivery carrier within **fifteen (15) days** of delivery.

## Limitation of Liability

The disposal and/or emission of substances used in connection with this equipment may be governed by various federal, state, or local regulations. All users of this equipment are required to become familiar with any regulations that apply in the user's area concerning the dumping of waste materials in or upon water, land, or air and to comply with such regulations. Labconco Corporation is held harmless with respect to user's compliance with such regulations.

### For additional questions or support:

**Labconco Customer Care** +1 (816) 333-8811

**Labconco Technical Support** (800) 821-5525

**Hours** 7:30 a.m.-5:30 p.m. CST

**Part #4676900 Rev. S**

**ECO 15508**

# Table of Contents

---

<b>1: INTRODUCTION</b>	<b>10</b>
About This Manual	10
Contents Included	10
<b>2: BEFORE YOU INSTALL</b>	<b>11</b>
Location Requirements	11
Clearance Requirements	11
Electrical Requirements	11
Hot Water Requirements	12
Purified Water Requirements	13
Cold Water Requirements	14
Drain Requirements	14
<b>3: SAFETY PRECAUTIONS</b>	<b>15</b>
Typographical Conventions	15
General Safety Precautions	17
Safety Precautions for this Product	19
<b>4: INSTALLATION</b>	<b>22</b>
Unpacking	22
Remove Racks	23
Check Shipment	24
Remove the shipping skid	24

Install the Leveling Feet	24
<b>Hot Water Connection</b>	<b>25</b>
<b>Pure Water Connection</b>	<b>26</b>
<b>Drain Connection</b>	<b>27</b>
<b>Electrical Connection</b>	<b>29</b>
<b>Ethernet Connection</b>	<b>32</b>
<b>Install the Washer</b>	<b>32</b>
Leveling the Washer	32
Securing the Washer to the Countertop	33
<b>Testing Your Washer</b>	<b>34</b>
Running Diagnostics	34
Verification	34
High Elevation Installations	35
<b>5: PERFORMANCE FEATURES</b>	<b>36</b>
<b>6: CLEANWORKS™ OPERATING SYSTEM</b>	<b>37</b>
<b>Control Panel</b>	<b>37</b>
Touch Screen Display	37
Open Button	37
On / Standby LED Indicator	37
Initial Power Up	38
<b>Home Screen</b>	<b>38</b>
Menu Tabs	38
Screen Indicator Bar	39
Program Selection	39
Printer (Accessory)	39
Start Program	40

Program Progress	40
Skip Segment	41
Pause	41
Cancel	41
Chart	41
<b>Program Screen</b>	<b>42</b>
View a Program	43
Edit a Program	44
Create a new program	45
Copy and Edit a Program	46
Delete a Program	46
Sorting Programs	46
<b>Log Data</b>	<b>47</b>
View Data File	48
Chart Data File	49
Export Data File	50
Delete Data File	50
<b>Settings</b>	<b>51</b>
Language	51
Security	52
Calibration - Offsets	53
Calibration - Setpoints	54
Time & Date	55
Alerts	56
Display	58
Units	59
Maintenance	60
Network	61
Customize	62

Data Logs	64
<b>Sensors</b>	<b>64</b>
<b>Accessories</b>	<b>65</b>
<b>Help</b>	<b>66</b>
About	67
Software Update via USB Thumbdrive	68
Software Update via the Ethernet	68
Automatic Update Notification	68
Diagnostics	69
Resources	70
Backup and Restore	71
Notification	72

## **7: USING YOUR GLASSWARE WASHER** **73**

<b>Washer Rack Configuration</b>	<b>73</b>
<b>FlaskScrubber Vantage Series Spindle Rack</b>	<b>73</b>
<b>Loading Glassware into the Spindle Rack</b>	<b>74</b>
Loading a Glassware Holder	75
<b>Removing or Adjusting the Optional Upper Rack</b>	<b>75</b>
Remove the upper rack	75
Replace the upper rack	75
Raise the upper rack height	76
Lower the upper rack height	76
<b>Liquid Detergent and Neutralizing Acid Rinse Dispense Systems</b>	<b>77</b>
To fill or purge the auto dispense systems	77
<b>Detergent Dispenser (Soap Cup)</b>	<b>78</b>
Adding Detergent	78
Adding Neutralizing Acid	79

Safety Reminders	80
Selecting and Starting a Wash Cycle	81
Interrupting a Wash Cycle/Open Door	82
Alarms	83
Completing the Wash Cycle	84

## **8: MAINTAINING YOUR GLASSWARE WASHER 85**

Maintenance Safety Precautions	85
Maintaining the Stainless Steel Interior	85
Clean Washer Cycle	86
Maintaining the Air Gap in Drain	86
Maintaining the Water Fill Valve	86
Cleaning the Sump Filter Screen	87
Replacing the HEPA Filter (PN4597300)	89
Maintaining the Conductivity Sensor	90
Cleaning the Conductivity Sensor	90
Recommended Maintenance Schedule	91

## **9: ACCESSORIES & CONSUMABLES 92**

Rack Inserts for Labware	92
Racks	93
Rack Accessories	94
Heater Cover Kit	94
Cool Drain Water Kit	94
Base Stand	95
Printer Cable Kit	95

RO Storage Tank	95
ScrubberMate Cart	96
Consumables	96
RO Connection Kit	96
<b>10: TROUBLESHOOTING</b>	<b>97</b>
<b>APPENDIX A: PARTS LIST</b>	<b>104</b>
<b>APPENDIX B: DIMENSIONS</b>	<b>105</b>
FlaskScrubber Vantage Series Exterior Dimensions	105
FlaskScrubber Vantage Series Interior Dimensions	105
<b>APPENDIX C: SPECIFICATIONS</b>	<b>106</b>
Programs	106
Power Data	108
Fill and Heat Specifications	108
Environmental Conditions	109

# 1: Introduction

---

Congratulations on the purchase of a Labconco Laboratory Glassware Washer. The glassware washer is designed and manufactured to thoroughly clean your laboratory glassware. The washer offers many unique features. To take full advantage of them, please acquaint yourself with this manual and keep it handy for future reference.

## About This Manual

This manual is written for the installer and user of this product. For detailed service, certification, or technical information, please utilize the Technical Manual found at [labconco.com](http://labconco.com).



This manual contains important operation and safety information. When you see a symbol, such as the INFO symbol to the left, pay close attention to the information provided. Before installing or operating this product, you must read [Section 3: Safety Precautions](#).

## Contents Included

The following items are included with all FlaskScrubber Vantage Series Washers:

- Lower Spindle Rack w/glassware holders
- Small spindle accessory kit
- User's manual USB thumb drive
- Quick Installation Guide with Door Unlock Pin
- Leveling Feet (6)
- GHT to NPT adapter (2)
- Anchoring Screws (2)
- Hose Clamp (1)
- Kick Panel Extension (2)
- #10-24 x 3/4" Hex Head Screw (3)

The location of these items and additional details are found in [Section 4: Installation](#).

## 2: Before You Install

---

Before you install the product, the installation site should be planned. Examine the location where you intend to install it. You must be certain that the area is level and of solid construction. In addition, a hot water source, a drain, a purified water source (if applicable), and an electrical supply must be located near the installation site. A cold water supply is required when the optional Cool Drain Water Kit is installed.

### Location Requirements

The Glassware washer should be located in an area that is in close proximity to the required utilities.

### Clearance Requirements

If your glassware washer is to be mounted undercounter model, you must ensure the undercounter opening is the proper size to accommodate the washer. The location should provide adequate clearance for the door to lay down with access to load and unload the racks.

See [Appendix B: Dimensions](#) for overall product dimensions.

### Electrical Requirements

The product models have the following electrical requirements.

Catalog Number	Heater Watts	Typical Operating Current (Amps)	Electrical Circuit Requirements <sup>1</sup>	
422101010	2.0kW	11 A	208-230 V, 50/60 Hz, 20 A	1
422101013	6.0kW	21/19/9 A <sup>2</sup>	208/230/400V,50/60Hz, 30/30/13A	3

<sup>1</sup> Electrical Requirements, 'V' = VAC (Voltage with alternating current), 'A' = Amperes

<sup>2</sup> Operating with 208V, current draw approximately 21 A; Operating with 230V, current drawing approximately 19 A. Operating with 400V, current drawing approximately 9 A.

It is recommended that FlaskScrubber Vantage Series Glassware Washers be hard-wired directly into a junction box. A 20 Amp dedicated circuit breaker or fuse is required for models rated at 208-230V (50/60 Hz) 2.0kW single phase. The 230V (50/60Hz) 6.0kw 3-phase models require a 30 amp 3-phase circuit breaker or fuse. The 400V(50Hz) 6.0kw 3-phase model requires a 13 amp 3-phase circuit breaker or fuse.

The 2.0kW models are designed to operate at 230 VAC, single phase, but will operate safely at nominal 208 VAC. The heater output will be reduced proportionally at 208VAC.

If your unit came with a factory installed power cord, the 230V 2.0kW rated models are supplied with a NEMA 6-20P power cord and require a dedicated 230V 20 Amp outlet. The 230V 6.0kW models are supplied with a NEMA 15-30P 3-Phase power cord and require a dedicated 30 amp outlet. The outlet must match the supplied NEMA plug. For models supplied with a power cord a power disconnect must be readily accessible near the unit. This can be accomplished either by unplugging it or by a switch.

 A dedicated outlet with an appropriate circuit breaker should be located as close as possible to the product, but no greater than 10 feet (3 m). Consult your local electrical codes for properly rated circuit breakers. For safe operation the dedicated outlet must provide a protective earthing ground connection to the product.

 Labconco does NOT recommend connecting the product's power cord into a GFCI outlet. GFCI outlets can nuisance trip, resulting in complete removal of power to the product.

## Hot Water Requirements

An existing hot water supply may be used as the hot water source for your glassware washer. Labconco recommends the inlet water temperature to be greater than 120°F (49°C) to fully activate powdered detergents and raise the glassware temperature to achieve fast and complete drying. In addition to shortening the cycle times, hotter water will typically produce better washing results. Refer to heating rates in Appendix C: Specifications to determine the heat up cycle time for a specific programs temperature set point at a specific inlet water temperature.

Water pressure must be between 20-120 psi (138-827 kPa) at the washer and provide a minimum of 0.7 gallons (2.6 liters) per minute flow rate at the specified pressure.

A customer supplied shut-off valve should be installed in the water supply line plumbed to the washer. The hot water inlet valve on the glassware washer is equipped with a male ¾-1½ Garden Hose Thread (GHT) hose fitting. If needed, a male ¾ National

Pipe Thread (NPT) hose fitting can be connected utilizing the GHT to NPT adapter provided with the washer. The supply hose from the shut off valve to the washer inlet valve is to be supplied by the customer. On undercounter installations, a minimum extra 3' of service loop is recommended for the supply hose to allow the washer to be slid in or out of its operating position.

An optional 6' long hose (Labconco Catalog Number 4544600) with  $\frac{3}{4}$ -11 $\frac{1}{2}$  GHT straight fitting on one end and  $\frac{3}{4}$ -11 $\frac{1}{2}$  GHT elbow on the other side is available from Labconco.

***The maximum temperature must not exceed 199°F (93°C).***

## Purified Water Requirements

To use purified water for the rinse cycle(s), a purified water supply is required. The washer can be connected to an in-house, pressurized, purified water supply, a water purification system, or a non-pressurized purified water container. At least 3.4 gallons (13 liters) of purified water must be available for each pure rinse. On pressurized systems, a customer supplied shut-off valve should be installed in the water supply line going to the washer. The purified water supply hose should be of sufficient size to permit at least 0.7 gallons (2.6 liters) per minute of flow. The pure water inlet valve on the glassware washer is equipped with a male  $\frac{3}{4}$ -11 $\frac{1}{2}$  GHT hose fitting. If needed, a male  $\frac{3}{4}$  National Pipe Thread (NPT) hose fitting can be connected utilizing the GHT to NPT adapter provided with the washer. The customer must supply the supply hose from the shut off valve to the washer inlet valve. It is recommended to have an extra 3' service loop in the supply hose to allow the washer to be slid in or out of its operating position.

On under counter installations an extra 3' service loop is recommended for the supply hose, this allows the washer to be slid in or out of its operating position.

The purified water system connections must be airtight to prevent the washer pump from pulling air instead of water.

If the purified water is stored in a carboy, at least 3.4 gallons (13 liters) must be available for each rinse. If all the purified water is not available at the start of a wash cycle, but instead is produced concurrently with the wash cycle, the production rate must permit at least 0.7 gallon (2.6 liters) per minute to be delivered to the washer.

***The maximum temperature must not exceed 199°F (93°C).***

## Cold Water Requirements

If the Cold Water Drain Kit (Labconco Catalog Number 4678401) is installed, an existing cold water supply may be used to mix with the hot drain water. It is recommended that the cold water temperature is colder than 54°F (12°C). Warmer water temperature will cause the drain temperature to be higher. The cold water supply must be capable of a flow rate of 3.5 GPM (13.2 LPM) and a pressure of 20-120 PSI (138-827 kPa).

A customer supplied shut-off valve should be installed in the water supply line plumbed to the washer. The cold water drain valve on the glassware washer is equipped with a female 3/8" compression fitting. The supply hose from the shut off valve to the washer cold water drain valve is to be supplied by the customer. Refer to the installation instructions supplied with the Cold Water Drain Kit, which is also available on the User's Manual Thumb Drive, for more information.

***The maximum temperature must not exceed 199°F (93°C).***

## Drain Requirements

The drain hose, with a 0.57" (1.45 cm) ID is installed during manufacture. The drain hose provides a flexible coupling to the building drain piping and can be secured with a spring or band hose clamp. A band hose clamp is provided with the washer.

Tubing or pipe, 5/8" (1.6 cm) ID or larger, should be provided for the building drain. The use of an air gap is strongly recommended to prevent siphoning of wastewater into the washer.

Do not reduce the size of the drain plumbing.

Glassware Washers that have been converted to Mobile models drain into a sink through a hose assembly that attaches to the faucet.

## 3: Safety Precautions

---

Before unpacking, installing, operating, maintaining, or servicing this equipment, read the following safety warnings and precautions.

Avant le déballage, l'installation, le fonctionnement, l'entretien ou la maintenance de cet équipement, lire les avertissements de sécurité et les précautions d'emploi.



**CAUTION** – See Manual. When this symbol is on the equipment, it indicates a caution that is detailed in this manual.

**MISE EN GARDE** – Voir le manuel. Lorsque ce symbole est apposé sur l'équipement, il renvoie à une mise en garde détaillée dans ce manuel.

### Typographical Conventions



**DANGER** – An imminently hazardous situation which, if not avoided, will result in death or serious injury.

**DANGER** – Situation dangereuse imminente qui, si elle n'est pas évitée, peut entraîner la mort ou des blessures graves.



**CAUTION** – Indicates a potentially hazardous situation which, if not avoided, may result in minor or moderate injury or damage to property.

**MISE EN GARDE** – Signale une situation potentiellement dangereuse qui, si elle n'est pas évitée, peut provoquer des blessures mineures à modérées ou des dommages matériels.



**NOTE** – Advice or suggestions to help the process.

**REMARQUE** – Conseils ou suggestions pour le déroulement du processus.



**BURN RISK (HIGH TEMPERATURE)** – Air or components that will be very hot. Take care not to touch these defined areas. Failure to avoid these areas may result in moderate to severe injury.

**RISQUE DE BRÛLURE (TEMPÉRATURE ÉLEVÉE)** – Air ambiant ou composant devenant très chaud. Veiller à ne pas toucher ces zones délimitées. L'absence de précaution pour éviter ces zones peut entraîner des blessures modérées, voire graves.



**EXTREME COLD (LOW TEMPERATURE)** – Air or components that will be very COLD. Take care not to touch these defined areas. Failure to avoid these areas may result in moderate to severe injury.

**FROID INTENSE (TEMPÉRATURE BASSE)** – Air ambiant ou composant devenant très froid. Veiller à ne pas toucher ces zones délimitées. L'absence de précaution pour éviter ces zones peut entraîner des blessures modérées voire graves.



**PINCH POINT** – Areas or components that can pinch or cut. Take care not to touch these defined areas.

**POINT DE PINCEMENT** – Zones ou composants présentant un risque de pincement ou de coupure. Veiller à ne pas toucher ces zones délimitées.



**MOVING PARTS** – Areas or components that contain moving parts. Take care not to touch these defined areas.

**PIÈCES MOBILES** – Zones ou composants contenant des pièces mobiles. Veiller à ne pas toucher ces zones délimitées.



**RISK OF ELECTRICAL SHOCK** – The specified procedure or area poses a risk of electrical shock. ALWAYS disconnect main power cord or electrical supply before proceeding.

**RISQUE DE CHOC ÉLECTRIQUE** – La procédure ou la zone spécifiée présente un risque de choc électrique. TOUJOURS débrancher le cordon d'alimentation secteur ou l'alimentation électrique avant toute intervention.



**FLAMMABLE / NO SOLVENTS** – Do not place flammable liquids or solvents in this product.

**INFLAMMABLE / PAS DE SOLVANTS** – Ne placez aucun liquid inflammable dans cette produit.



**LIFTING HAZARD** – Do not lift or move this equipment without assistance.  
**DANGER DE LEVAGE** – Ne pas soulever ou déplacer cet équipement sans assistance.



**MAGNETIC FIELD IN USE** – Magnets or magnetic field present.  
**CHAMP MAGNETIQUE UTILISE** – Présence d'aimants ou de champ magnétique.



**DO NOT TOUCH** – Components or areas indicated are sensitive and will suffer damage if touched. Take care not to touch these defined components or areas. Failure to avoid these areas will result in damage to the product.  
**NE PAS TOUCHER** – Les composants ou les zones indiquées sont sensibles et subiront des dégâts s'ils sont touchés. Veiller à ne pas toucher ces composants ou zones délimité(e)s. L'absence de précaution pour éviter ces zones endommagera le produit.



**TOOL REQUIRED** – Tool required to access specified area.  
**OUTIL NÉCESSAIRE** – Outil nécessaire pour accéder à la zone spécifiée.

## General Safety Precautions

Follow all the safety precautions described in this section.



Before removing any panels which require a tool for removal, **ALWAYS** disconnect the main power cord or electrical supply. Failure to remove all electrical power before proceeding will result in moderate to serious injury, death, or damage to property.

Avant le retrait d'un panneau nécessitant l'utilisation d'un outil, **TOUJOURS** débrancher le cordon d'alimentation secteur ou l'alimentation électrique. Le non-respect de la consigne consistant à couper complètement l'alimentation électrique avant toute intervention peut entraîner des blessures graves, la mort ou des dommages matériels.



Never contact moving parts with your person. Failure to avoid moving parts will result in moderate to serious injury, death, or damage to property.

Ne jamais toucher les parties mobiles. Le non-respect de la consigne consistant à éviter les pièces mobiles peut entraîner des blessures graves, la mort ou des dommages matériels.



Never misuse this product. Never disable, override, or otherwise bypass safety guards, panels, switches, sensors or alarms. Doing so will result in moderate to serious injury, death, or damage to this product or property.

Ne jamais utiliser ce produit à mauvais escient. Ne jamais désactiver, annuler ou contourner les capots, panneaux, interrupteurs, capteurs ou alarmes de sécurité. Ceci entraînerait des blessures graves, la mort ou des dommages matériels à ce produit ou à d'autres biens.



If the unit is not operated as specified in this manual it may impair the protection provided by the unit.

Si l'unité n'est pas utilisée comme spécifié dans ce manuel il peut diminuer la protection fournie par l'unité.



Do not position the unit so that it is difficult to operate the main disconnect device.

Ne placez pas l'appareil de sorte qu'il est difficile de faire fonctionner le dispositif principal de déconnexion.



Do not lift or move this equipment without assistance.

Ne pas soulever ou déplacer cet équipement sans assistance.

## Safety Precautions for this Product



Do not use any detachable power cord that is not adequately rated for the unit.  
Ne pas utiliser un fil électrique amovible qui n'est pas du tension nominale de l'appareil.



Do not damage internal wiring or other components while service panels are removed. If internal wiring or components are damaged, do not restore power, contact Labconco's Product Service Department immediately.

N'endommagez pas le câblage interne ou d'autres composants lorsque les panneaux de service sont retirés. Si le câblage interne ou les composants sont endommagés, ne rétablissez pas l'alimentation, contactez immédiatement le service après-vente des produits de Labconco.



Wear all required Personnel Protective Equipment (PPE) during service operations. At a minimum, this includes: eye protection, breathing protection, skin protection. Do not wear loose fitting clothes that can catch on internal surfaces.

N'endomm Portez tous les équipements de protection du personnel (EPI) requis pendant les opérations d'entretien. Au minimum, cela comprend: la protection des yeux, la protection respiratoire, la protection de la peau. Ne portez pas de vêtements amples qui pourraient s'accrocher aux surfaces internes.



After service, verify safe state of use before using the product. Contact Labconco's Product Service Department for questions on determining safe state of this product.

Après le service, vérifiez l'état de sécurité d'utilisation avant d'utiliser le produit. Contactez le service après-vente des produits de Labconco pour toute question relative à la détermination de l'état de sécurité de ce produit.



Verify protective earth ground continuity before using equipment.  
Vérifiez la continuité de la terre de protection avant d'utiliser l'équipement.



After service, verify safe state of use before using the product. Contact Labconco's Product Service Department for questions on determining safe state of this product.

Après le service, vérifiez l'état de sécurité d'utilisation avant d'utiliser le produit. Contactez le service après-vente des produits de Labconco pour toute question relative à la détermination de l'état de sécurité de ce produit



No hazards exist for: explosion, implosion, or release of toxic or flammable gases arising from the materials being heated.

Il n'existe aucun danger pour: explosion, implosion ou libération de gaz toxiques ou inflammables provenant des matériaux chauffés



Cleaning solutions that do not contain chlorine-based disinfectants (such as Bleach or hypochlorites) may be safely used on this equipment.

Les solutions de nettoyage qui ne contiennent pas de désinfectants à base de chlore (comme l'eau de Javel ou les hypochlorites) peuvent être utilisées en toute sécurité sur cet équipement.



If there is any doubt about the compatibility of decontamination or cleaning agents, contact Labconco's Product Service Department.

En cas de doute sur la compatibilité des agents de décontamination ou de nettoyage, contactez le service après-vente des produits de Labconco



To verify door safety interlock is functioning properly, close the washer door until it latches, start a program. Once the wash program has begun, try to pull the door open. Door should not open. Press the open button. The Pause Program? Pop-up should display on touch screen. Press yes. All functionality must stop. If the wash pump was running the door should unlock after 7 seconds. If this result is not achieved, do not use the product and contact Labconco's Product Service Department immediately.

Pour vérifier que le verrouillage de sécurité de la porte fonctionne correctement, fermez la porte de la laveuse jusqu'à ce qu'elle se verrouille, démarrez un programme. Une fois le programme de lavage commencé, essayez d'ouvrir la porte. La porte ne doit pas s'ouvrir. Appuyez sur le bouton d'ouverture. Le programme de pause? La fenêtre contextuelle devrait s'afficher sur l'écran tactile. Appuyez sur oui. Toutes les fonctionnalités doivent s'arrêter. Si la pompe de lavage fonctionnait, la porte devrait se déverrouiller après 7 secondes. Si ce

résultat n'est pas obtenu, n'utilisez pas le produit et contactez immédiatement le service après-vente de Labconco.



Steam and surfaces within this washer and its contents may become hot enough to cause burns.

La vapeur et les surfaces à l'intérieur de cette laveuse et son contenu peuvent devenir suffisamment chauds pour causer des brûlures.



Do not place any flammable liquids in this washer. Failure to empty and rinse glassware could result in fire or explosion.

Ne placez aucun liquide inflammable dans cette laveuse. Il y a un risque d'incendie ou d'explosion si la verrerie n'est pas vidée ni rincée.



LIFTING HAZARD – Do not lift or move this equipment without assistance.

DANGER DE LEVAGE –

Ne pas soulever ou déplacer cet équipement sans assistance.



The dedicated supply electrical circuit must be wired through an appropriately rated switch suitably located within 10 feet (3m) of the product and easily reachable. The switch must be marked as the disconnecting device for the product.

Le circuit électrique d'alimentation dédié doit être câblé via un interrupteur de calibre approprié situé à moins de 3 m (10 pieds) du produit et facilement accessible. L'interrupteur doit être marqué comme le dispositif de déconnexion du produit.



Use of Copper, Copper-Clad Aluminum, or Aluminum Conductors is allowed when hard-wiring this product. Verify the conductors used meet or exceed the requirements listed in [Section 2: Electrical Requirements](#) of this manual

## 4: Installation

---

With the installation site properly prepared, you are ready to unpack and install the equipment. This section covers how to:

- Unpack and move the equipment
- Connect hot water supply
- Connect the pure water supply
- Connect the drain
- Connect electrical service
- Connect to Local Area Network (LAN) via Ethernet
- Install the equipment
- 

### Unpacking

The following tools are required to unpack and install the equipment:



- Box knife
- 9/16" wrench
- Flat-blade screwdriver
- Phillips screwdriver
- 5/16" nut driver
- Carpenter level
- Fish Tape



The following safety precautions must be followed by all personnel unpacking the equipment.

- Wear safety glasses
- Wear gloves
- No loose fitting clothes
- Wear close-toed shoes
- The cartoning allows for lifting with a mechanical lift truck or hand truck. If you must lift the washer manually, use at least two (2) persons and follow safe lifting guidelines.



Carefully remove the outer carton and inspect the product for damage that may have occurred in transit. If the product is damaged, take pictures of the product and the outer packaging, and notify the freight carrier immediately. Retain the entire shipment, including outer packaging, intact for inspection by the carrier.



**Note:** United States Interstate Commerce Commission rules require that claims be filed with the freight carrier within fifteen (15) days of delivery.

Do not return goods without the prior authorization of Labconco. Unauthorized returns will not be accepted.

If the product was damaged in transit, you must file a claim directly with the freight carrier. Labconco Corporation and its dealers are not responsible for shipping damages.

Do not discard the carton or packing material for the product until all of the components have been checked, installed and tested.

Do not remove the washer from its shipping skid until it is ready to be placed into its final location. Move the washer by placing a flat, low dolly under the shipping skid.

### Remove Racks

- Locate the Door Unlock Pin taped to the Quick Installation Guide in the plastic bag which is taped to the top of the unit.
- Push the Pin into the hole in the control panel until the door opens. See Fig 4-1.

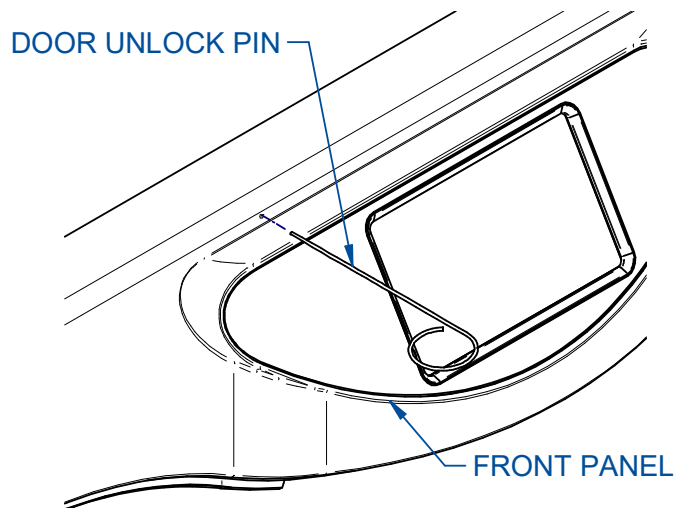

**Figure. 4-1**

- Remove accessories and other items from inside the washer. Cut tie wraps and remove racks.

- Retain the Door Unlock Pin for emergency access to the washer in case of power failure

### Check Shipment

- Determine the model of washer you received and verify that the components listed are present and undamaged (see [Section 1: Contents Included](#)). If you did not receive one or more of the components listed for your washer, or if any of the components are damaged, contact Labconco Corporation immediately for further instructions.
- After the washer components are verified, shut the door and move the washer near the installation site. Follow the steps listed below to remove the shipping skid from your washer. Retain the Door Unlock Pin for access into the washer in case of power failure.

### Remove the shipping skid

- Gently place the washer on its back, positioning the washer on the shipping carton or other cushioning material.
- Remove the six bolts fastening the skid to the washer.
- Retain the skid and fasteners until you test the various features of the washer.

### Install the Leveling Feet

**Figure 4-2**

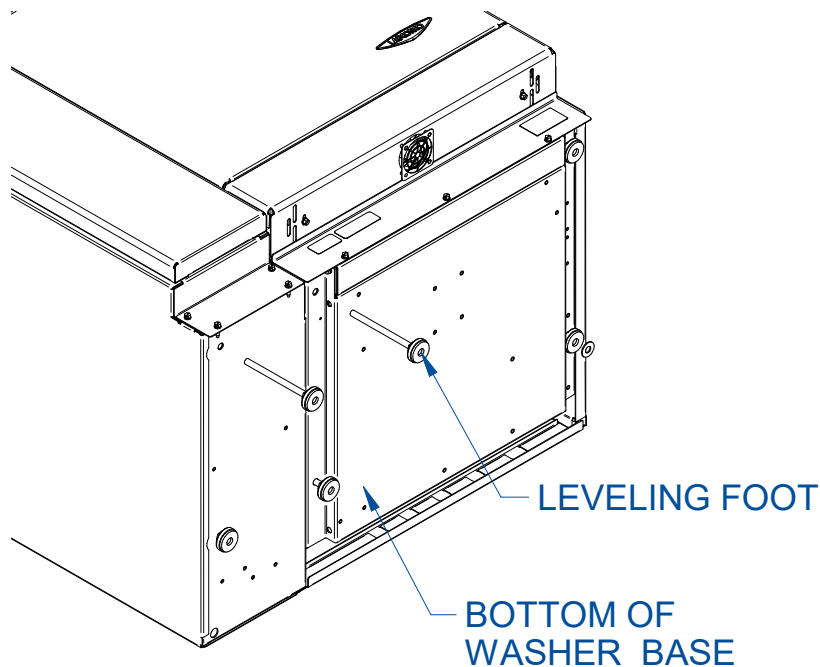

- Locate the holes on the bottom of the washer where the six skid-fastening bolts were previously attached. See Fig. 4-2.
- Thread the six leveling feet into the holes until the overall distance from the bottom of the foot to the top of the washer is approximately the height required to fit in the opening on under counter models. The height of Freestanding models will typically match the countertop.
- Carefully move the washer into an upright position. Be careful to distribute the weight evenly on the leveling feet when setting the washer upright.
- If installing a freestanding unit remove the back panel. Move the washer as close as possible to its final location but maintain access to the water connections and drain hose in the back. The water supply hoses will connect at the back of the washer. The wiring for the electrical connection will run from the rear of the unit through to the electrical box located behind the front toe kick panels.
- Adjust the leveling feet to level the washer and raise the unit to the desired finished height. A final adjustment may be required after the washer is placed in its final position.
- Additional accessories, like the Cold Water Drain Kits, should be installed at this time. Refer to the assembly instructions included with each kit. Individual kit instructions are also included on the User's Manual USB Thumb Drive (shipped with the washer) or online at Labconco.com.

## Hot Water Connection

A hot water supply line must be connected to the Glassware Washer.

- To prevent valve clogging, thoroughly flush the hot water lines from the supply source prior to connecting the washer to the water lines. The hot water inlet valve is located on the back of the washer base. The back panel of freestanding models must be removed to access the valve.
- The washer's hot water inlet valve is equipped with a male  $\frac{3}{4}$ -11  $\frac{1}{2}$  GHT fitting. Connect the hot water supply coming from the customer-supplied shut off valve using an appliance style braided hose with  $\frac{3}{4}$ -11  $\frac{1}{2}$  GHT fitting and  $\frac{1}{4}$ " minimum inside diameter. See Fig. 4-3.
- On undercounter installations, an extra 3' of service loop is recommended for the supply hose to allow the washer to be slid in or out of its operating position.

- Be careful not to kink the water supply tube when the washer is placed into its final location. If kinking occurs because of limited space between the back of the washer and the wall behind the counter, it may be necessary to use an elbow fitting at the washer's valve connection.

**Figure 4-3**

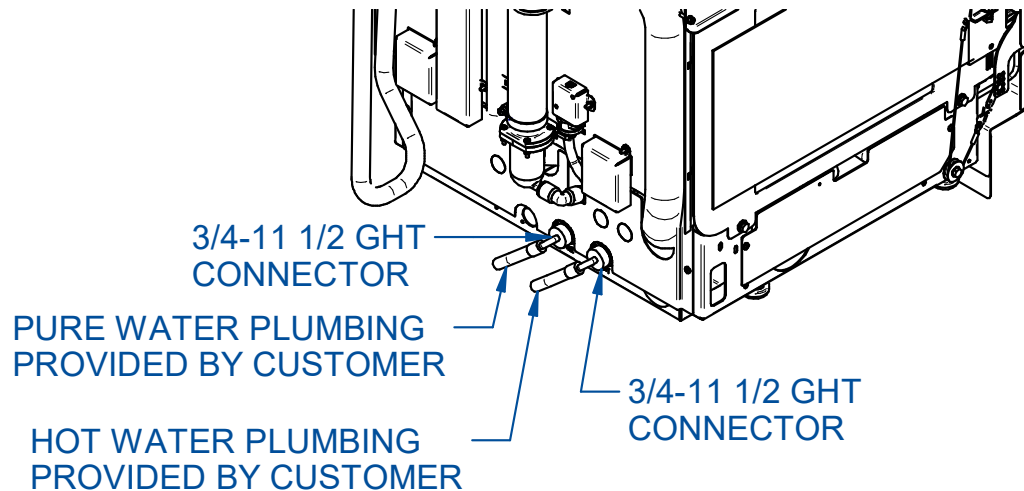

### Pure Water Connection

A pure water supply may be connected to the Glassware Washer if pure water rinse(s) are required. Please note that none of the Factory Programs are programmed to use Pure Water. If Pure water is required, a new program will need to be created. Refer to the Programming Section to learn how to create or copy and edit a program.

- To prevent valve clogging, thoroughly flush the pure water lines from the supply source prior to washer connection. The pure water inlet valve is located on the back of the washer base. The back panel of freestanding models must be removed to access the valve.
- The washer pure water inlet valve is equipped with a male  $\frac{3}{4}$ -11  $\frac{1}{2}$  GHT fitting. Connect the pure water supply coming from the customer-supplied shut off valve using an appliance style hose with  $\frac{3}{4}$ -11  $\frac{1}{2}$  GHT fitting and  $\frac{1}{4}$ " minimum inside diameter. See Fig. 4-3.
- On undercounter installations, an extra 3' of service loop is recommended for the supply hose to allow the washer to be slid in or out of its operating position. Be careful not to kink the water supply tube when the washer is placed into its final location. If kinking occurs because of limited space between the back of the

washer and the wall behind the counter, it may be necessary to use an elbow fitting at the washer's valve connection.



If you are not using purified water during the rinse cycles, you may disable the pure water system. Turning off the pure water system will not allow programming or operation of wash cycles with pure water. If your pure water supply is pressurized with sufficient flow, you may disable the purified water pump. Refer to [Section 6: Accessories Screen](#).

If the washer has been converted to a Mobile model and is moved to various locations, and if purified water is used, provisions must be made to use a flexible hose from a source of house-purified water. If a carboy is used, place the carboy on top of the washer or a carboy cart and move it with the washer. Take care not to let the hose kink or become damaged.

If the purified water source is a carboy, the washer's self-priming pure water pump will draw water from either the top or the bottom opening of the carboy. If the purified water supply feeds directly from the carboy top, make certain the hose is always submerged below the water line to eliminate air entry into the system. Verify the carboy is vented to permit proper flow from the carboy to the washer. Verify that all of the connections on the purified water system are air-tight.

## Drain Connection

Before continuing with this section, verify that the drain meets the requirements detailed in [Section 2: Drain Requirements](#).

Verify the drain line and connection meet all local plumbing codes.

The drain hose is installed at the factory. The hose provides a flexible coupling to the drain piping and can be secured with a spring or band hose clamp (A band hose clamp is provided with your washer).

Tubing or pipe 5/8" (1.6 cm) ID or larger should be used for the drain.



Do not route the drain to an elevation more than 36" (91 cm) above the pump discharge.

Do not reduce the size of the drain plumbing.

Do not remove the hose from the ties on the rear of the glassware washer.

If connecting to a sink drain the use of an air gap is strongly recommended for all installations to prevent the siphoning of wastewater into the washer. See Fig. 4-4.

The drain hose can be routed to either a sink or a floor drain. If you route the drain hose to a sink drain without using an air gap, the highest point of the drain hose must be above the highest water level in the sink. See Fig. 4-5.

**Figure 4-4**

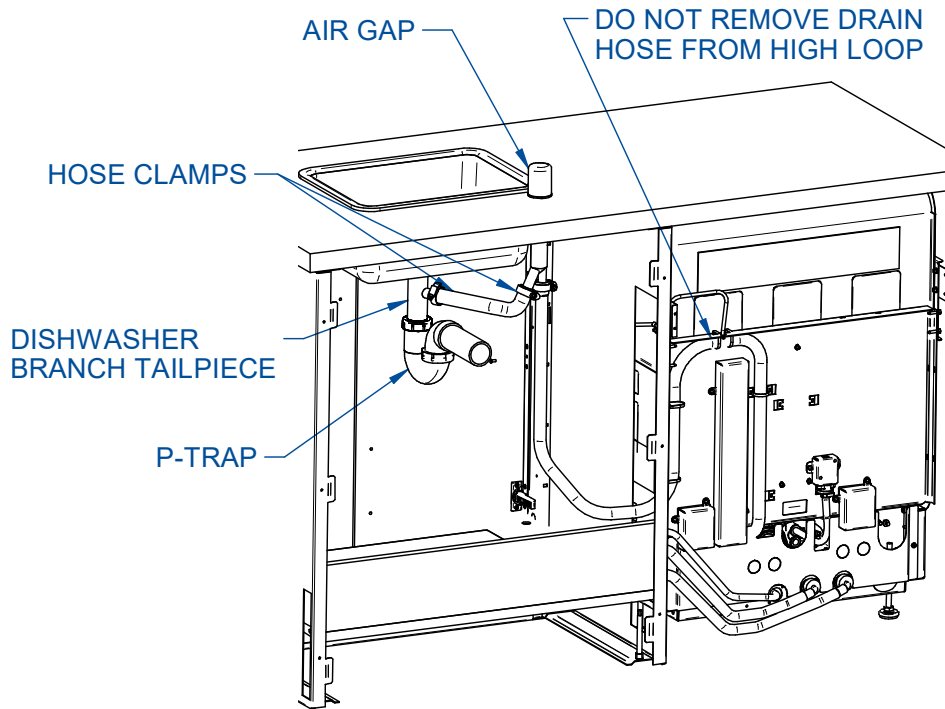

**Figure 4-5**

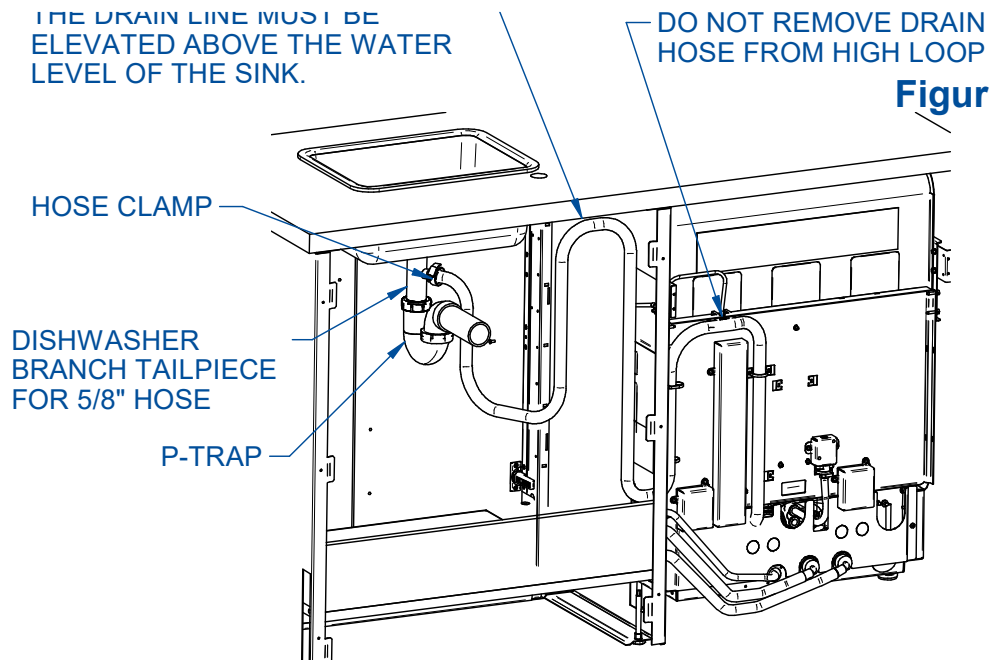

## Electrical Connection

Before continuing with this section, verify the power supply meets the requirements specified on the washer data plate (serial tag) and in [Section 2: Electrical Requirements](#). Undercounter and Freestanding Washers should be hard-wired directly into a junction box.

Verify compliance with all local electrical codes. Unless converting a 230 volt 3-phase unit to single phase, do not disturb any wiring internal to the washer.

If connecting two legs of a 3-phase power system to obtain single-phase power, consult a professional to verify all codes/standards are followed. An electrical professional can determine the appropriate connections for either a Wye or Delta connected power source.

The supply circuit for the 2.0kW single phase units must be at least 12 AWG 2-wire grounded cable and must be connected to a dedicated service with a 20 amp circuit breaker or fuse. Wiring must comply with all local electrical codes. Type THW or THWN wire may be used if it complies with local codes.

The supply circuit for the 6.0kW 3-phase units require at least 10 AWG 3-wire grounded cable and must be connected to a dedicated service with 30 amp circuit breakers or fuses.



If converting the 230 volt 6.0kW 3-phase unit to operate on 230 volt or 208 volt **single phase**, a dedicated 40 amp circuit breaker is required with 2 conductor grounded 8 AWG cable. Additional changes to the washer's internal wiring are required. Refer to the detailed conversion instruction tag secured to the wiring harness behind the front toe kick or the bottom image in Fig. 4-7 on the following page.

If the unit came with a factory installed power cord, with the power to the outlet off, simply plug it into the appropriate power source outlet, otherwise refer to Figs. 4-6 and 4-7 and follow the steps below to hard wire the washer to an appropriate power source.

- Make sure electrical power is turned off.
- Remove the lower toe kick panels on the washer by removing the six screws.
- Remove the electrical box by loosening the two screws on each side of the washer base and removing the one screw located at the lower center of the box.
- Without disconnecting the existing wiring, carefully pull the electrical box out enough to gain access to back side.

- Carefully route the electrical supply wire through the strain relief clamp located in the back center of the base to the strain relief clamp on the back of the electrical box. Note: this step is best accomplished using a fish tape. **Figure 4-6**

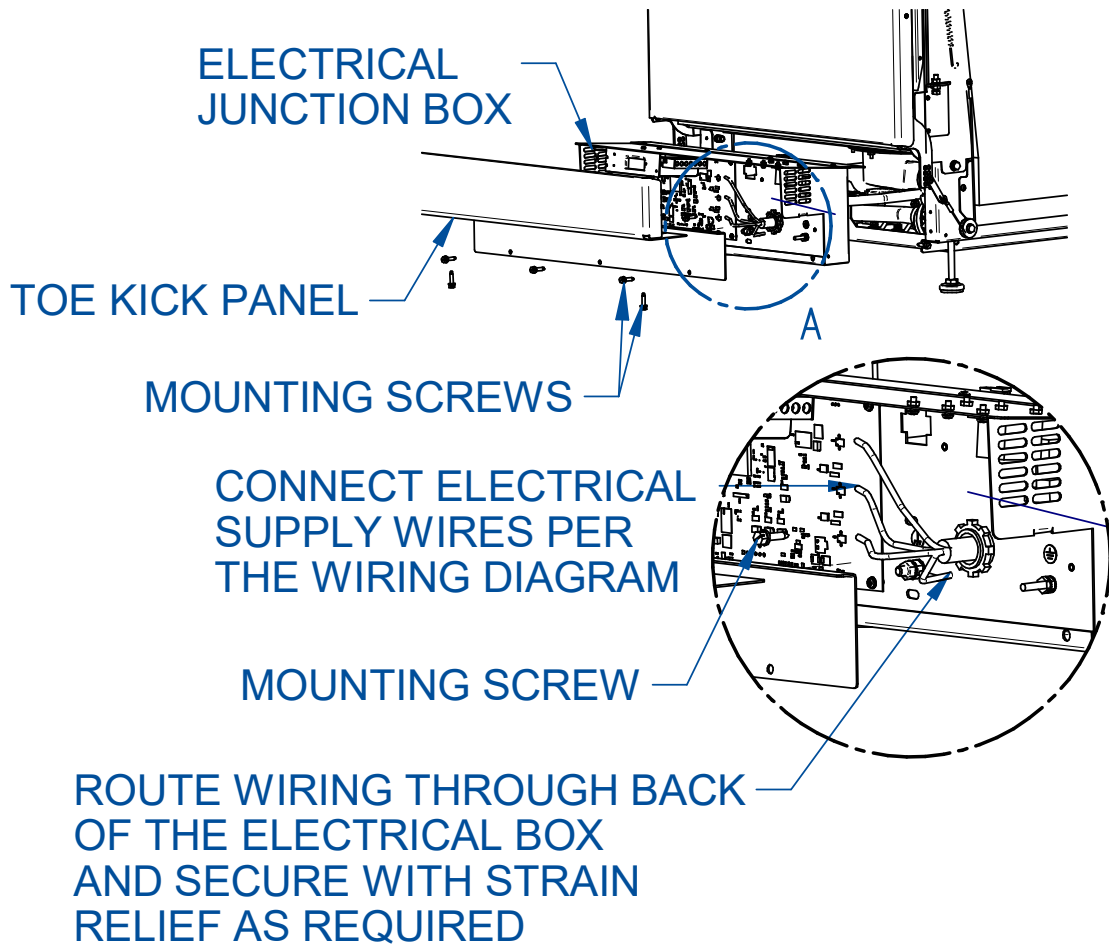

- Connect the customer-supplied service wires to the appropriate wire nuts on the main wiring harness. Refer to the appropriate wiring diagram shown below. Make certain the wiring connections match the wiring diagram for the voltage of the washer being installed. Reference Fig. 4-7.
- Connect the ground wire from the supply cable to the 1/4-20 ground stud on the electrical box using a 1/4" lug or ring terminal.

## 120/208/230v 1 PHASE SERVICE

Figure 4-7

### CONNECT TO WIRE NUTS

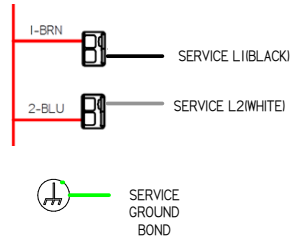

## 208/230v 3 PHASE SERVICE

### CONNECT DIRECTLY TO TERMINAL BLOCK

#### 208/230VAC 3 PHASE USA SERVICE

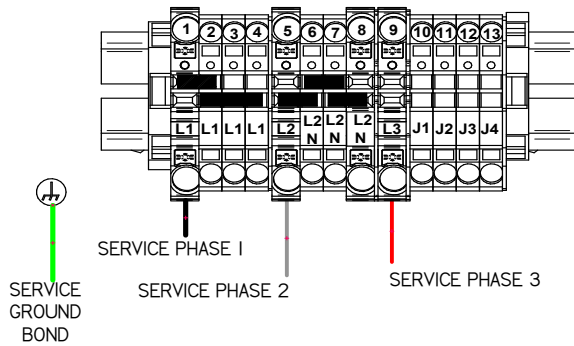

NOTE: WITH HIGH LEG DELTA (WILD LEG) 3 PHASE POWER, CAP NEUTRAL AND DO NOT USE. NO OTHER WIRING CHANGES REQUIRED. SEE 208V 3PH ABOVE

#### 208/230VAC 3 PHASE EU SERVICE

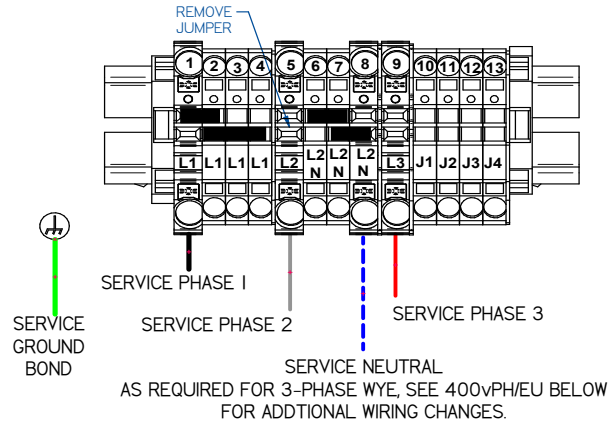

NOTE: WITH HIGH LEG DELTA (WILD LEG) 3 PHASE POWER, CAP NEUTRAL AND DO NOT USE. NO OTHER WIRING CHANGES REQUIRED. SEE 208V 3PH BELOW

**IMPORTANT! FOR EU INSTALLATION**

TERM.#	230V 1PH	208V 3PH	400V 3PH/EU
1			
2			
3			
4	4A-BRN		
5			30-RED
6			
7			
8			
9		4A-BRN	4A-BRN
10		29-BLK	
11	29-BLK		29-BLK
12	30-RED	30-RED	
13			

**REMOVE JUMPER 3**

- Secure the supply power cable with the two strain relief clamps at the back of the electrical box and the back of the base.
- Carefully reinstall the electrical box making sure the slack from the cable does not interfere with the washer's internal wiring, the pump fans or the drain valve linkage. Use cable ties to secure the wire as needed.
- Replace the toe kick panels.

## Ethernet Connection

Software updates can be uploaded and data log files that are stored in the Glassware Washer can be downloaded via an Ethernet connection. For this to be possible, a working Ethernet connection must first be established. The following steps must be completed to connect to a Local Area Network (LAN):

- A user supplied Ethernet Cable must be connected to the Ethernet adapter located to the right of the HEPA Filter within the washer's side cabinet and to a LAN with working internet service.
- The cable can be routed under the shelf and out the back panel of the cabinet. There are knockouts in the bottom of the back panel to route the cable.
- Once the washer is installed refer to Network section of Chapter 6 for settings.

## Install the Washer

Once service lines are properly connected and the electrical service is off, the washer can be moved into its final position. If installing an undercounter model make sure the mounting tabs at the top of the washer tank are bent out towards the front of the unit. As you push the unit in place, make sure service connections are not kinked or pinched. Once in place, verify the unit is level in both directions. The final height adjustment can be made at this time. Undercounter models must then be attached to the counter top. Freestanding model's height can be adjusted to match the adjoining countertop or as needed. Follow the instructions below to level and secure the washer.

### Leveling the Washer

- Locate the Door Unlock Pin used to open the door previously.
- Push the Door Unlock Pin into the hole in the control panel until the door opens. See Fig 4-1.
- Retain the Door Unlock Pin for emergency access in case of power failure.

- Turn the four leveling feet, as needed, to level the washer.
- Level the washer side-to-side by placing a short level on the inside top edge of the door. See the Fig. 4-8 for the placement of the level.
- Check the level front to back by placing a level on the lower rack rails.
- When the washer is level, check the operation of the washer door for alignment with the washer tank.

**Figure 4-8**

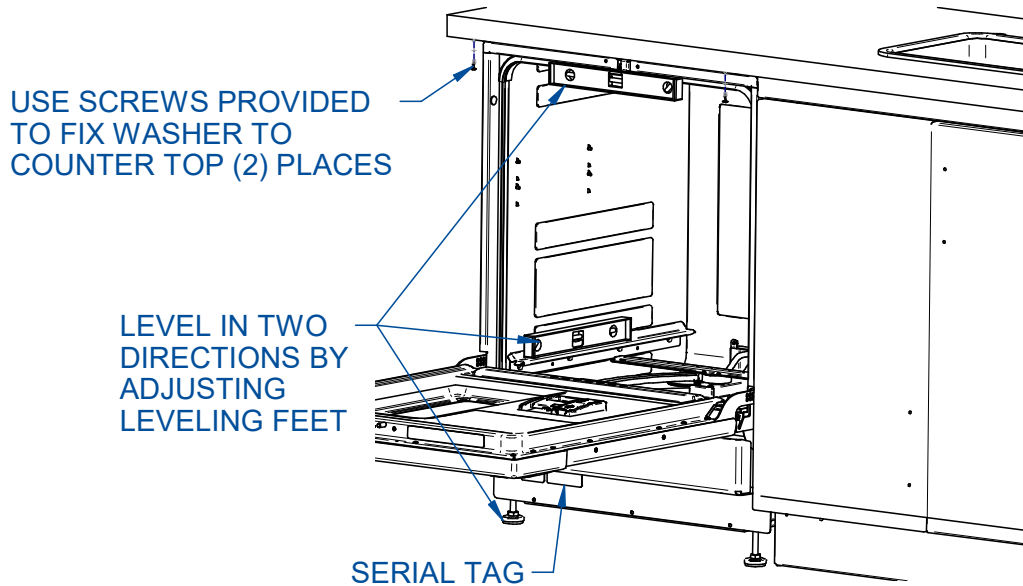

- Verify the door is centered in the opening by closing it slowly. If the door hits the right side of the tank, raise the right front corner of the washer. If the door hits the left side of the tank, raise the left front corner of the washer.
- The racks can now be reinstalled.
- 

### Securing the Washer to the Countertop

- If an undercounter washer model, two screws are provided to attach the front of the washer to the underside of the countertop or work surface. After the washer is level, in its final position and the washer door is properly centered, install the two screws through the mounting tabs at the top of the tank, then into the bottom of the counter top to stabilize the unit as shown in the Fig. 4-8.
- Once the washer is in a secure position the toe kick panels can be reinstalled as well as the lower filler panel if required to hide the space below the washers base.

## Testing Your Washer

Now that you have made the required water and electrical connections to your washer, a series of diagnostic steps are provided in this section to test the operation of the washer.

Before turning on the washer, make certain the supply water is turned on and no packing material remains inside the washer.

The electrical service to the washer can now be turned on.

### Running Diagnostics

To verify the washer is operating properly, perform the diagnostics procedure detailed below. This should take approximately 10 minutes to complete. Refer to Fig. 4-9 to familiarize yourself with the control panel before you begin this procedure.

- From any screen touch the HELP Icon.
- Touch the Diagnostic icon.
- Scroll down to Manual/Auto Run Test, select each component and confirm.
- The component selected will activate and test the low voltage components to verify their operation.
- Confirm that all tested components passed.
- Scroll up to Fill All The Way, select and confirm. The washer will fill to the set point with hot water. When complete, the water level should touch but not cover the heaters. If needed the test can be stopped by selecting Fill All The Way again and confirming.
- Once the tank is full of water, make sure the door is closed, select and confirm Wash Pump. The wash pump should spin up for approximately 10 seconds.
- Select Drain All the Way and confirm. The washer should drain for approximately 3 minutes.

### Verification

Once the diagnostic tests are complete, scroll through the status of each line item to verify that it passed the tests.

If there are any Fails refer to [Section 10: Troubleshooting](#) for assistance in determining root cause and corrective action.

If the washer passed all tests, continue to [Section 5: Performance Features](#) to become familiar with the features and controls of the glassware washer.

**Figure 4-9**

The figure shows two screenshots from a washer's control interface. The top screenshot is the 'Help' menu, which includes icons for Home, Settings, and a question mark labeled 'HELP'. Below the 'Help' title are four options: 'About', 'Diagnostics', 'Resources', and 'Backup/Restore'. A blue arrow labeled 'DIAGNOSTICS' points to the 'Diagnostics' icon. The bottom screenshot is the 'Diagnostics' screen, which displays a table of test results. A blue arrow labeled 'AUTO TEST' points to the 'Manual/Auto Run Tests' section. A blue arrow labeled 'PASS/FAIL' points to the 'TEST RESULT' column. At the bottom of the table are 'Back' and 'Export USB' buttons.

Diagnostics	
WASHER COMPONENT	TEST RESULT
▶ SERVICE CYCLE	
▶ <b>Manual/Auto Run Tests</b>	
▶ FILL VALVE (HOT TAP)	PASSED
▶ FILL VALVE (COLD TAP)	PASSED
▶ DI VALVE (PURE)	PASSED
▶ DI PUMP / VALVE (PURE)	PASSED
▶ WASH PUMP 1	PASSED

### High Elevation Installations

If the washer is installed at an elevation above 2000 meters (6561 feet), the maximum programmable temperature set point MUST be changed from 93°C to 88°C. See [Section 5: Calibration – Setpoints](#) for instructions to make this change.

## 5: Performance Features

---

FlaskScrubber Series Glassware Washers come standard with a lower spindle rack for direct injection of water into narrow neck glassware. Standard features included with all FlaskScrubber Vantage Series Glassware Washer are HEPA filter forced air-drying, conductivity sensor, Automatic Detergent dispense, Automatic Rinse-Aid dispense, Ethernet and printer connectivity. The unit also comes standard with a pure water connection, which includes a diaphragm pump to draw from a non-pressurized pure water source. Each washer is designed and manufactured to thoroughly clean your laboratory glassware and accessories.

The washer provides a touchscreen display that is pre-programmed with multiple wash cycles. Including the water saving Pure Sense program. Up to 200 user-defined programs can be created and customized. Almost every aspect of the wash programs can be modified including steam generation, water source, temperature and segment times. The FlaskScrubber Vantage Series has a viewing window with an LED light allowing you to visually monitor the operation of your washer. All FlaskScrubber Vantage Series Glassware Washers have a stainless-steel wrapper so it can be installed as a freestanding unit or under counter.

The spindle rack is designed to inject water during wash and hot air during dry into narrow-necked glassware such as volumetric flasks, Erlenmeyer flasks, graduated cylinders, Kjeldahl flasks, test tubes, BOD bottles and digestion tubes. Two sizes of spindles are provided with the rack: (36) 0.25" (6.35 mm) OD and (10) 0.125" (3.18mm) OD spindles. The spindles or the spindle support tubes can be removed and replaced with plugs or other accessories to configure the rack to meet your needs.

In addition to the spindle rack provided, optional racks and inserts are available to expand the washer's capacity to accommodate many types of glassware.

## 6: CleanWorks™ Operating System

---

The Glassware Washer operating system provides clear status information on the touch screen and user control with the keypad (Fig. 6-1). Read this section along with [Section 7: Using Your Glassware Washer](#) to fully understand the features and controls of this product.

### Control Panel

Figure 6-1



### Touch Screen Display

The touch screen displays system operating parameters, set-up parameters and alarm messages. All user-control interface will take place via the touch screen.

### Open Button

If the glassware washer is powered and not in operation pressing this button will unlatch the door. Pressing this button during a wash cycle will prompt for user confirmation to pause the cycle and then open the door. Once confirmed, the cycle will pause for 7 seconds to allow the wash pump to stop and then unlatch the door lock. Press and hold the Open button for 15 second to perform a power reset.

### On / Standby LED Indicator

Blue LED indicator light designates the current status of the system.

- 1 flash per second = Initial power up (loading operating system)
- Slow pulse = Touch screen in low power mode (screen timeout)
- ON = Unit is plugged in and touch screen is in active mode

- Off = Unit is unplugged

### Initial Power Up

When the glassware washer is initially connected to a power source, the On / Standby LED will begin flashing (1 flash per second). The display will remain OFF for the first 10 to 15 seconds, then animated graphics will appear. It will take approximately 90 seconds for the operating system to fully load.

### Home Screen

After initial power up, the Home screen will be displayed. Most of the general operation and system monitoring can be done from the Home Screen.

**Figure 6-2**

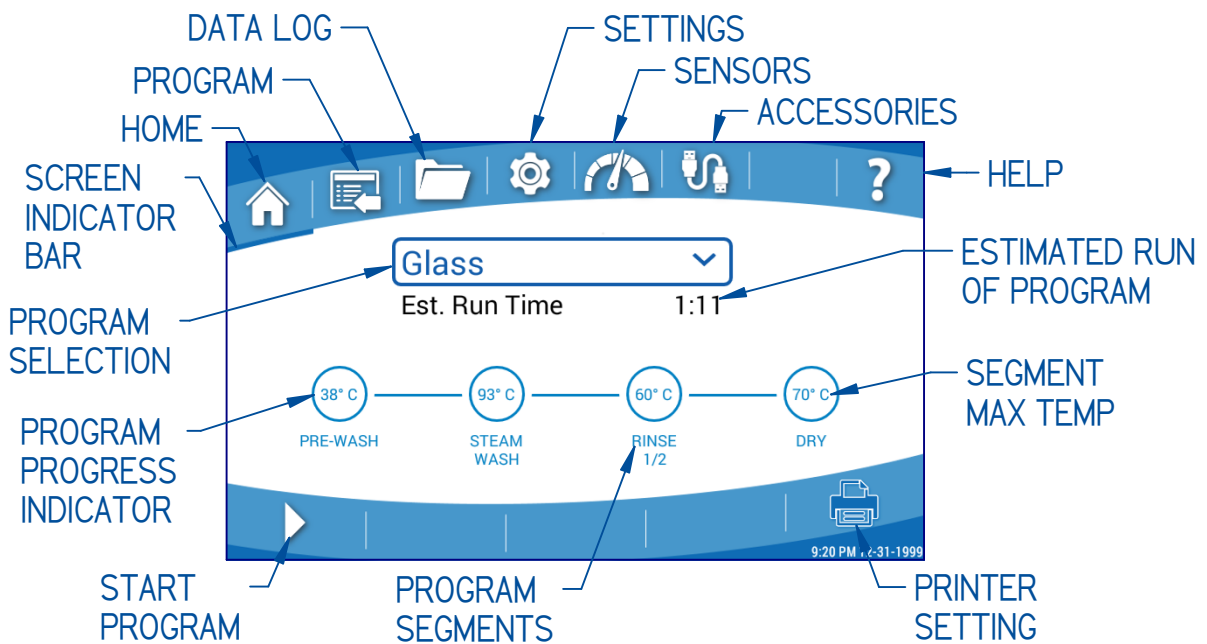

The menu screen tabs are displayed across the top of each screen as shown on the Home Screen in Fig. 6-2.

You can move between menu screens by either touching the desired tab or swiping across the screen from left to right or right to left.

### Menu Tabs

- Home
- Programs
- Data Logging
- Settings
- Sensors
- Accessories
- (Empty)
- Help

## Screen Indicator Bar

A thin blue indicator bar will appear under the icon of the menu screen that is currently being displayed.

## Program Selection

Touch the Program Selection bar to display all programmed cycles. If the list is long, swiping up/down will scroll the list. Touch to select the desired program. The Home Page will then display the Program Progress Indicator for the selected program. The Program Progress Indicator will display each segment of the program, along with the maximum programmed temperature of each segment. The estimated run time will display just beneath the program name.

## Printer (Accessory)

Touch the Printer Setting Icon (Fig. 6-2) to display the following Print Options:

- Disable: No data will print
- Summary
  - Prints a summary of the critical data from the wash cycle
- Detailed with Summary
  - Prints Summary data plus individual segment data

**Summary** {

```
Device: ChemLabWash1
Log File: Log 07-15-2020
Program: Analytical
Start: 07/15/2020
Run Time: 00:03:43:51
Final Water Quality: 11 µS/cm
Alerts: None
Status: Complete
```

**Detailed** {

```
Pre-Wash: Cold Water
Max Temp: 35 C
Detergent: None
Rinse Aid: None
Wash1: Hot Water
Max Temp: 55 C
Detergent: Cup
Rinse Aid: None
Wash2: Hot Water
Max Temp: 90 C
Detergent: 25 mL RA123
Rinse Aid: None
Rinse1: Hot Water
Max Temp: 40 C
Rinse Aid: None
Rinse2: Pure Water
Max Temp: 40 C
Rinse Aid: None
Dry
Max Temp: 65 C
SpeedVent: Enabled
```



In the following sections, touchable icons/screen buttons are shown as **[BLUE WITH BRACKETS]**. Screen selections are shown as *green italics*.

## Start Program

Touch the *Start Program* Icon (Fig. 6-2). A pop-up confirmation will display, which will show the selected program, the data acquisition rate, the printer format, and any programmed time delay. Time delay settings can be modified from this screen by touching the time and selecting a new delay time.

If all settings are correct press **[OK]** to begin the program. Once the program begins, the Home Screen will change as shown in Fig. 6-3. The system temperature is displayed next to the current running program, the total estimated time remaining to complete the program and the conductivity level is displayed.

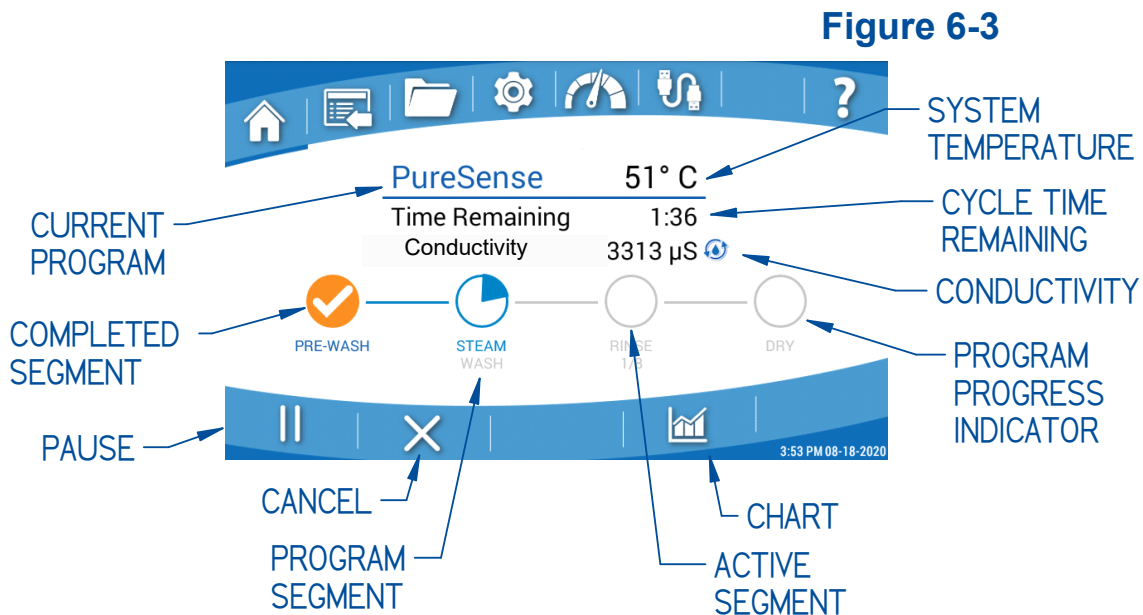

## Program Progress

The Program Progress Indicator graphically displays the progress of each segment of the program as the washer progresses through the cycle. Once a segment is complete, a blue check mark is shown. If a non-fatal alarm occurred during the segment, a yellow check mark is displayed. If the program is canceled or any fatal alarm occurred (automatically ends the cycle) a red **X** will be displayed. A single touch to the Active Segment will display the current segment step and time remaining of that step within the running segment i.e. Fill/Heating/Wash/Drain. The step information will be displayed for 10 seconds, or until the Active Segment is touched again.

## Skip Segment

The Glassware washer has the ability to skip an active segment. Press and hold the Active Segment for 3 seconds to display the *SKIP STEP?* confirmation. Touch **[OK]** to skip the active segment. If the skipped segment is a wash or rinse the glassware washer will perform a drain step and then continue with the next programmed segment. When complete, the segment will display a yellow check mark. Press the yellow check mark to display the non-fatal error. A non-fatal Skipped Segment Error (SS) will be recorded in the data log.

## Pause

Touch the *Pause* Icon (Fig. 6-3). A pop-up confirmation will display, select **[OK]** to pause the wash cycle, or select **[Cancel]** to return to the Home Screen. The program will stop and the *Start Program* Icon will return. Once the program is paused the door can be opened by pressing the OPEN button (see Fig. 6-1). To resume the wash cycle, close the door and touch the *Start Program* Icon, press **[OK]** to confirm. The washer will resume the cycle once the internal temperature stabilizes. When the cycle resumes the estimated time remaining will begin when the pre-pause system temperature is reached. When complete, the segment will display a yellow check mark. Press the yellow check mark to display the non-fatal error. A non-fatal Program Paused Error (PP) will be recorded in the data log.

## Cancel

Touch the *Cancel* Icon (Fig. 6-3). A pop-up confirmation will display, select **[OK]** to cancel the wash cycle, or select **[Cancel]** to return to the Home Screen. When a program is cancelled the washer will drain and when complete, display a red **X** at the segment in which it was cancelled. Press the red **X** to display the fatal error. A Program Canceled Error (PC) will be recorded in the data log.

## Chart

Touch the *Chart* Icon to display a chart of the current program's data set as defined by the systems available sensors and the user's requirements. See [Chart Data File](#) later in this section for more details.

## Program Screen

The Program Screen allows the user to view the parameters of all programs. New user-defined programs can be created, edited or deleted from this screen. All factory programs are locked and cannot be edited, but any program can be copied, renamed and then modified. See Fig. 6-4. All changes to non-factory programs will be stored in memory until modified or deleted.



If a FACTORY RESET is performed, all user programs will be erased and the factory settings will be reinstated. . Refer to the [Back Up and Restore](#) in the [Help](#) screen for details on saving custom programs before performing a Factory Reset.

Figure 6-4

Name	Run Time	Last Modified	
Extreme	2:50	Aug 26, 2020	
PureSense	1:30	Aug 26, 2020	
Rinse Only	0:07	Aug 26, 2020	
Dry Only	1:00	Aug 26, 2020	
Eco Wash	0:44	Aug 26, 2020	
Clean Washer	0:36	Aug 26, 2020	
Plastic	0:40	Aug 26, 2020	

Buttons: New, View, Copy, Delete

Fig. 6-4 shows the Program Screen. To edit, copy, or delete a program, first touch the desired program to highlight it. In Fig. 6-4 the program “Extreme” is highlighted. To create a new program, touch [\[New\]](#).

Fig. 6-5 illustrates the user-customizable program parameters and limits for each segment.

The FlaskScrubber Vantage Series includes Auto Detergent Dispense; therefore, a second Wash (*Wash2*) can be programmed, and liquid detergent can then be dispensed in any wash segment (0-100ml). The FlaskScrubber Vantage Series also includes Auto Rinse Aid Dispense; therefore, rinse aid can be dispensed in any rinse segment (0-40ml).

**Figure 6-5**

SEGMENT	TIME(min)	TEMP (°C/°F)	H2O SOURCE***	DOOR CUP / AUTO DETERGENT	DOOR CUP / AUTO RINSE-AID
Delay	0-720				
Pre-Wash	0-40	25-93 / 77-200	Hot or Pure	D-Cup* / 0-130 ml	
Steam	0-20				
Wash 1	0-40	25-93 / 77-200	Hot or Pure	D-Cup* / 0-130 ml	
Wash 2^	0-40	25-93 / 77-200	Hot or Pure	D-Cup* / 0-130 ml	
Rinse 1-8	0-40	25-93 / 77-200	Hot or Pure		6ml** / 0-130 ml
Dry	0-240	25-80 / 77-176			
SpeedVent	ON/OFF				

^ Factory Programs with Wash 2 are only available when Auto Detergent Dispense Kit is installed.

\* Detergent dispensed from the Door Cup can only be specified in one (1) Pre-Wash or Wash segment.



\*\* Rinse-Aid dispensed from the Door Cup can be dispensed in 1 mL increments up to 6 mL Rinse-Aid can only be dispensed from the Door Cup in one (1) Rinse segment.



\*\*\* Factory Programs are set to use Hot Water for all fill cycles. To use Pure Water a new program should be created.

[View a Program](#)

From the **Program** Screen touch the program you wish to view; the line will be highlighted. If this is the correct program, press **[View]** (for a locked program) or **[Edit]** (for an unlocked program). The program parameters will be displayed. See Fig. 6-6.

**Figure 6-6**

Program Name: <u>Glass 02</u> <span style="float: right;">8/12  </span>					
SEGMENT	TIME	TEMP (° C)	H <sub>2</sub> O SOURCE	DETERG.	RINSE AID
PRE-WASH	0:05	38	H	NONE	-
STEAM 1	0:10	-	-	-	-
WASH 1	0:10	60	H	CUP	-
RINSE 1	0:05	38	H	-	4 CUP
RINSE 2	0:05	60	H	-	NONE
DRY	0:30	70	-	-	-

Back Save

## Edit a Program

From the **Program** Screen touch the program you wish to edit; the line will be highlighted. If this is the correct program, press **[Edit]** (only allowed on an unlocked program). The program parameters will be displayed. See Fig. 6-7.

**Figure 6-7**

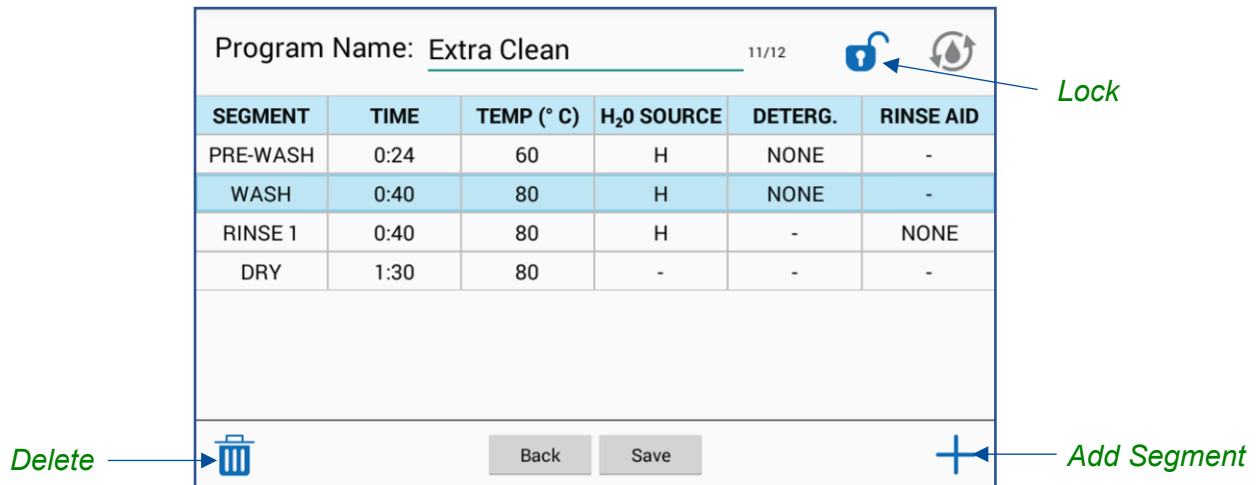

To add a segment to the program, touch the **Add Segment** icon. A pop-up will display segments that can be added. Based on the washer model and/or accessories installed, a limited number of specific segments are allowed (limitations are found in Fig. 6-5). Segments added will automatically be ordered correctly, for example a new Rinse segment will be placed after the final Wash segment or if one or more Rinse segments already exist, will be placed after the final Rinse segment. After selecting the segment to add, the Segment Wizard will prompt you to enter each required parameter.

To delete a segment from the program, touch the segment, then touch the **Delete** icon.

To modify a segment parameter, such as temperature, time, or detergent/rinse-aid dispense, touch the parameter value. A pop-up will appear, which allows the parameter to be adjusted within allowable limits. Allowable limits are found in Fig. 6-5. After making the desired change, touch **[OK]**.

To lock or unlock a user program, touch the **Lock** icon. Locking a program prevents modification/deletion when security is enabled for Programs.

After all changes are made, touch **[Save]**. If **[Back]** is touched before saving the changes, you will be prompted that there are unsaved changes. To exit the program edit screen without saving the changes, touch **[OK]**.

## Create a new program

1. Touch **[New]**. A blank Program Screen will be displayed.
2. A default program name will be assigned. To change this name, touch the Program Name field and edit the name. Touch **[OK]** to save the new name.
3. Touch the **Add Segment** icon.
4. A pop-up will display segments that can be added. Based on the washer model and/or accessories installed, a limited number of specific segments are allowed (limitations are found in Fig. 6-5). Segments added will automatically be ordered correctly, for example a new Rinse segment will be placed after the final Wash segment or if one or more Rinse segments already exist, will be placed after the final Rinse segment. After selecting the segment to add, the Segment Wizard will prompt you to enter each required parameter. Several Segment Wizard prompt screens are shown in Fig. 6-8.
5. In the Segment Wizard, swipe up or down to change the set point values of each parameter. Touch **[Next]** to move to the next parameter. See Fig. 6-5 for all segments and their set point ranges.
6. Once the parameters of the Segment have been entered another Segment can be added by repeating steps 3 – 5.
7. Once all required Segments have been entered touch **[Save]**. The new program will be listed at the top of the Program Screen when sorting by **Last Modified**.

Figure 6-8

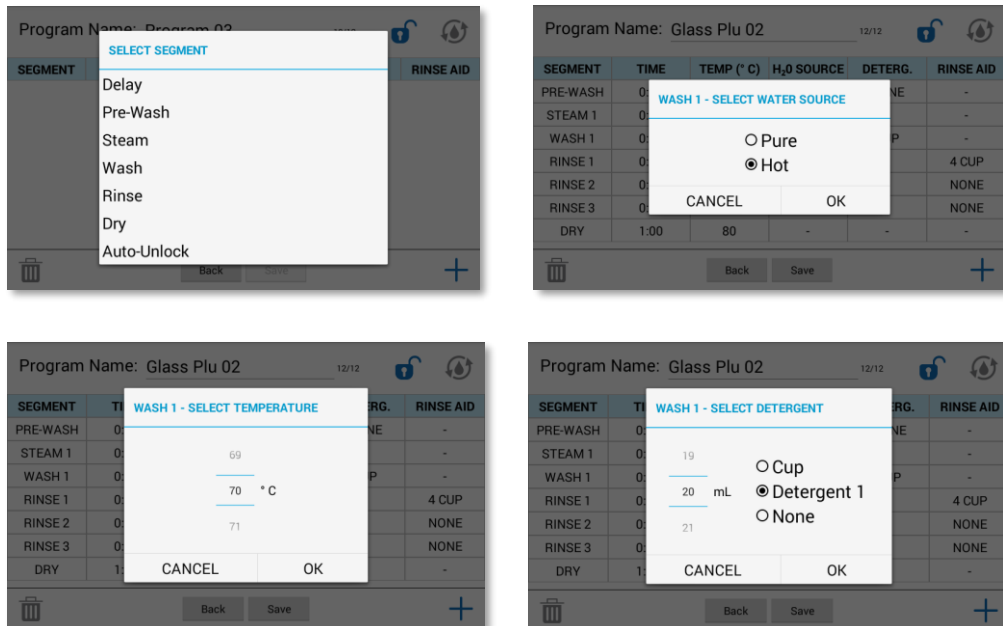

## Copy and Edit a Program

1. From the Program Screen highlight the program you wish to copy by touching the program line.
2. Touch **[Copy]**. An exact copy of the Program Screen will be displayed, except the Program Name field will default to a new name.
3. To edit the Program Name, touch the Program Name field and type the new name. Touch **[OK]** to save the new name.
4. To edit a segment, touch the value of the parameter you wish to edit. A pop-up will appear to modify the parameter. Swipe up or down to change the value, then touch **[OK]**.
5. To delete a segment from the program, touch the segment, then touch the *Delete* icon.
6. To add a segment to the program, touch the *Add Segment* icon. A pop-up will display segments that can be added. Based on the washer model and/or accessories installed, a limited number of specific segments are allowed (limitations are found in Fig. 6-5). Segments added will automatically be ordered correctly, for example a new Rinse segment will be placed after the final Wash segment or if one or more Rinse segments already exist, will be placed after the final Rinse segment. After selecting the segment to add, the Segment Wizard will prompt you to enter each required parameter.
7. Once all required segments have been entered touch **[Save]**. The new program will be listed at the top of the Program Screen when sorting by *Last Modified*.

## Delete a Program

From the Program Screen select the program you wish to delete; the line will be highlighted. If this is the correct program, touch **[Delete]**, then confirm you are deleting the correct program by selecting **[OK]**.



Factory programs are locked and cannot be deleted.

## Sorting Programs

From the Program Screen touch either **[Last Modified]** or **[Last Run]**, notice each touch toggles between the two selections. When **[Last Modified]** is displayed, the most recently modified program will display at the top of the program list. When **[Last Run]** is displayed, the most recently used program will display at the top of the program list.

## Log Data

Depending on the model, the data log will collect up to 13 parameters for each program at a user-selected data rate. The Data Log Screen allows the user to sort and view up to six sets of the collected data.



Although the Data Log Screen only allows viewing of up to 6 parameters, all parameters are permanently stored with the Data Log, and will be viewable when the log file is downloaded and viewed on a computer.

See Fig. 6-9. Each file will be named sequentially as follows “LOG\_YYYY-MM-DD\_XX”, where YYYY = Year, MM = Month, DD = Day, and XX = 01 to 99 for the first through 99<sup>th</sup> log of that specific day. The data log default rate is 10 seconds. The default data rate can be changed in the Settings Screen by selecting *Data Log*, and then change the data collection rate from the drop down menu.

A data log can be selected from the list by touching the data log file name. When a data log has been selected, the row will be highlighted as shown in Fig. 6-9. When selected, the buttons along the bottom of the screen will activate (**[View]**, **[Chart]**, **[Export]**, **[Delete]**). If a data log is currently running (collecting data), the *Running Man* icon will appear to the left of data log file name.

**Figure 6-9**

The screenshot shows a mobile application interface for data logging. At the top is a blue navigation bar with icons for home, list, folder, settings, gauge, USB, and help. Below the bar is the title "Data Logging". A table lists log files with columns for file name, program name, and file date. The second row is highlighted in light blue. At the bottom are four buttons: View, Chart, Export, and Delete.

	Program Name	File Date
Log_2020-08-03_21	Program 01	Aug 03, 2020
Log_2020-08-03_20	Program 01	Aug 03, 2020
Log_2020-08-03_19	Program 01	Aug 03, 2020
Log_2020-08-03_18	Program 01	Aug 03, 2020
Log_2020-08-03_17	Program 01	Aug 03, 2020
Log_2020-08-03_16	Program 01	Aug 03, 2020
Log_2020-08-03_15	Program 01	Aug 03, 2020

## View Data File

1. From the Data Log Screen, highlight the Log to view by touching the Log name.
2. Touch **[View]**.
3. Six columns showing data from six user-defined data points will be displayed.
4. Swipe the screen up or down to scroll through the data.
5. Select **[Bottom]** to snap to the bottom of the log file.
6. Select **[Top]** to snap to the top of the log file.
7. Select **Most Recent First** to display the newest data at the top of the log file.
8. Select the **Customize** icon at the bottom right corner of the screen to change the data shown in the any of the six columns. See Fig. 6-10. Less than six data columns can be displayed; however six is the maximum number for display.
9. Select the **Information** Icons by the Alarms or Step code headers to display a table showing the code definitions.
10. Data from the displayed columns can be searched by pressing the search icon as shown.

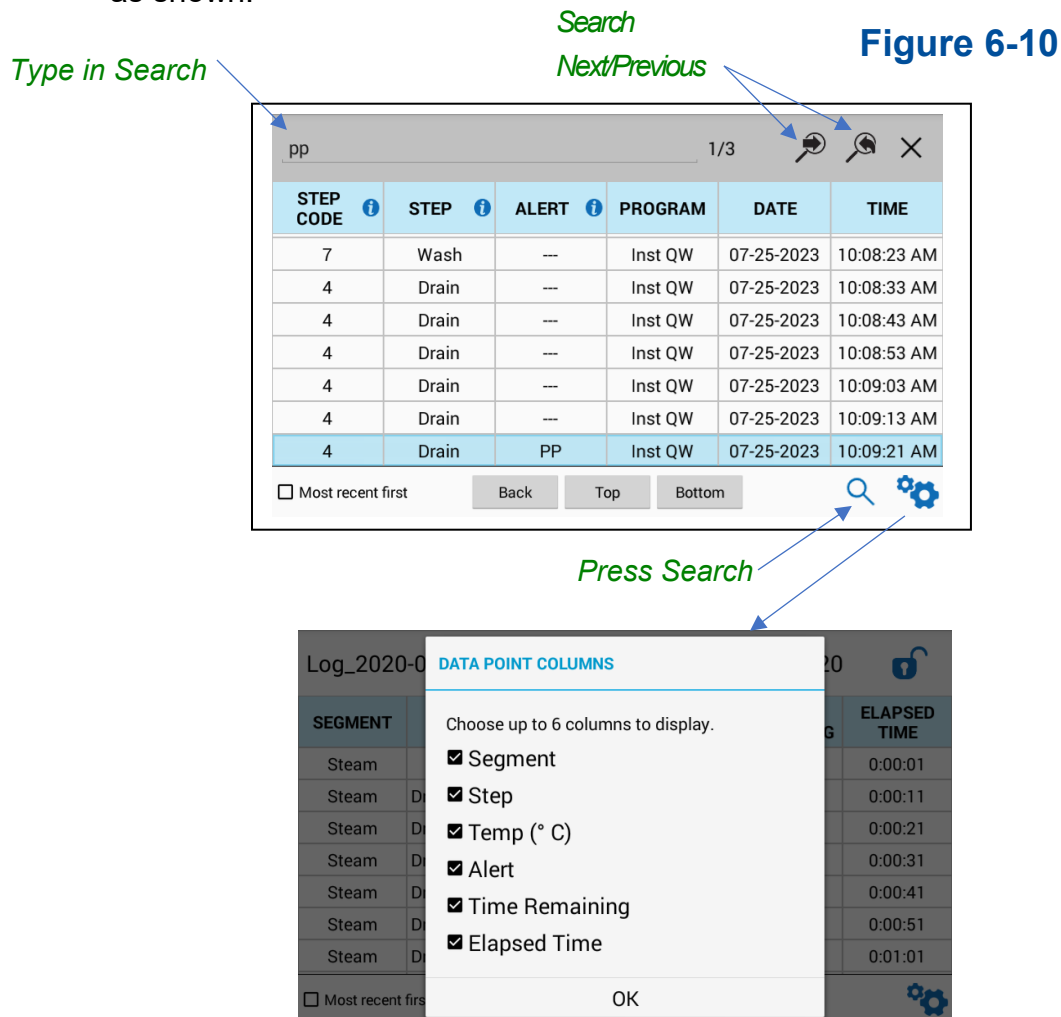

## Chart Data File

1. From the Data Log Screen, highlight the Log to chart by touching the Log name.
2. Touch **[Chart]**.
3. The chart will display the system temperature and/or conductivity vs time. See Fig. 6-11.
4. The chart can be manipulated by zooming in and out or swiping side to side.
5. If your washer is equipped with a conductivity sensor, to show or hide data on the chart, touch the drop down at the bottom of the screen and select the data to display.



The chart view will display the value of individual data points, when zooming in to a specific set of data (Ref Fig. 6-11). The values will display next to each data point when zoomed to allow 10 data points on the chart. When more than 10 data points are visible, the individual values will automatically disappear.

**Figure 6-11**

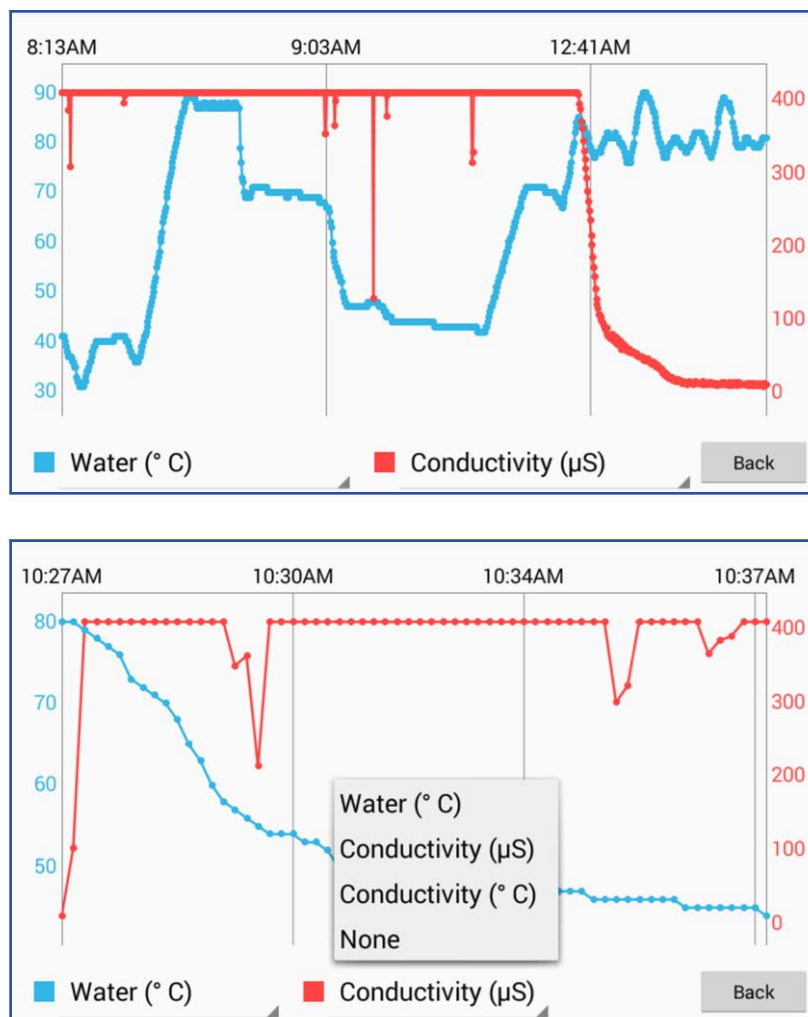

## Export Data File

Exported files will include all data as shown in Fig. 6-12.

1. Insert Flash Drive into USB connection below the display and wait for recognition. Upon recognition, a pop-up will display. Touch **[OK]**.
2. From the Data Log Screen, highlight the log to export by touching the log name.
3. Touch **[Export]**.
4. Select the file format (.CSV or .PDF), then touch **[OK]**.
5. Once the export is complete, the USB can be removed.



Touching and holding a file name for 3 seconds enables multiple file selection. Multiple data logs can then be selected and exported at the same time. During multiple selection mode, the option to *Select All* will be available at the top of the Data Log Screen.

**Figure 6-12**

Date	Time	Elapsed Time	Time Remaining	Segment	Step	Step Code	Temp (° C)	Conductivity (uS)	Conductivity Temp (° C)	Alert
Labconco Corporation Program: Intense FlaskScrubber Vantage Series Glassware Washer										
8/6/2020	7:32:02 PM	0:00:01	3:05:00	Wash	Drain	4	47	356	47	
8/6/2020	7:32:12 PM	0:00:11	3:05:00	Wash	Drain	4	47	356	47	
8/6/2020	7:32:22 PM	0:00:21	3:05:00	Wash	Drain	4	46	358	46	
8/6/2020	7:32:32 PM	0:00:31	3:05:00	Wash	Drain	4	46	357	46	
8/6/2020	7:32:42 PM	0:00:41	3:05:00	Wash	Drain	4	46	359	46	
8/6/2020	7:32:52 PM	0:00:51	3:05:00	Wash	Drain	4	46	354	46	
8/6/2020	7:33:02 PM	0:01:01	3:04:00	Wash	Drain	4	46	355	46	
8/6/2020	7:33:12 PM	0:01:11	3:04:00	Wash	Hot Fill	2	46	355	47	PP
8/6/2020	7:33:22 PM	0:01:21	3:04:00	Wash	Hot Fill	2	46	355	47	
8/6/2020	7:33:32 PM	0:01:31	3:04:00	Wash	Hot Fill	2	46		46	

## Delete Data File

1. From the Data Log Screen highlight the Log to delete by touching the Log name.
2. Touching and holding a file name will allow you to select multiple files.
3. Touch **[Delete]**. After deletion a pop-up will confirm number of deleted files.



Locked Log Files will not be deleted.

## Settings

The Settings Screen allows the user to set or modify the systems settings.

**Figure 6-13**



## Language

Choose from eight languages: English, Spanish, French, German, Italian, Portuguese, Chinese and Japanese.

**Figure 6-14**

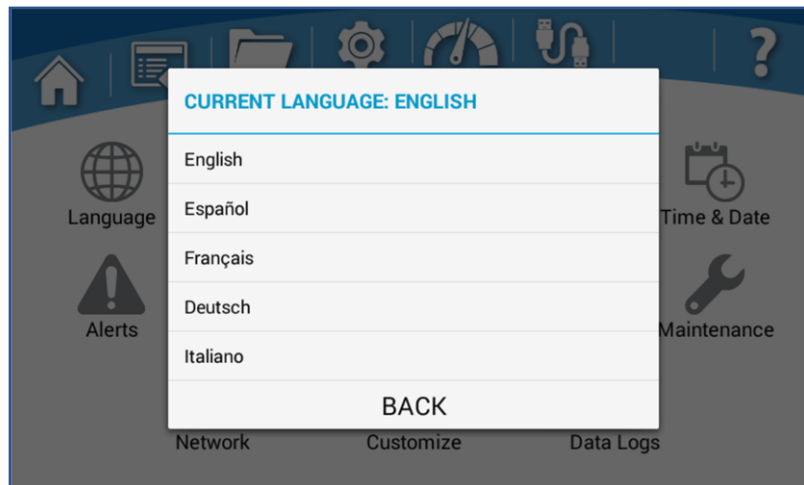

## Security

A four digit security code can be set that requires entry of a PIN to gain access to user-defined areas. The PIN will always be required to enter the Security screen.

- From the Settings Screen, touch the **Security** Icon, then enter the PIN (default is 1234) to gain access.
- Select the areas to be secured. See Fig. 6-15.
- To change the PIN, touch **[Set Code]**, enter new PIN two times, then touch **[Save]**.
- Once all changes are complete, to enable security, the **Security Toggle** in the bottom, right corner of the Security Screen must be set to **Enable**.
- Touch **[Back]**.

**Figure 6-15**

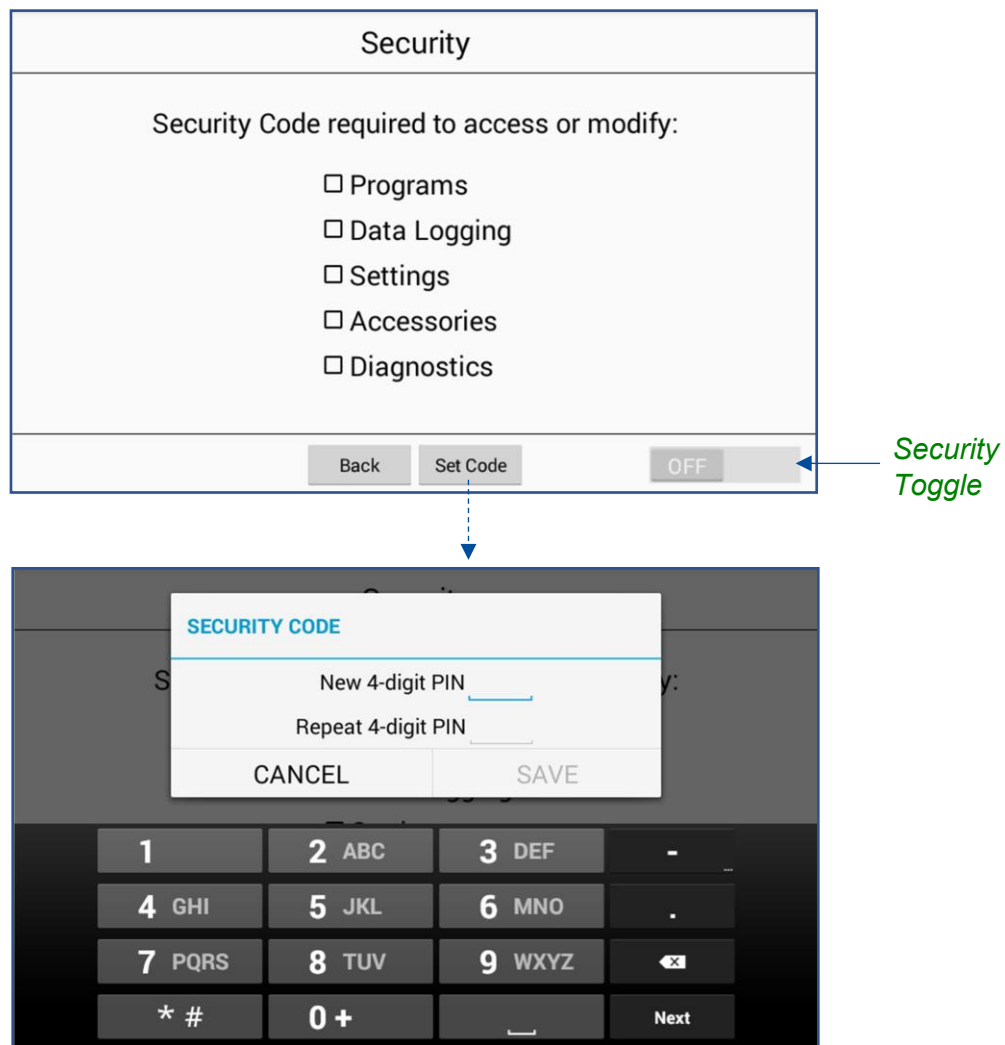

## Calibration - Offsets

Adjust the sensor readings to match a known standard(s).

*Current Reading (uncorrected)* = raw sensor reading with no offset applied.

*Offset* = Value that will be added to the Current Reading (uncorrected). The adjusted reading (uncorrected + offset) is the value reported on all screens outside of the Sensor Calibration screen.

1. To adjust the calibration offset, touch *Offset* field of the desired sensor. A pop-up will display, which allows an offset value to be adjusted for the sensor.
2. Using a known standard as reference, change the offset to match the value reported by the standard. For example, if the *Sump / Water Temp* reports an uncorrected reading of 35 °C, and the standard reference reports 36°C, change the offset to +1°C.

**Figure 6-16**

Sensor Calibration			
Offsets		Setpoints	
SENSOR NAME	CURRENT READING (UNCORRECTED)	OFFSET	LAST CAL. DATE
Sump / Water Temp	21° C	0° C	Aug 24, 2020
Conductivity Temp	21° C	0° C	Aug 24, 2020
Conductivity	6 µS	0 µS	Aug 24, 2020
Fill Level	-	0 %	Aug 24, 2020
Back			



When the *Offset* value is changed, the current date will be saved as the *Last Cal. Date*

Offset limits:

- Temperature = +/- 5 °C
- Conductivity = +/- 20 µS
- Fill Level = +/- 5%



## Time & Date

Reference Fig. 6-18. Use the Time and Date screen to choose Clock Format (12 or 24 hour), and then either manually Set the Time and Date, or enable Auto Update, which (if washer is connected to a valid Ethernet port) will auto update the time and date. With Auto Update the following settings need to be entered:

- Time Zone – Enter the Greenwich Mean Time (GMT) offset value for your location (integer value between -12 & +12).
- NTP server – Enter the “web address” (URL) of the NTP server (of your choice) that will provide clock synchronization data to the washer via the Ethernet connection. A common site is: time.nist.gov

**Figure 6-18**

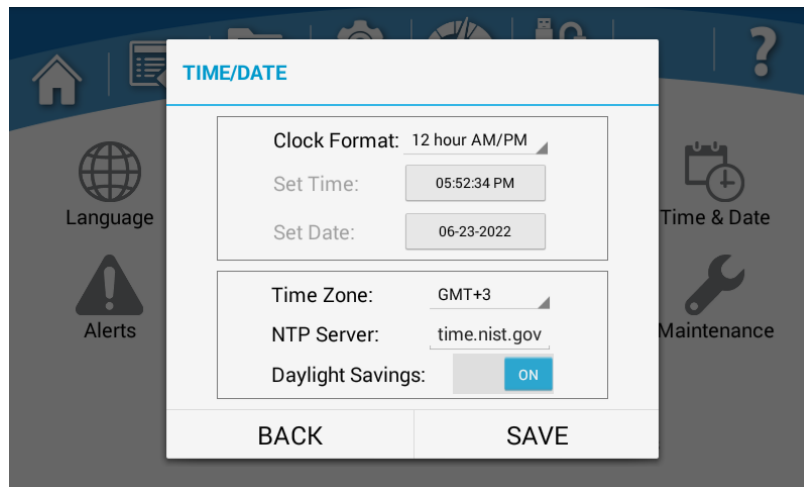

Finally, Daylight Savings (ON/OFF) can be enabled/disabled for areas observing Daylight Savings Time (DST).

## Alerts

If a valid network connection has been established and Network settings have been properly configured, (via the Network screen) alerts can be emailed to selected users, by entering the appropriate email address(es) and selecting the type of alerts to be sent to each email address. To enable e-mail alerts follow these instructions, and reference Fig. 6-19.

1. Each washer requires its own email address. Before proceeding, set up an email address for each washer. The e-mail account can be any free service (i.e. gmail.com, hotmail.com, etc) or a company's hosted domain (i.e. xyzlabs.com).
  2. Once the e-mail account(s) are set up, obtain the following information for each account (e-mail address):
    - SMTP Server
    - SMTP Username
    - SMTP Password
    - SMTP Port Number
    - Encrypted Connection
    - Here is an example (this information will not be correct for your e-mail account) set-up for fake e-mail account: Wash123@gmail.com
      - smtp.gmail.com
      - Wash123
      - cat@ndmouse457
      - 587
      - Enable
  3. From the Alerts Screen, touch the *Settings* icon. A pop-up will display. After entering the appropriate information in all fields, touch **[Save]**. The system will check valid formatting only. If one or more invalid entries are found the following message will appear: *Email Settings Error*. Correct the error and retry.
  4. If all the SMTP fields entered are valid, but the network connection is not working (or Ethernet cable is not connected) the following message will appear: *Email Settings Error – Network connection is not active*. Resolve the connectivity problem and retry.
- To add a user's email to receive e-mail alerts from the washer:
    - Press the *Add* icon at the lower right corner to add an email address.
    - Enter your e-mail address, touch **[Done]**.
  - To test the user's email:
    - Touch **[Test]** next to the desired e-mail address.
    - If all information is correctly entered, a test email from the washer will be sent.

Once the SMTP Settings (for the washer's e-mail address) have been correctly entered, and the notification e-mail address (e-mail address for who is getting notified) has been correctly entered and tested, the final step is to select the alerts to send the each e-mail address. Follow these instructions to select alerts.

1. Touch **[Alerts]** next to the email address. A pop-up displays the alert options:
  - Program Complete
  - Status Every 15 min / 30 min / 1 hour / 2 hour
  - All Alerts
  - Power Fail
2. Select the desired alerts. Only one Status alert frequency selection can be made. For example, if *Status Every 15 min* is selected, the other three frequency status alerts are inactive.
3. Touch **[OK]**.

**Figure 6-19**

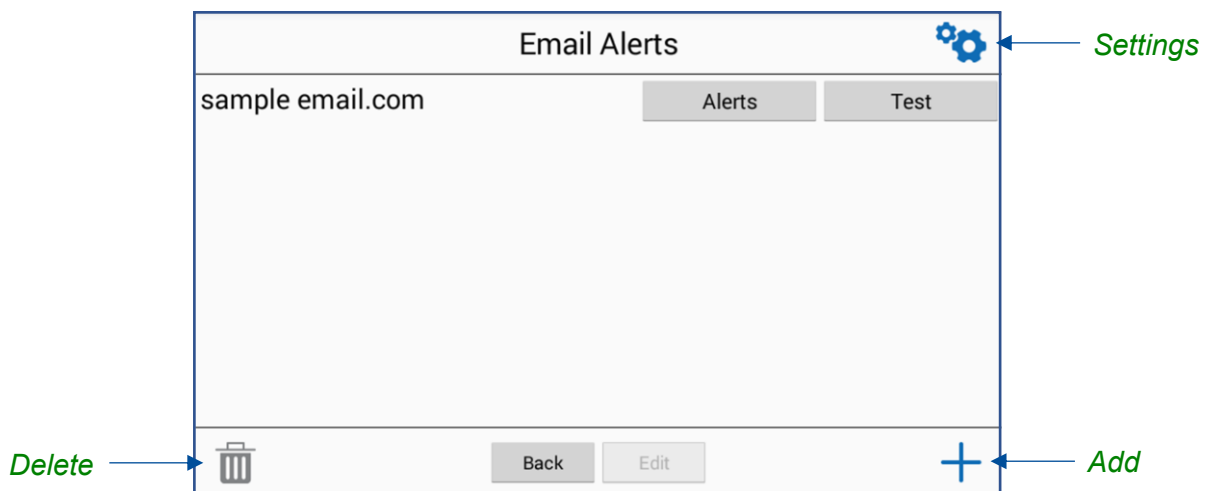

- To delete a user's email:
  - Touch the e-mail address to delete, it will highlight.
  - Touch the *Delete* icon in the bottom left corner of the screen.

## Display

This screen provides settings for the display screen functionality. Reference Fig. 6-20.

**Brightness Slider** – Adjust the display brightness by dragging the bar left/right.

**Touch Sounds** – Touching the toggle between ON & OFF will enable or disable audible beeps when the screen is touched.

**Screen Timeout Function** – If enabled, the screen will go to sleep (low power mode) when no screen touches have been detected for the allotted time (defined in the Screen Timeout dropdown menu). Touching the Screen Timeout Function toggle will toggle between ON & OFF.

**Screen Timeout** – This value can be set to 5, 10, 15, 30 min, and 1, 2, or 3 hours.

**Figure 6-20**

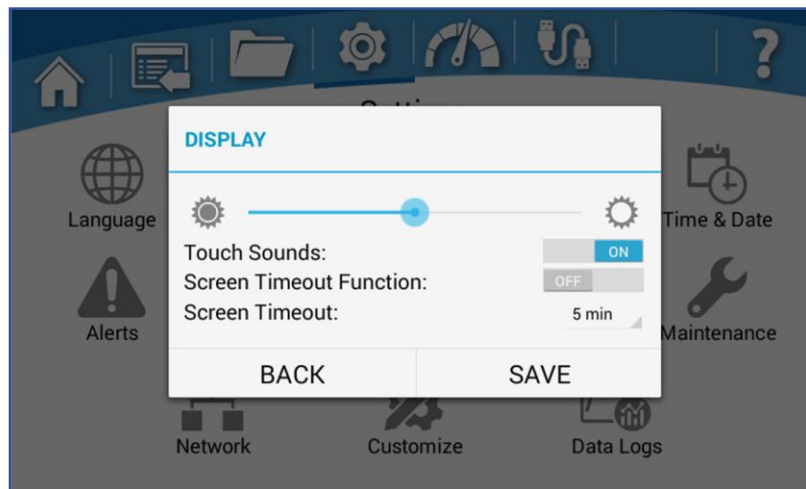

## Units

This screen allows the user to change the units of measure for various sensors.

- Touch the desired drop-down field, and make selection:
  - *Temperature* – Select the desired units of measure: °C or °F
  - *Length (Depth)* – Select the desired units of measure: millimeters or inches
- Once the selection is made, touch **[OK]**.

**Figure 6-21**

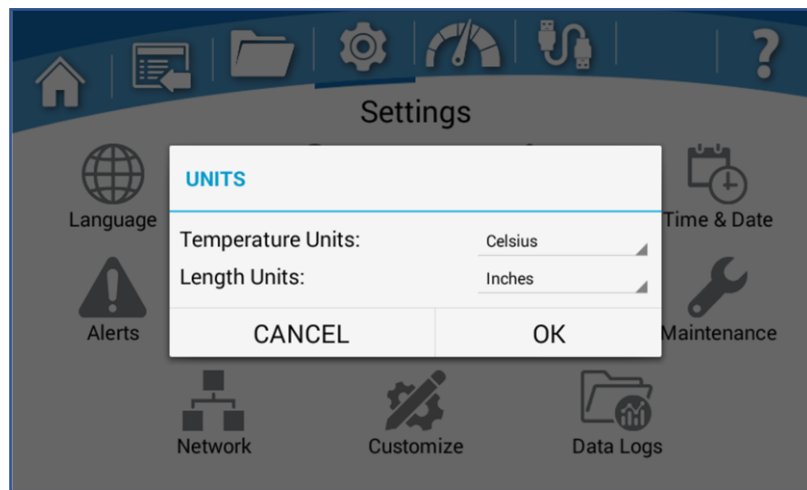

## Maintenance

View the Lifetime hours for the Wash Pump and Dry Blower. Change the reminder frequency, or reset, the Sump Screen Cleaning interval. Reference Fig. 6-22.

- From the Settings Screen, touch the *Maintenance* Icon to view the Lifetime hours of the wash pump and dry blower.
- Touch the *Clean Sump Screen* hours to modify the time interval for maintenance notifications. The default is 173 hours.
- Touch **[Reset]** to reset the Clean Sump Screen Reminder to zero (after the screen has been cleaned).

**Figure 6-22**

Maintenance			
<b>Lifetime Count:</b>			
Wash Pump:		2 Hours	
Drying Blower:		1 Hours	
<b>Reminders:</b>			
Clean Sump Screen every:	<input type="text" value="0"/>	Hours	0 Hours <input type="button" value="Reset"/>
Change HEPA Filter every:	<input type="text" value="1"/>	Hours	0 Hours <input type="button" value="Reset"/>
<input type="button" value="Back"/>			

## Network

Modify Network connection specifications, if an active ethernet connection has been established.

The most common setting for network connectivity via an Ethernet port is DHCP Enabled. This setting allows the facility's network to dynamically assign an IP address. Reference Fig. 6-23. Touch the toggle next to *DHCP Enabled* to change between enable / disable. When enabled, the remaining fields will be grayed out, as these will be assigned by the facility's network. If the field next to *IP Address* is populated with four sets of numbers (each separated by a period), and a green "Active connection detected" is displayed the washer has successfully received an IP address from the network. A red "No active connection detected" will be displayed if no connection is found. Please consult your IT department for additional assistance.

If a static IP address must be assigned by your facility's IT department, set the *DHCP Enabled* toggle to Disable. Contact your IT department for the appropriate information to enter the remaining fields.

Figure 6-23

The figure displays two screenshots of a network configuration interface. The top screenshot shows the 'Network' settings with 'DHCP Enabled' set to 'ON'. The fields for 'IP Address' (10.10.9.41), 'Subnet Mask' (255.255.255.255), and 'Default Gateway' (10.10.9.1) are populated. The 'Ethernet MAC Addr' is 2c:ab:33:68:20:a4. A green message 'Active connection detected' is shown. The 'Website Enabled' toggle is turned on. The bottom screenshot shows the 'Network' settings with 'DHCP Enabled' set to 'OFF'. The 'Default Gateway' is 10.10.75.1 and the 'Ethernet MAC Addr' is 2c:ab:33:6e:2a:a0. A green message 'Active connection detected' is shown. The 'Website Enabled' toggle is turned on, and other toggles like 'Upgrade Enabled', 'Logcat Enabled', and 'Control Enabled' are also visible.

By enabling 'Website Enabled', you will be able to remotely connect to the Washer. You will also be able to download data logs by selecting the one you want.

Once website access is enabled, to use these features, you must log onto the same network as the Glassware Washer. On your device, enter the web address shown in the IP address above. The IP address must be preceded by 'http://'. For example: `http://ipaddress`.

If you enable 'Upgrade Enabled', you will be able to upgrade the Washer using the Labconco website(see Software Update via Ethernet).

If 'Logcats Enabled' is selected, you can download the logcats. Once on the webpage the following screen will appear. Select 'Logcat' on the screen below and the file will download. This is a troubleshooting file used by Labconco service personnel to diagnose issues.

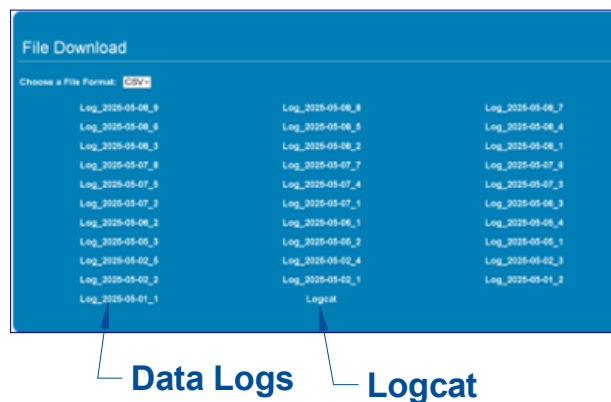

If 'Control Enabled' is enabled, you will be able to have limited control remotely from a computer or other device. From your device, you will not be able to enter alphanumeric values. You will be able to select buttons and the spinners. If security is turned on, you won't be able to use this feature. You will see the same screen as what is on the Washer.

## Customize

This screen allows the user to customize the washer's name. The name is utilized on all Data Logs, and on any e-mail Alerts (if enabled and connected via Ethernet cable).

If the optional Auto Detergent and/or Rinse Aid Dispense kits are installed, use the Customize Screen to customize the Auto Detergent and Rinse Aid names and abbreviations shown in the Program Screens. In addition, the maximum allowable dispense volumes of the Auto Detergent and Rinse Aid can be modified.

- From the Settings Screen, touch the *Customize* icon.

- To change the washer's name, touch the field next to *Device Name*, and change the name as desired (18 characters maximum). Touch **[OK]**.

If the Auto Detergent and/or Rinse Aid accessories are installed:

- To change the auto detergent or rinse aid name, touch the respective name field in the *Custom* column. Modify the name as desired (12 character maximum). Touch **[OK]**.
- To change the auto detergent or rinse aid abbreviation, touch the respective name field in the *Abbr.* column. Modify the abbreviation as desired (2 character maximum). Touch **[OK]**.



The auto detergent and rinse aid abbreviation is utilized in the Program Wizard to select the auto detergent or rinse aid source.



The auto detergent and rinse aid name field is utilized when displaying the respective accessory on the *Sensors* and *Accessories* Screens. And, on the Summary with Detail printed receipt to identify which detergent/rinse aid was dispensed (if the optional printer accessory is installed).

- In the Program Wizard the auto detergent and rinse-aid dispense volumes are selectable in 1 mL increments up to a maximum of 130 mL. To adjust this maximum allowable value, touch the respective field in the *Max Disp.* column.
- A pop-up will appear. Swipe up/down to adjust the max allowable dispense volume in 1 mL increments. The limits to this adjustment are:
  - Auto Detergent: 150 mL
  - Rinse Aid: 150 mL
- Once all the changes are complete. Touch **[Save]**.

The Customize Screen is shown for reference in Fig. 6-24 on the following page.

**Figure 6-24**

Device Name: Labconco Washer <span style="float: right;">15/18</span>			
Auto Dispense Names			
ADDITIVE	CUSTOM	ABBR.	MAX DISP.
Detergent 1	Detergent 1	D1	40 mL
Rinse Aid 1	Rinse Aid 1	R1	40 mL
<input type="button" value="Back"/> <input type="button" value="Save"/>			

## Data Logs

Modify the Data Acquisition Rate and the Log File Deletion settings.

- Touch the drop-down menu next to *Data Acquisition Rate*, and modify the rate among the intervals available: 10sec, 30sec, 60sec, 5min or 10min. Touch [OK].
- Touch the drop-down menu next to *Log File Deletion*, and modify the deletion interval among the selections available: Never, 1 week, 1 month, 3 months, 6 months, 1 year. Touch [OK].



The system default for Log File Deletion is Never.

Figure 6-25

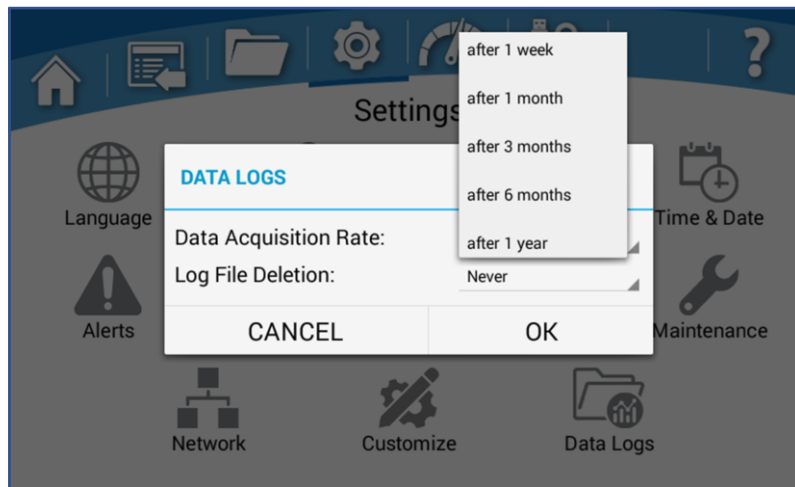

## Sensors

This screen contains a list of all the sensors currently installed on the Glassware Washer. The Sensors Screen displays the current sensor reading (including offsets) in the selected unit of measure. This screen is for viewing only (there are no selectable fields). Reference Fig. 6-26.

NAME	VALUE
Sump / Water Temp	24° C
Conductivity Temp	29° C
Conductivity	3 µS
Fill Level	0.00 mm
Detergent 1	-
Rinse Aid 1	-
Overflow	-
Door	-

Figure 6-26

## Accessories

This screen contains the list of all accessories currently installed on the Glassware Washer. The screen displays the state (Enabled/Disabled) of each accessory. The Status can be switched ON or OFF to Enable or Disable the accessory. Accessories can be turned off, for instance if the washer is not connected to pure water, the Pure Water can be disabled. If the pure water connection is pressurized the Pure Water Pump can be turned off to increase the flow rate of pure water into the washer. Reference Fig. 6-27.

The following accessories may be displayed and enabled/disabled from the Accessories Screen:

- Pure (DI) Water Pump
- Pure (DI) Water
- Detergent 1
- Rinse Aid 1
- Conductivity
- LED Light
- Rinse Aid Cup

To enable/disable an accessory, touch the toggle to change between ON/OFF. See Fig. 6-27.

**Figure 6-27**

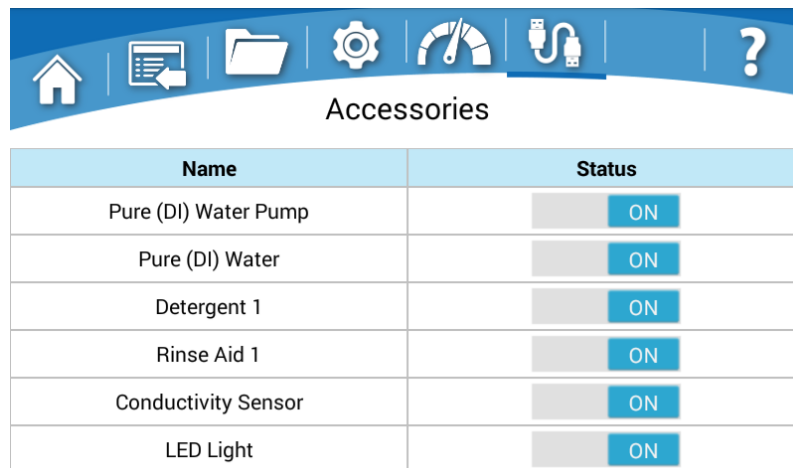

The screenshot shows the 'Accessories' screen with a navigation bar at the top containing icons for Home, List, Folder, Settings, Gauge, USB, and Help. Below the navigation bar is a table with two columns: 'Name' and 'Status'. The table lists six accessories, all of which are currently turned ON.

Name	Status
Pure (DI) Water Pump	ON
Pure (DI) Water	ON
Detergent 1	ON
Rinse Aid 1	ON
Conductivity Sensor	ON
LED Light	ON

## Help

The Help screen contains several useful submenu icons. The sub-menus are described briefly below. Reference Fig. 6-28.

**About Screen** – Provides unit specific information (Catalog Number, Serial Number, Software Version). Software updates via USB or Ethernet can be performed from the About page.

**Diagnostics** – Used to test washer operation/components after installation or should a problem occur.

**Resources** – Provides QR codes for direct links to the Labconco Website for documentation or accessory/consumable information.

**Backup/Restore** – Allows the user to export custom programs and/or data logs, as well as import custom programs.

**Figure 6-28**



## About

Displays Operating System information such as the software version, the Catalog Number and Serial Number. System updates via USB can be performed from the About screen. Reference Fig. 6-29.

**Figure 6-29**

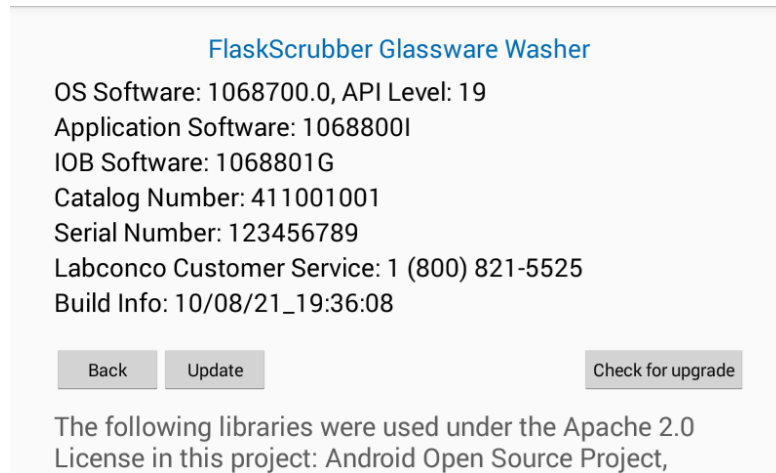

## Software Update via USB Thumbdrive

To update the software via USB, you must first download the latest version, available at Labconco.com to a USB thumbdrive.

- Insert the flash drive into the USB port located under the display screen.
- Once the system recognizes the flash drive, touch **[OK]**.
- From the **About** screen, touch **[Update]**.
- Select the Bundle file (BND) with the latest revision of software
- The software will automatically copy the software bundle, unpack it and install the software update. The system will notify you when the upload is complete and successful.
- Remove the thumbdrive from the USB port.

## Software Update via the Ethernet

To update the software via the ethernet, you must first have an active connection. Refer to Figure 6-30.

- From the **About** screen, touch **[Check for Updates]**.
- If available the **Upgrade Available** screen will display and allow you to ignore, postpone or update now.
- Pressing the **Release Notes** will allow you to review the changes
- If available and you would like to update, select **[Update Now]**.
- 

## Automatic Update Notification

To Program the washer to notify you if Upgrades are available, the system must have a valid ethernet connection and the latest software installed.

- From the **About** screen, touch **[Check for Updates]**.
- At the **Upgrade** screen touch **[Configure]** and select **Automatically check for updates** and **[OK]**.

Once programed the Upgrade Available screen will pop up when new software becomes available.

**Figure 6-30**

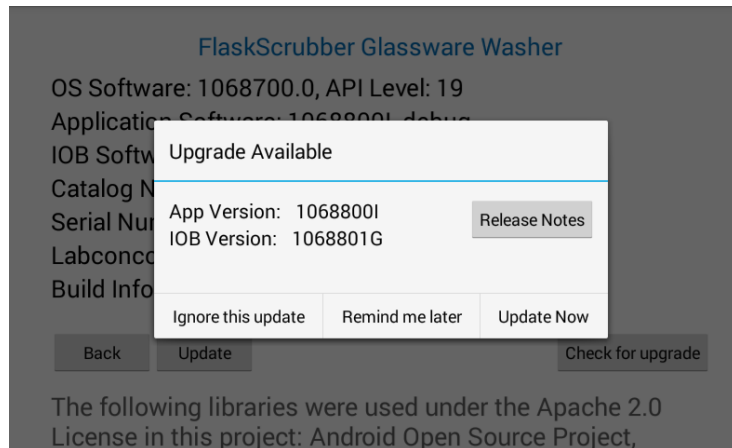

## Diagnostics

The Diagnostics Screen is used to test washer operation/components after installation or should a problem occur. Each electrical component can be turned on individually, or a single operation can be tested, such as Fill or Drain. Reference Fig. 6-30.

- FILL ALL THE WAY: Fills to the set point level via the hot water supply
- FILL ALL THE WAY PURE: Fills to the set point level via the Pure water supply
- DRAIN ALL THE WAY: Drains washer for 3 minutes (drain valve & drain pump)
- WASH PUMP: Operates the Wash Pump for 10 seconds
- HEATER 1: Operates Heater 1 for 10 seconds
- HEATER 2&3: Operates Heaters 2&3 for 10 seconds (3 Phase units only)
- DRAIN VALVE: Operates Drain Valve for 10 seconds
- DRAIN PUMP: Operates Drain Pump for 10 seconds
- PRINTER TEST: Test Printer function (if installed).
- Manual/Auto Run Tests: Automatically runs a diagnostic and checks the amperage draw on all low voltage components below.
  - FILL VALVE (HOT TAP): Operates Hot Water Fill Valve for 10 seconds
  - DI VALVE (PURE): Operates Pure Water Fill Valve for 10 seconds
  - DI PUMP (PURE): Operates Pure Water Pump for 10 seconds
  - DETERGENT CUP: Operates the Detergent Cup (recommend closing Cup before running – after test the Door Detergent Cup should be open)
  - DRY BLOWER 1: Operates Dry Blower for 10 seconds
  - ELECTRONIC COOLING FAN: Operates Fan for 10 seconds
  - LED LIGHT: Operates Door Window Light for 10 seconds
  - DETERGENT PUMP 1: Operates Auto Detergent dispense pump for 30 seconds

- RINSE AID PUMP 1: Operates Auto Rinse Aid dispense pump for 31 seconds
- DOOR LATCH: Opens the Door Latch

**Figure 6-31**

Diagnostics	
COMPONENT	TEST RESULT
<b>Manual Only Run Tests</b>	
▶ FILL ALL-THE-WAY	
▶ PURE FILL ALL-THE-WAY	
▶ DRAIN ALL-THE-WAY	
▶ WASH PUMP 1	
▶ HEATER 1	
▶ DRAIN VALVE	

## Resources

The Resources Screen provides QR codes for a direct link to the Labconco website for documentation and/or accessory and consumable information. Reference Fig. 6-32.

- From the Help Screen, touch **Resources**.
- Using a smartphone with camera, scan the desired QR code and you will be directed to the appropriate information on labconco.com.

**Figure 6-32**



## Backup and Restore

Allows for the import/export of custom programs and/or data logs via USB thumbdrive. Either export user-created programs and/or data log files, or import user-created programs from another washer. Reference Fig. 6-33.

- Insert thumbdrive in the USB port below display.
- Once system recognizes the USB thumb drive, touch **[OK]**.
- From the Help Screen, touch *Backup/Restore*.
- Select an action: *Export* or *Import*.
  - If Export selected, choose to export either *Log Files* or *User Programs*, or both can be selected.
- Touch **[OK]**.
- If exporting, a progress pop-up will display, and notification provided when export is complete.
- If importing, a progress pop-up will display, and notification provided when import is complete.
  - If the thumbdrive in the USB port does not contain a proper User Program backup file, an error message will be displayed.

**Figure 6-33**

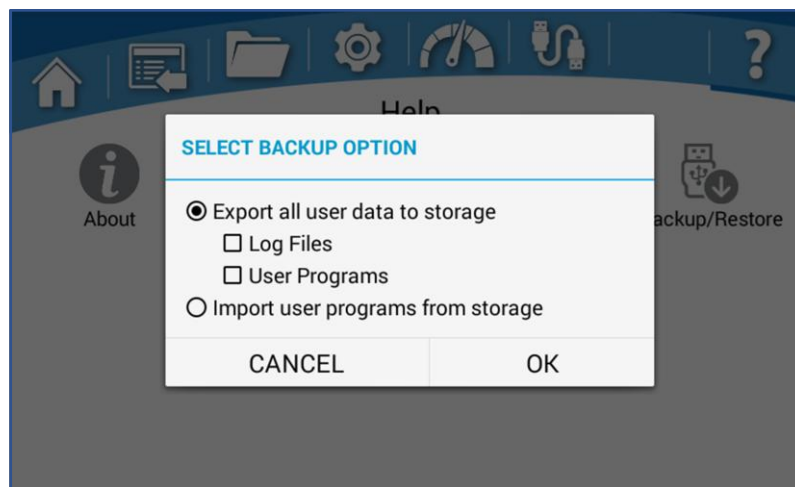

## Notification

The Notification Screen allows the user to see all alerts that were encountered. The alerts can be exported as CSV or PDF file format with a thumb drive.

Notification History	
Description	Recent Top ▼
⚠ Program Canceled	May 15, 2025 12:32 PM
⚠ Program Canceled	May 15, 2025 12:04 PM
⚠ Low Temp Wash/Rinse	May 15, 2025 12:03 PM
⚠ Door Open	May 15, 2025 10:00 AM
⚠ Door Open	May 15, 2025 09:59 AM
⚠ Door Open	May 15, 2025 09:59 AM
⚠ Door Open	May 15, 2025 09:29 AM
⚠ Door Open	May 14, 2025 01:52 PM

Back    Export USB

Notification History	
Description	Recent Top ▼
⚠ Program Canceled	May 15, 2025 12:32 PM
⚠ Program Canceled	May 15, 2025 12:04 PM
⚠ Low Temp Wash/Rinse	May 15, 2025 12:03 PM
⚠ Door Open	May 15, 2025 10:00 AM
⚠ Door Open	May 15, 2025 09:59 AM
⚠ Door Open	May 15, 2025 09:59 AM
⚠ Door Open	May 15, 2025 09:29 AM
⚠ Door Open	May 14, 2025 01:52 PM

EXPORT

CSV

PDF

CANCEL    OK

Back    Export USB

## 7: Using Your Glassware Washer

---

This section details the functional features and proper techniques for safely and efficiently using the Glassware Washer.

### Washer Rack Configuration

The FlaskScrubber Vantage Series Glassware Washer is equipped with the lower spindle rack. In addition to the standard rack configuration of each model, many optional racks and inserts are available to customize your washer to best suit your needs. For a complete list of available rack accessories, refer to [Section 9: Accessories & Consumables](#).



A FlaskScrubber Vantage Series Glassware Washer can accommodate the standard racks by replacing the lower rack and adding an upper rack with slides.

### FlaskScrubber Vantage Series Spindle Rack

The FlaskScrubber Vantage Series Glassware Washer lower spindle rack with glassware holders is designed for narrow-necked glassware such as volumetric flasks, Erlenmeyer flasks, graduated cylinders, Kjeldahl flasks, test tubes, BOD bottles and digestion tubes.

For versatility, two sizes of spindles are provided with the washer: (36) 0.25" (6.35 mm) OD and (10) 0.125" (3.18mm) OD spindles. Several optional inserts can be placed in the rack to support various configurations of glassware. See [Section 9: Accessories & Consumables](#) for available options. Each spindle, or spindle arm, can be removed with the supplied wrench and replaced with plugs included with the washer. The spindle arms can be angled to enable washing long items, up to 24", such as graduated cylinders. Optional top racks are available for the FlaskScrubber Vantage Series to expand the washer's capacity to accommodate many types of glassware. An Upper Spindle Rack with 36 spindles and slides (Catalog Number 4668500) is available.

# Loading Glassware into the Spindle Rack

Glassware Holders are supplied with each Spindle Rack. These holders enable you to position glassware directly over the spindles. See Fig. 7-1.

Figure 7-1

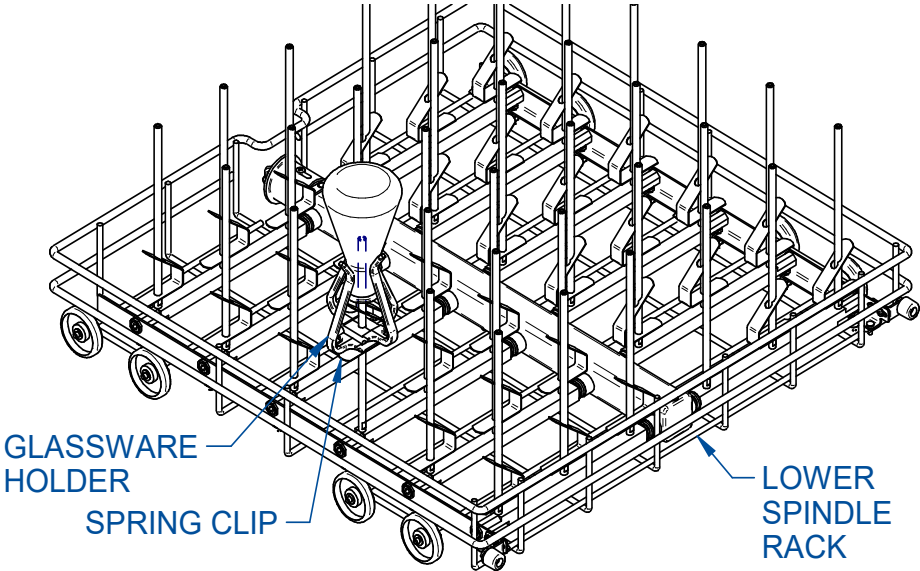

## Loading a Glassware Holder

- Press the glassware into the holder; the fingers should spring out and grip the glassware.



It is normal for the clamps to deform if large glassware is inserted into the Holder and the washer is operated at high temperature. Do not use with glassware over 2.5 inches in diameter as damage to holder may occur.

- To reduce the possibility of trapping water in the glassware, the horizontal leg of the spring clip should be positioned on the bottom side of the holder.
- The holder may be raised or lowered by squeezing the spring clip on the bottom of the holder and then sliding the holder up or down. The horizontal leg of the spring clip should be positioned on the bottom side of the holder.
- For best results, do not allow the glassware to rest directly on top of the spindle.

Glassware should be loaded so that it does not touch during a wash cycle. To reduce noise and glass breakage, be certain that glassware is secure.

## Removing or Adjusting the Optional Upper Rack

The optional upper rack is easily raised or lowered to accommodate different size glassware. The optional upper rack may also be removed from the Glassware Washer to facilitate loading the rack outside the washer or to allow very tall glassware to be loaded and washed on the lower rack. See Fig. 7-2.

### Remove the upper rack

- Slide the upper rack all the way out of the washer.
- Grasp the handles on each side of the rack, lift one side of the rack while putting slight pressure toward the opposite side of the rack. Once the rack clears the slide bracket slots, raise the rack off the opposite slide.

### Replace the upper rack

- The upper rack can be replaced by pulling each slide all the way out of the washer. Hold the rack by the handles above the slides making sure the rack's water inlet adapter is facing to the back of the washer, lower one side of the rack into the top position of the slide bracket rack seats. Once the rack is seated on one side, continue to lower the opposite side of the rack down to rest in the slide bracket seat.
- The rack can then be moved to the lower position if required.

### Raise the upper rack height

- To raise the rack to the upper position, slide the upper rack all the way out.
- Grasp the handle on one side of the rack, lift the rack straight up while letting the rack bracket slots guide the rack to the top of the slots and then out to the upper rack bracket pin seats. Repeat this process on the opposite side. Make sure the rack pins are set securely in all four upper rack bracket pin seats.

### Lower the upper rack height

- To move the rack to the lower position, slide the upper rack all the way out.
- Grasp the handle on one side of the rack, lift the rack straight up and then back while letting the rack bracket slots guide the rack to the lower rack bracket pin seats. Repeat this process on the opposite side. Make sure the rack pins are set securely in all four lower rack bracket pin seats.

**Figure 7-2**

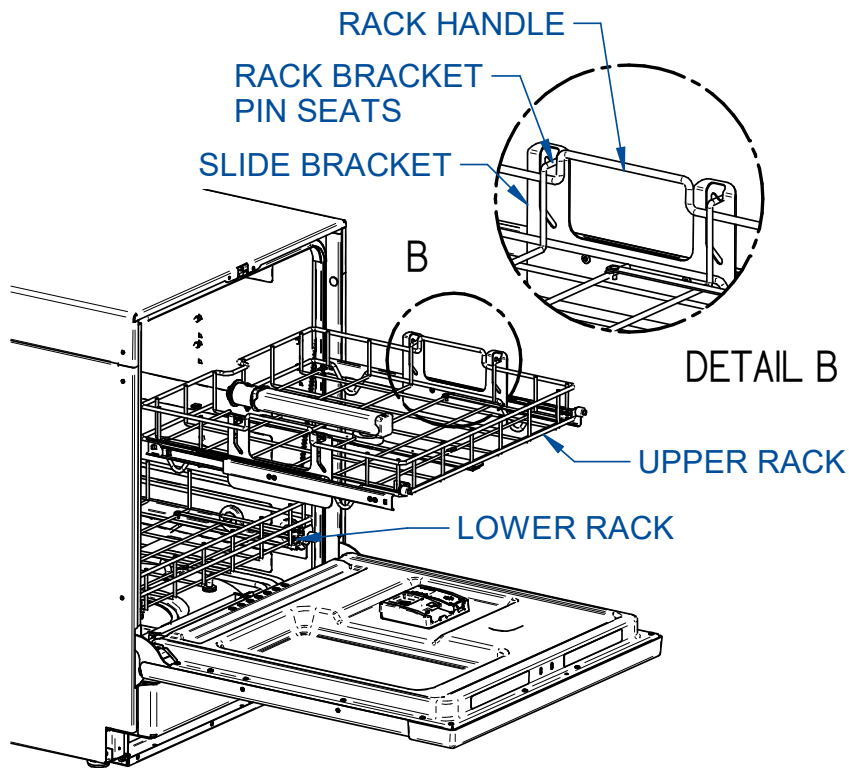

## Liquid Detergent and Neutralizing Acid Rinse Dispense Systems

Your washer is equipped with the Automatic Detergent and Rinse Aid Dispense Systems. Detergent and rinse aid can be dispensed from containers stored in the side cabinet. There are two Factory Programs, Intense and Extreme, that are set to dispense from the automatic dispense systems. If you choose to use the detergent dispenser (Soap Cup) and rinse aid reservoir in the door, with either of these programs a new program would need to be created to dispense from the Soap Cup. Likewise, if you wish to use the automatic dispense system with any of the other factory programs a new program will need to be created by copying the desired program and editing the dispense settings. Refer to [Section 5: Program](#).

When liquid detergent and neutralizing acid rinse are first added to their dispense containers or if the containers are permitted to empty completely, the dispense pumps and supply tubing must be purged of air. If not done, a wash cycle could be run with insufficient detergent or neutralizing acid rinse. When refilling the containers follow this same procedure except it is not necessary to purge the system if the containers are not permitted to empty completely.

### To fill or purge the auto dispense systems

1. Open the equipment compartment on the left side of the Washer by pushing on the right side of the cabinet door panel. The door panel will pop open.
2. The larger storage container inside the cabinet is for LabSolutions Liquid Detergent and the smaller container is for LabSolutions Neutralizing Acid Rinse.
  - a. Detergent Container
    - i. Unscrew and remove the cap from the container.
    - ii. Remove the plug with the tube and float switch attached.
    - iii. Replace the empty container with a full container of LabSolutions Liquid Detergent (Labconco P/N 4522000) or refill the old container.
  - b. Acid Neutralizing Container
    - i. Unscrew and remove the cap from the container.
    - ii. Pull the drawtube out of the container.
    - iii. Remove the plug with the float switch attached.
    - iv. Replace the empty container with a full container of LabSolutions Neutralizing Acid Rinse (Labconco P/N 4422200) or refill the container.
    - v. Install the level switch and then the drawtube into the full container and reattach the cap.
3. To purge the system tubing of air and fill (or refill) with detergent and neutralizing acid rinse, go to the diagnostics screen run a diagnostics test on the detergent and rinse aid pumps.

## Detergent Dispenser (Soap Cup)

Your Glassware Washer is equipped with a detergent dispenser (also referred to as a Soap Cup) inside the door, which contains a Main Wash Cavity and a Neutralizing Solution (Rinse-Aid) Reservoir as shown in Fig. 7-3. In addition, the dispenser door provides a depression (Pre-Wash Detergent Cavity) where detergent may be added for use during the first Wash of the cycle.

The Factory Programs included with the FlaskScrubber Vantage Series Glassware Washer are set to dispense from the Automatic Dispense System. If you should choose to use the detergent cup and rinse aid reservoir in the door, a new program would need to be created to dispense from the Detergent cup. See in [Section 5: Program](#).

**Figure 7-3**

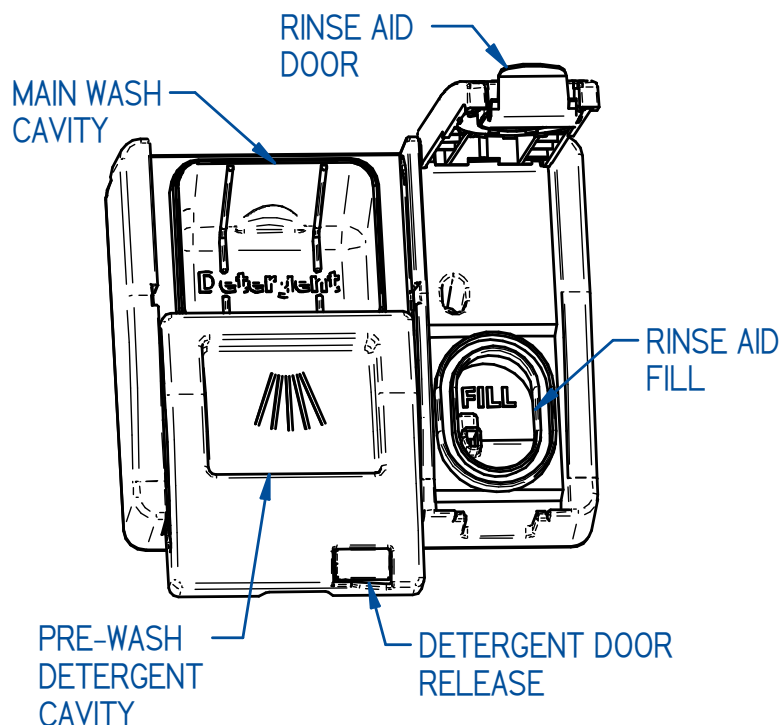

### Adding Detergent

Low-foaming powder or liquid detergent formulated for labware washers, in conjunction with adequate hot water, is essential for clean glassware. Labconco LabSolutions Detergents are recommended. See [Section 9: Accessories & Consumables](#) for ordering information. Using detergents sparingly, too much detergent, particularly with softened water may cause etching of the glassware. This appears as a permanent cloudy film on the glassware.

When running a customized program where you have selected Detergent to dispense from the door Detergent Dispenser, fill the Main Wash Cavity (See Fig. 7-3) of the Detergent Dispenser with approximately 25g of Lab Solutions powered detergent or 20ml of liquid detergent if the water hardness grains per gallon (GPG) of your water measures 0-4 GPG (soft water). Fill the detergent cavity completely with powdered detergent or 40ml liquid detergent if your water measures 4 GPG or higher (medium to hard water). Use these recommendations as guidelines, adjust the amount of detergent used based on actual results of your wash cycle. If the hardness of the water is unknown, begin with the lower amounts of detergent and rinse aids.



To open the detergent dispenser, gently press the white button located on the detergent cup door.

The door may break if it is forced upward or perpendicular to the door.

Store detergent in a cool, dry place. Immediately replace the detergent container lid after dispensing. If lumps develop due to exposure to moisture, discard the detergent according to local regulations.

### Adding Neutralizing Acid

When running a customized program where you have selected Rinse Aid to dispense from the door Detergent Dispenser, a mild or weak acid rinse aid may be dispensed from the neutralizing solution port to neutralize the detergent alkalinity. Labconco LabSolutions Neutralizing Acid Rinse is recommended. See [Section 9: Accessories & Consumables](#) for ordering information. The timing and amount (0 to 6 ml) of acid rinse dispensed can be programmed to open during any one of eight programmable rinse segments by creating customized programs. The dispenser holds approximately 170 ml and should be replenished as needed. An alert will be displayed when Rinse Aid level is low and needs refilled. To fill the neutralizing acid dispenser, refer to the Fig. 7-3 above and follow the instructions below.

1. Raise the Rinse Aid Door on the Detergent Dispenser.
2. Fill the cavity with LabSolutions Neutralizing Acid Rinse (Catalog 4522200) until the level of the liquid rises and is visible in the port. Close the door.

## Safety Reminders

Review the following safety reminders regularly with all personnel working with the Glassware Washer. Failure to abide by these precautions may result in damage to the washer, your glassware or bodily harm to the user.



**Do not use combustible solvents in the Glassware Washer. If soiled glassware contains flammable compounds, rinse the glassware thoroughly prior to placing the glassware into the washer. Heaters in the washer are very hot and could ignite flammable solvents.**



**Petroleum based compounds and some strong acids may degrade certain internal washer components. Always thoroughly rinse all glassware before placing in the Washer.**



**Pay attention to the warning labels on the Glassware Washer door. They warn of hot steam and/or surfaces, and flammable solvents are prohibited. See Fig. 7-4.**

Figure 7-4

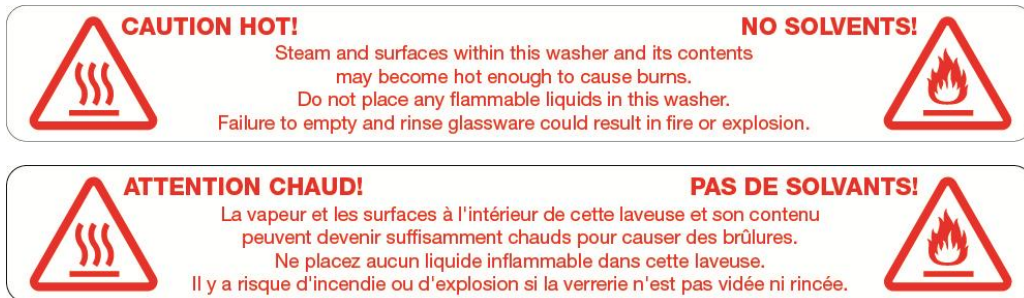

**Do NOT use foaming detergents, or any soap, surfactant or detergent not specially formulated for use in glassware washers. Failure to abide by this specification may result in water/detergent over spilling the door seal and damaging the washer and/or the facility and is not covered by warranty.**

## Selecting and Starting a Wash Cycle

Before selecting a program, refer to [Appendix C: Glassware Washer Specifications](#) for complete details on the factory programs and the options available for customizing programs. After you have loaded the washer, placed detergent and neutralizing acid or rinse aid in the dispenser, follow the instructions below to start the cycle.



The washer has the capability to wash glassware at high temperatures. If plasticware is being washed, use care when selecting high-heat programs.

Figure 7-5



1. Close the washer door and select the desired program by touching the *Program Selection Dropdown* (See Fig. 7-5). Touch the desired program name. The display will return to the Home Screen showing the program segments, maximum temperature per segment and Estimated Run Time.
2. Touch the *Run* icon, a pop-up will ask for confirmation to start the selected program at the programmed data rate and time delay. A time delay can be added or modified by touching the Time Delay field on the pop-up. Once the parameters are correct, touch **[OK]** to begin the cycle.
3. The program will run through the cycle segments as indicated by the *Progress Indicator*. As each segment is successfully completed the progress pie will change to a blue check mark. If any non-fatal alarm(s) occurs during the segment, a yellow check mark will be displayed. Touch the yellow check mark to display the alarm. If a Fatal Alarm occurs during the segment or the program is cancelled, the washer will drain the tank and end the cycle, a red **X** will be displayed. Touch the red **X** to display the alarm that occurred.
4. Once the cycle is complete, a Program Complete pop-up will be displayed.

## Interrupting a Wash Cycle/Open Door

To temporarily pause a wash cycle, touch the *Pause* Icon and select [OK] to confirm. Reference Fig. 7-6. The wash cycle will stop. Press the Open button to open the door.



**When opening the door, if the internal temperature is greater than 50°C, a warning will display which requires confirmation before opening the door. Use extreme caution, open the door slowly, hot steam will rise out of the washer which could cause injury.**

**Lors de l'ouverture de la porte, si la température interne est supérieure à 50°C, un avertissement s'affichera qui demandera la confirmation que vous voulez ouvrir la porte. Faites preuve d'une extrême prudence, ouvrez la porte lentement, la vapeur chaude s'élèvera de la laveuse qui pourrait causer des blessures.**

If you press open while the cycle is running, the washer will prompt for confirmation to pause the cycle. If confirmed, there will be a 7 second delay before the door unlocks.

To resume the wash cycle, close the washer door until latched. Touch the *Start* Icon and then confirm by touching [OK]. If the water temperature is greater than 50°C the washer may pause for up to 2-1/2 minutes to equalize the internal temperature, after which the cycle will resume the interrupted segment.

The wash cycle can be terminated at any time by touching the *Cancel* Icon, and then touching [OK] on the confirmation pop-up.

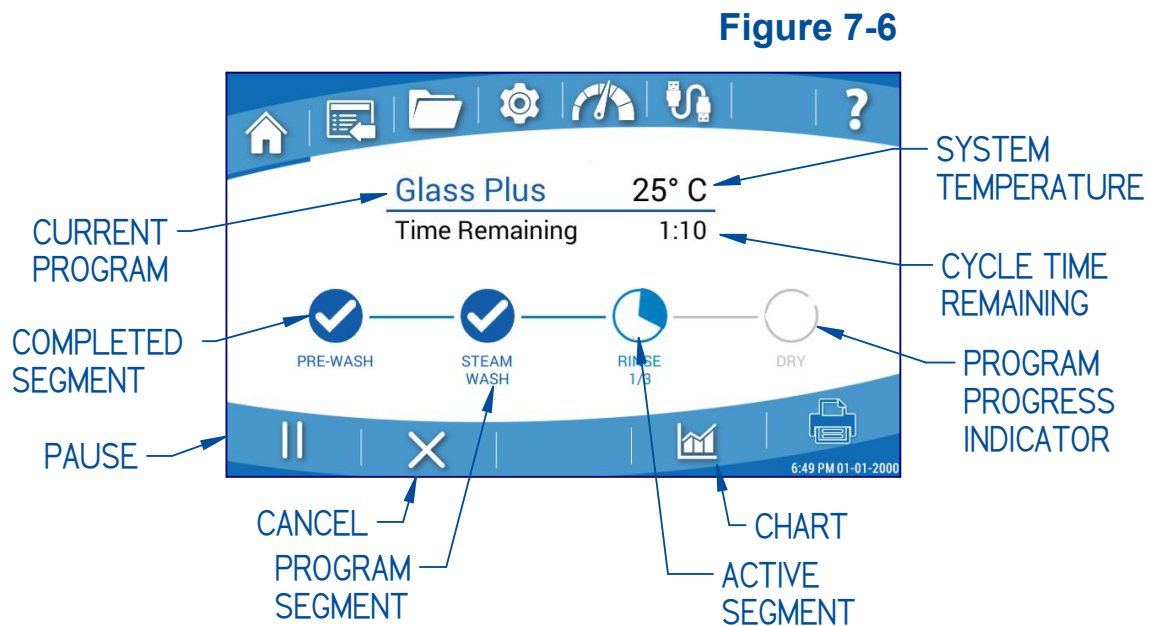

## Alarms

Throughout a program cycle there are several abnormal events that could occur. The washer is programmed to monitor these occurrences and provide an alarm to alert the user. Information is displayed to identify the alarm situation, which may be Fatal or Non-Fatal to the running program. See Table 7-1 for a list of all Alarm Codes and their description. Fatal alarms during a cycle will drain the washer, end the program and display a red **X** on the segment in which the error occurred. Non-Fatal alarms will allow the program to proceed. The display will show a yellow check mark at any complete segment in which a non-fatal alarm occurred. Touching the red **X** or yellow check will display alarm details and the time of occurrence.

**Table 7-1**

ALARM CODE	ALARM DESCRIPTION	CONDITION	RESPONSE
A1	LOW AUTO RINSE AID 1	Low Rinse Aid in Auto Dispense *	NON-FATAL
CS	CONDUCTIVITY FAILED	Conductivity sensor is not responding**	NON-FATAL
D1	LOW DETERGENT 1	Low Detergent in Auto Dispense *	NON-FATAL
DF	DRAIN FAIL	Pressure Sensor did not reach 0 during drain	FATAL
DL^	DOOR LATCH FAIL	Door unlatched during cycle	FATAL
DO	DOOR OPEN	Door not fully closed	FATAL
FF	FILL FAIL	Low Water after allotted fill time expires	FATAL
FI	FIRMWARE	Firmware Unresponsive	NON-FATAL
HW^	HIGH WATER	Fill Level too high during segment	FATAL
LT	LOW TEMP	Temperature Set Point not achieved	FATAL
NW	NO WATER	No or Low Water during segment	FATAL
OV^	OVERFLOW	Water detected in base	FATAL
PC	PROGRAM CANCELED	User initiated Program Cancel	FATAL
PF	POWER FAIL	Power Loss occurred	NON-FATAL
PP	PROGRAM PAUSED	User initiated Program Pause	NON-FATAL
RA	RINSE AID LOW D-CUP	Low Rinse Aid in Detergent Dispense Cup	NON-FATAL
SS	STEP SKIPPED	User initiated Segment Skip	NON-FATAL
TA	HIGH TEMP ALARM	Temperature sensor reading above 110C	FATAL
TS^	TEMP SENSOR	Temp Sensor error or disconnected	FATAL
WQ	CLEANPOINT FAIL	Clean water quality/conductivity not reached**	NON-FATAL
WR	CLEANPOINT PASS	Clean water quality/conductivity reached. **	NON-FATAL
FV	FILL VALVE FAILURE	Water indicated in sump while inactive	DRAIN SUMP

\* Only on models with optional Auto Dispense or Rinse-Aid Dispense accessory installed.

\*\* If equipped.

^ Fatal Alarm that requires a power reset to clear alarm once issue is resolved

## Completing the Wash Cycle

The wash cycle can be terminated at any time by pressing the *Cancel* Icon and confirming the cancelation. The washer will drain and end the cycle. The progress bar will display a red **X** at the segment in which the program was cancelled.

If the cycle is completed with no interruptions or alarms, the progress bar will display blue checks at each segment, and a Program Complete pop-up will display until acknowledged.

If Auto-Unlock was enabled in the program, once the internal temperature is below 50°C the door latch will open to allow the washer to vent and assist drying.

## 8: Maintaining Your Glassware Washer

---

This section details the maintenance required for optimal performance and operation of the Glassware Washer.

Under normal operation, your Glassware Washer will require little routine maintenance to keep it functioning properly.

### Maintenance Safety Precautions



The following safety precautions must be followed by all personnel maintaining the equipment.

- Wear safety glasses, and/or additional eye and face protection as required by your Health & Safety Department.
- Wear gloves, and/or additional skin protection as required by safety instructions for cleaning/disinfecting chemicals used. Consult your Health & Safety Department for additional skin protection requirements.
- No loose-fitting clothes
- Wear close-toed shoes
- Although the service operations detailed in this section do not involve access to areas of the product with moving or electrical parts, should you remove any panels that expose moving or electrical parts, you must follow these instructions before doing so:
  - Disconnect main power cord or electrical service connection
  - Never touch moving parts such as fan blades or blower wheels.



### Maintaining the Stainless Steel Interior

The interior of the Glassware Washer is type 304 stainless steel. Never use metal scouring pads on the stainless steel interior. Metal scouring pads can scratch or leave ferrous particulate that will rust.

To maintain the appearance and quality of the stainless steel interior, perform the following tasks as needed:

- Wipe the outer edges on the inside door panel to remove particles and residue that occur during loading.

- Use a sponge sprinkled with non-abrasive **stainless steel cleaner** to gently wipe the washer tank and door to remove surface discoloration caused by exposure to halogenated compounds or steel parts. In some cases, the finish may be slightly dulled by this action.

If your water has a high mineral content, film or spots may develop on the washer interior. If the procedures listed above do not eliminate the film or spots, you may run your washer through the Clean Washer Cycle below.

### Clean Washer Cycle

1. Remove all glassware from the washer.
2. Pour one cup of 4-8% acetic acid or white vinegar into the bottom of the washer tank.
3. Select and run the Clean Washer Program.

### Maintaining the Air Gap in Drain

If the installation includes an air gap (recommended) it requires periodic cleaning. The air gap is not part of the washer; therefore, it is not covered by the washer warranty. The air gap protects the washer against water backing up in the event of a clogged drain. Check the air gap for build-up any time your washer is not draining well.

Most types of air gaps are easy to clean. Simply follow the manufacturer's directions for maintaining the air gap.

### Maintaining the Water Fill Valve

The water fill valves on the washer includes a filter screen to remove dirt/particulate in the supply water lines. The filter screens may require periodic cleaning to remove trapped particles. A low water condition or Fill Fail Alarm may occur if the blockage is not removed. See Fig. 8-1, and follow these steps to clean the inlet valve filter screen.

1. Turn off the water and disconnect electrical power to the washer.
2. Gain access to the rear of the washer. If the washer is a Freestanding model, remove the rear panel.
3. Disconnect the water supply line that is connected to the valve to be cleaned.
4. Remove the valve filter screen and clean it thoroughly under running water.

5. Replace the screen and reassemble the valve connection. Verify the gasket on the hose fitting is in position when connecting to the fill valve body.

**Figure 8-1**

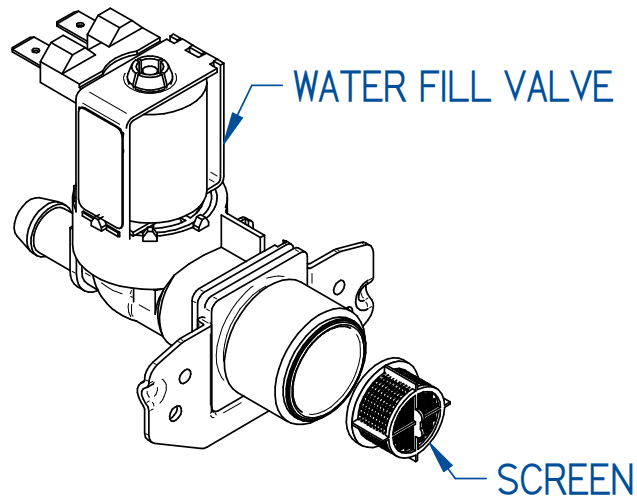

### Cleaning the Sump Filter Screen

If debris accumulates on the filter screen that is located in the washer sump the performance of the washer may be affected. The sump filter screen must be removed and cleaned periodically. The washer is programmed with a default reminder to clean the sump every 173 hours of operation. This reminder can be turned off by setting the reminder hours to zero (see [Section 5: Maintenance](#) for additional details), or the interval changed if desired. Go to the Settings Screen, then select *Maintenance* to reset or change the reminders timer. See Fig. 8-2, and follow these instructions to clean the filter screen.

1. Open the washer door and remove the lower rack.
2. If the optional Heater Cover is installed, remove it.
3. Remove the thumb screw that retains the filter screen.
4. Carefully lift the screen and pull outward, using care not to drop debris into the sump.
5. Clean the screen using a mild detergent and clean water.

6. When replacing the screen make sure the two tabs on the bottom of each side of the distribution tube slide under the metal plate in the back of the sump and the screen is seated in the sump emboss of the tank floor.
7. Re-secure the screen to the sump with the thumb screw.

**Figure 8-2**

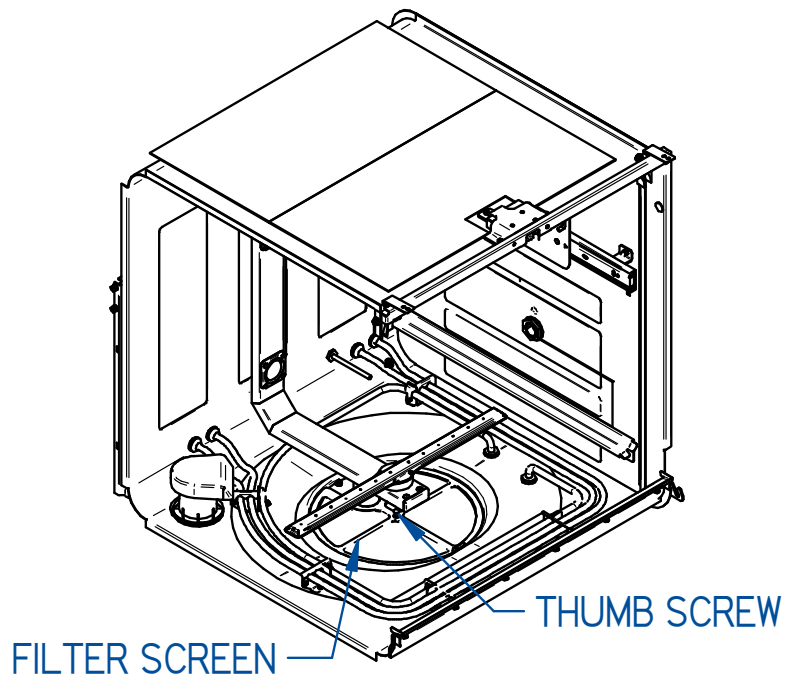

## Replacing the HEPA Filter (PN4597300)

After an extended period of time, dirt and debris may block the air flow through the HEPA filter. The HEPA filter is available from Labconco (Catalog Number 4597300). The filter may be replaced by following the instructions below:

1. Open the left door by pressing it in the right side.
2. Press down on the lock tab on the top of the HEPA filter and pull the top of the filter outwards.
3. Lift the filter out of the bottom retainer.

**Figure 8-3**

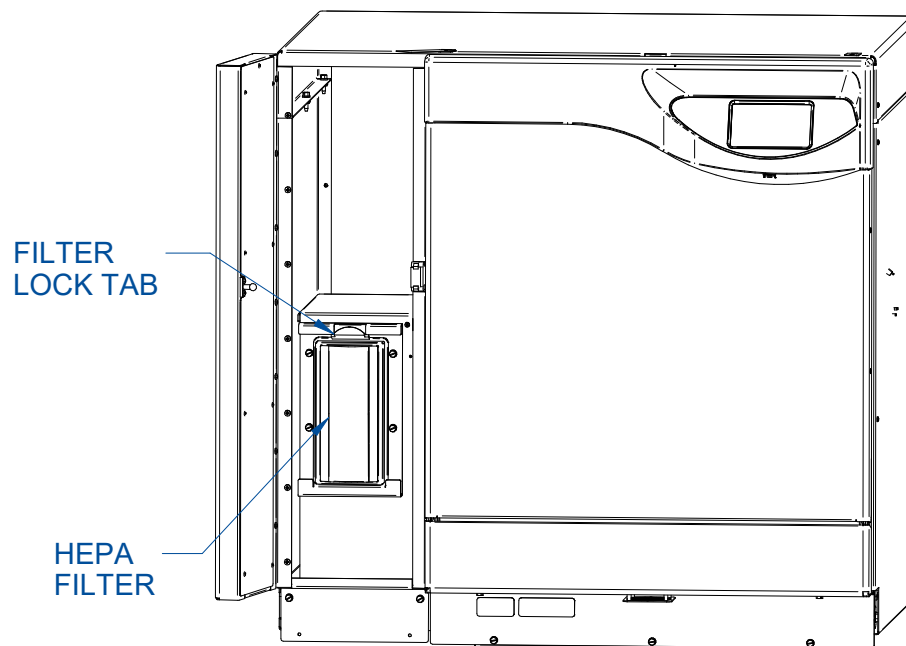

## Maintaining the Conductivity Sensor

The operation of the Conductivity Sensor may degrade if it becomes contaminated with soil from glassware that has not been rinsed prior to being placed into the washer or if it becomes coated with minerals from the water supplied to the washer. If cleaning the sensor fails to correct the problem, the sensor should be replaced. If the interior of the washer is discolored and appears to be coated with a film, there is a good possibility that the conductivity sensor is also coated. Follow the directions for removing film or spots from the washer interior described previously in this section.

### Cleaning the Conductivity Sensor

If the soil from un-rinsed glassware has coated the sensor, the sensor may be cleaned using a solvent compatible with the soil. Remove the sump filter screw as described previously in this section. Using a swab moistened with solvent, remove the soil from metal parts inside the tubular portion. See Fig. 8-4.

**Figure 8-4**

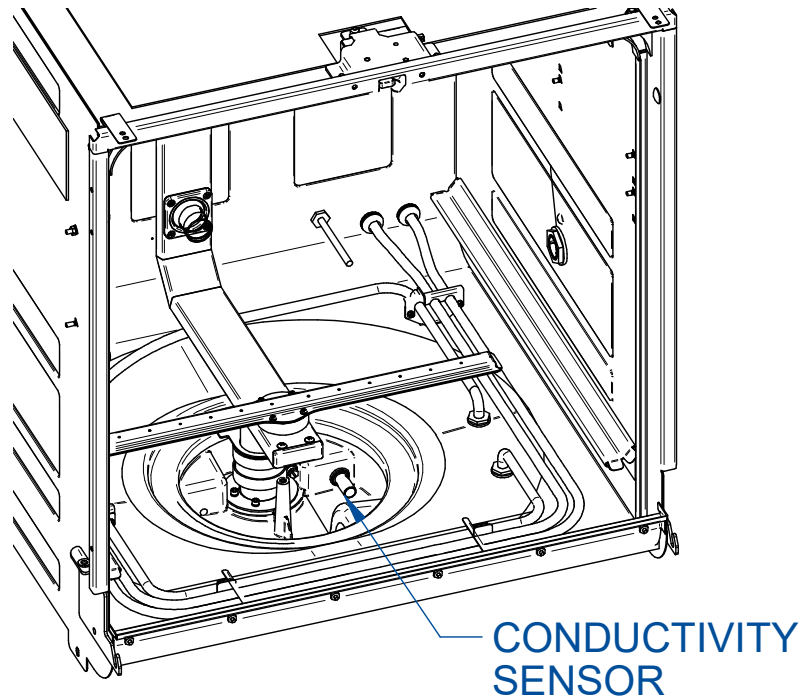

## Recommended Maintenance Schedule

Perform the maintenance operations described previously in this section in accordance with the frequency recommendations in Table 8-1. Failure to perform these maintenance operations may impair the performance of the Glassware Washer.

**Table 8-1**

Activity	Maintenance Frequency		
	Weekly	Monthly	Annually
Wipe down exterior surfaces of the stainless steel door and wrapper	•		
Run the Clean Washer Program		•	
Check and clean the Sump Filter Screen		•	
Check and clean the inlet valve filter screen(s)			•
Check and clean the drain Air Gap			•
Replace HEPA Filter			•
Clean Conductivity Sensor			•

## 9: Accessories & Consumables

---

This section details the available field-installable accessories and approved modifications for your glassware washer.

### Rack Inserts for Labware

All inserts can be used in all Labconco Glassware Washer models. Catalog numbers are listed in Table 9-1 below.

**Table 9-1**

<b>Insert Description</b>	<b>Catalog Number</b>
Tray Insert	4573000
Utensil Basket	4573100
Petri Dish Insert	4589701
Mesh Basket	4573400
Bulk Tube Insert	4573500
Culture Tube Insert, 10 - 12 mm Tubes *	4573600
Culture Tube Insert, 15 – 18 mm Tubes	4573700
Culture Tube Insert, 20 – 24 mm Tubes	4573800
Retainer Top	4573900
10-Pin Insert	4401501
32-Pin Insert	4401801
48-Pin Insert	4574200
Retainer Top, 10-Pin and 32-Pin Inserts	4401901
Utensil Holder	4575200

\* Includes Retainer Top 4573900

Catalog numbers of inserts that require a spindle rack are listed in Table 9-2.



A lower spindle rack is included standard on FlaskScrubber Vantage Series models.

**Table 9-2**

Insert Description	Catalog Number
Graduate Insert	4574600
Test Tube Insert, 10 – 13 mm tubes *	4574700
Test Tube Insert, 14 – 20 mm tubes *	4574800
Test Tube Insert, 20 – 25 mm tubes *	4574900
Test Tube Spindle Conversion Kit	4575300
Vial Insert, 12 x 32 mm vials	4574400
Vial Insert, 15 x 45 mm vials	4574500
Pipette Insert (6)	4575500
Pipette Insert (24)	4575400

\* Requires 4575300

## Racks

Additional racks expand the capability of glassware washers. Catalog numbers are listed in Table 9-3.

**Table 9-3**

Rack Description	Catalog Number	Additional Information
Upper Spindle Rack	4668500	36 Large Spindles, includes Slides
Upper Spindle Rack	4668600	36 Large Spindles, excludes Slides
Upper Small Spindle Rack	4668501	60 Small Spindles, includes Slides
Upper Small Spindle Rack	4668601	60 Small Spindle, excludes Slides
Lower Spindle Rack *	4668900	36 Large Spindles
Lower Small Spindle Rack	4668901	60 Small Spindles
Upper Standard Rack **	4668700	Includes Slides
Upper Standard Rack	4668800	Excludes Slides
Lower Standard Rack **	4669000	
Upper Rack Retrofit Kit	4670600	For washers built prior to 11/20

\* Indicates rack is supplied standard with Vantage models.

\*\* Indicates rack is supplied standard with SteamScrubber models.

## Rack Accessories

Glassware holders and small spindles allow spindle racks to be modified to suit specific requirements. Catalog numbers are listed in Table 9-4 below.

**Table 9-4**

Insert Description	Catalog Number
Large Stainless Steel Glassware Holder	4424800P
Small Stainless Steel Glassware Holder	4424600P
Universal Plastic Glassware Holder	4585204
Small Spindles and Clips (10 pack)	4670800
Spray Spindle	4575700
Wash Arm with 5 Small Spindles	4575800
Silicone Spindle Tip (40 pack)	4669540

## Heater Cover Kit

A heater cover provides a protective barrier between the washer chamber and the heater coils to prevent objects that may become dislodged during washing from contacting the heater coils. Catalog numbers are listed in Table 9-5 below.

**Table 9-5**

Heater Cover Fits	Catalog Number
Vantage	4679301

## Cool Drain Water Kit

The Cool Drain Water Kit mixes cool water with hot washer drain water to lower the temperature of the water to meet certain drain temperature regulations. Catalog numbers are listed in Table 9-7 below.

**Table 9-6**

Cool Drain Water Kit Fits	Catalog Number
230 V Models	4678401

## Base Stand

Base Stands are used to elevate glassware washers to make loading and unloading more ergonomic for the user. Supplies may also be stored in the base stand's integral cabinet. Catalog numbers are listed in Table 9-9 below.

**Table 9-7**

Base Stand Fits	Catalog Number
Vantage Models	4653300

## Printer Cable Kit

This kit provides the capability to connect a printer to the glassware washer. The catalog number is listed in Table 9-11 below.

**Table 9-11**

Printer Cable Kit Fits	Catalog Number
Vantage Models	4681301
Thermal Printer Paper	483700

## RO Storage Tank

RO Storage Tanks provide additional storage of pressurized reverse osmosis water for use with all glassware washers to accommodate rinsing glassware with pure water. Catalog numbers are listed in Table 9-12 below.

**Table 9-12**

RO Storage Tank Size	Catalog Number
20 Gallon	9201000
14 Gallon	9201001

## ScrubberMate Cart

This cart provides convenient storage and transport for racks and inserts as well as miscellaneous glassware. The catalog number is listed in Table 9-13 below.

**Table 9-13**

Description	Catalog Number
ScrubberMate Cart	8027000

## Consumables

Consumables recommended for use in glassware Washers are listed in Table 9-14.

**Table 9-14**

Description	Catalog Number
LabSolutions Powder Detergent 10 lb. (4.5 kg)	4422000
LabSolutions Powder Detergent 27.5 lb. (12.5 kg)	4422100
LabSolutions Liquid Detergent 1 gal (3.8 L)	4522000
LabSolutions Neutralizing Acid Rinse 34 oz. (1 L)	4522200
HEPA Filter	4597300
Thermal Printer Paper	4683700

## RO Connection Kit

The Labconco Interconnect Kit is supplied with hardware and tubing to install a WaterPro RO Station or a storage tank to a glassware washer.

**Table 9-15**

Description	Catalog Number
RO Connection Kit	9100200

## 10: Troubleshooting

This section details common troubleshooting for your Glassware washer.

Refer to the following table if your Glassware Washer fails to operate properly. If the suggested corrective actions do not solve your problem, contact Labconco Product Service for additional assistance.

Problem	Alarm Code	Possible Cause	Diagnostic Test	Possible Corrective Action
<b>Low Auto Rinse Aid</b>	<b>A1</b>	Rinse Aid level low.	Check Rinse Aid level.	Refill or replace Rinse Aid bottle.
		Float movement restricted.	Check Sensor Screen for reading and float function.	Clean float on dip tube.
		Bad wiring connection.	Check wire connections.	Correct wiring.
		Auto Rinse Aid not used.		Turn Auto Rinse Aid dispense off in Accessories. Dismiss alarm.
<b>Conductivity Sensor</b>	<b>CS</b>	Conductivity sensor disconnected.	Check wire connections.	Correct wiring.
		Bad conductivity sensor.	Check Sensor Screen for a conductivity value.	If no reading and wiring connected replace conductivity sensor.
<b>Low Auto Detergent</b>	<b>D1</b>	Auto Detergent level low.	Check Auto Detergent level.	Refill or replace Detergent bottle.
		Float movement restricted.	Check Sensor Screen for reading and float function.	Clean float on dip tube.
		Bad wiring connection.	Check wire connections.	Correct wiring.
		Auto Detergent not used.		Turn Auto Detergent dispense off in Accessories. Dismiss alarm,
<b>Drain Fail</b>	<b>DF</b>	Clogged Sump screen.	Visual inspection.	Clean sump screen.
		Drain line partially restricted, kinked or improperly installed.	Drain All The Way: check for water output from drain hose.	Fail: Clear drain line, remove kink or correct installation.

		Drain Valve not operating.	Drain Valve Test: Listen for click when actuated.	Fail: If valve is getting power replace valve. If no power, check wiring or IOB output
		Drain pump not operating.	Drain Pump Test: Listen for pump	Fail: If pump is getting power replace pump. If no power, check wiring or IOB output.
		Pump lost its prime.	Drain All The Way Test: drain time and flow rate	Fail: Check drain hose for sumping between pump and high loop. Drain water from drain hose and retest Drain All The Way
		Defective Relay	Check for 12VDC to drain pump and drain valve relay coils when actuated in diagnostics	If 12VDC to coil OK replace valve
		Defective fill level sensor.	With water in sump check Sensor Screen for readings Fill level sensor should be 0 when empty and >75 full.	Fail: Replace and calibrate Fill Level Sensor.
		Defective controller.	Check output from PCB to drain valve and pump.	Replace IOB. Contact Labconco Product Service.
<b>Door Latch Fail</b>	<b>DL</b>	Door switch opens during cycle.		Shut Door.
<b>DL is a Fatal Alarm and requires a power reset to clear once fault is resolved.</b>		Door switch not actuated.	Door Latch Test: Check door latch function.	Pass: Adjust door striker or door hinge pins for positive actuation of door switch/latch.
		Door latch switch/latch not working.	Check wire connections.	Fail: If latch is getting power replace latch. If no power, check wiring or IOB output
<b>Door Open</b>	<b>DO</b>	Door switch is open when trying to start cycle.		Shut Door.

<b>Fill Fail</b>	<b>FF</b>	Improper water supply tap.	Fill All The Way tests Tap fill time and flow rate.	Fail: Make sure water is turned on with no restrictions.
				Tap water pressure must be at least 20 psi (138 kPa) and flow must be at least 0.7 gallons (2.6 liters)/minute.
		Improper water supply pure.	Pure Fill All The Way tests Pure fill time and flow rate.	Fail: Make sure pure water is turned on with no restrictions.
				DI water supply must have volume of 3.4 gallons (4.7 liters) per fill and flow of at least 0.7 gallons (2.6 liter)/minute.
		Defective fill valves.	Fill Valve Test (Hot Top or Pure): Test valve operation.	Pass: Clean screens inside the inlet fittings of the water valves.
			Fill Valve Test (Hot Top or Pure): Test valve operation.	Fail: If valve is getting power replace valve. If no power, check wiring or IOB output
		Defective DI water pump.	Pure Pump Test: Test pump operation.	Fail: If pump is getting power replace. If no power, check wiring or IOB output
		Are leak in hose connections to water level sensor.	Check Sensor Screen: >75mm when full no loss of pressure after 5 minutes. Fill washer. check water level in transparent tubing to pressure sensor, water should not move up into the tube over time.	Fail: Repair air leak.
		Defective fill level sensor.	Check Sensor Screen: <75mm when full.	Pass: Recalibrate sensor. Contact Labconco Product Service.

		False positive on Overfill Sensor	Mfg Sept 2025 or before: Sensor's blue light on with no water in washer	Fail: Upgrade to current Overfill Sensor
		Defective controller.	Check output from IOB to both valves and DI pump.	Fail: Replace IOB.
<b>Firmware</b>	<b>FI</b>	Firmware not responding.		Power Reset, reinstall firmware or Factory Reset
<b>High Water</b>	<b>HW</b>	Water level set point to high.	FILL ALL THE WAY Water level over distribution tube.	Pass: Recalibrate sensor. Contact Labconco Product Service.
		Inlet Valve failure.	Check water inlet in side of tank for water leaking when unit off.	Replace Inlet Valve
		Defective fill sensor	Check Sensor Screen: >125mm when full.	Pass: Recalibrate or replace sensor. Contact Labconco Product Service.
<b>Low Temp</b>	<b>LT</b>	Heater failure.	Heater/s Test:	Fail: If heaters are getting power and wires have conductivity, replace heater/s
			Check resistance of heater for open circuit	If open replace heater.
		Defective controller.	Check output from IOB to heater.	Fail; Replace IOB. Contact Labconco Product Service.
		Defective temperature probe.	Check electrical connections.	Repair connections
		Defective high temperature cut out T-Stat.	Check resistance of safety cut out T-Stat.	If open circuit at room temperature, replace T-Stat.
<b>No Water</b>	<b>NW</b>	Leak during wash or rinse segment.	Check for leaks both under and around washer.	Fix Leaks.
		Drain Valve failure during wash or rinse segment.	Check for draining during wash segment.	Replace drain valve.
<b>Over Flow</b>	<b>OV</b>	Water in base.	Check for leaks under wash tank.	Repair leaks under wash tank or inlet valves

<b>Program Canceled</b>	<b>PC</b>	Program canceled by operator or Fatal Alarm.	No action required.	No action required if manually canceled. Determine cause if by another Fatal Alarm.
<b>Power Fail</b>	<b>PF</b>	Power Outage.	No action required.	Program will resume at the beginning of interrupted segment.
<b>Program Pause.</b>	<b>PP</b>	Door opened or program paused by operator.	No action required.	Restarting program will resume where paused.
<b>Low Rinse Aid Cup</b>	<b>RA</b>	Rinse Aid in door low		Refill Rinse Aid in door or dismiss alarm.
		Rinse Aid Cup not used.		Turn Rinse Aid Cup dispense off in Accessories.
<b>Step Skipped</b>	<b>SS</b>	Segment Skipped by operator.	No action required.	Program will drain and begin next programmed segment.
<b>Temp Sensor</b>	<b>TS</b>	Temperature Sensor failure.	Check Sensor Screen for temp reading.	If no reading and wiring connected replace sensor.
<b>Fill Valve</b>	<b>FV</b>	Fill Valve failed open	Check Fill Valve for leak into tank	Replace fill Valve
<b>Open buttons or display on control panel inoperable or controls malfunction</b>		Microprocessor memory error.		Perform "Factory Reset."
		Keypad or display defective.		Replace key pad or display or IOB.
<b>Detergent cup in door fails to open</b>		Glassware interfering with cup door.		Move glassware.
		Malfunction of cup.	Detergent Cup Test: with door closed	Fail: If cup is getting power and wiring has continuity replace Detergent cup.
		D-cup latch fouled.	Manually test door operation.	Clean D-cup latch

<b>Poor drying</b>		Dry temperature too low.		Program warmer dry temperature.
		Flask, beaker, or labware with concave bottoms not loaded correctly.		Tilt these articles when loading so that water drains off.
		Recondensation.		If labware is left in the washer, recondensation may occur. Open latch or program Auto Unlock after completion of cycle to allow moisture-laden air to escape.
		Dry time too short.		Program longer time.
		Heater(s) disconnected or malfunctioned	Heater/s Test:	Reconnect or replace heater.
		Blower disconnected or malfunctioned.	Dry Bower Test.	Reconnect or replace blower.
<b>Poor washing results</b>		Water is not hot enough.	Check Wash water temperature setting	. Should be at least 120°F (49°C). Recommended temperature is 150°F (66°C).
		Improper loading	Check washer loading	instructions in <i>Chapter 7</i> in this manual.
		Detergent too old or amount wrong.		Replace detergent or change quantity used.
		Detergent caked in D- Cup.		Clean D-Cup. Replace with fresh detergent. Check water inlet temperature. Should be at least 120°F (49°C).
		Insufficient wash time.		Increase wash cycle time.
		Wash arms not spinning.		Remove and clean wash arms.
		Glassware interfering with cup door.		Move glassware.
<b>Tank and inner door have surface rust</b>		Glassware is contaminated with acids.		Pre-rinse glassware. Clean with stainless steel cleaner and soft cloth.

<b>Washer does not run</b>		No power to washer.		Check fuse or circuit breaker.
		Improper wiring	Check wiring to unit	Correct wiring
		12 V power supply	Check power to and out of 12V power supply.	If input OK and output 12VDC replace power supply
<b>Washer door opens and closes badly</b>		Cabinet opening is not square.		Correct opening with leveling feet.
		Door hitting counter-top mounting screws.		Adjust mounting screws.
		Door not sealing or door too tight.		Adjust hinge pins or door striker.
<b>Washer leaks</b>		Improper detergent.	Check detergent for foaming.	Use non-foaming detergent. Use only proper amount of detergent.
		Tank sump gasket.	Check sump fasteners.	Tighten nuts or replace o-ring. Do not over tighten nut.
		Washer is not level.	Check with level	Adjust leveling feet.
		Loose connection at hose clamps.		Tighten hose clamp.
		Loose connection at fill valve.	Check water supply/ fill valve connection.	Tighten or replace seal.
		Obstruction in drain line.		Remove obstruction.
		Washer overfilling.	Check operation of fill sensor.	Recalibrate or replace water level sensor.
<b>Washer leaks around door seal</b>		Improper installation.		Check the cabinet opening to see if it is aligned properly with the door, adjust feet.
		Unit not level.		Adjust feet to level unit.
		Door latch	Check door latch for proper sealing.	Adjust hinge pins or door striker.
<b>Ethernet connectivity</b>		No Network.	Confirm network	Connect to valid network.
		DHCP Enabled: setting switched off	Check DHCP Enabled setting	Turn DHCP Enabled ON.

## Appendix A: Parts List

---

Table A-1 lists catalog numbers for service and replacement accessory components.

**Table A-1**

Description	Catalog
LED Light Assembly	4671400
Inlet Valve 12V	4670500
Drain Valve 230V	4586901P
Drain Valve 115/230V*	4585600
Drain Pump 230V	4663401P
Pure Pump 12V	4527900
Wash Pump 230V	4584201
Pressure Sensor Board	4674200
Overfill Sensor (Mfg. after 9/2025)***	4689200
Overfill Sensor Upgrade Kit (Mfg. 9/2025 or before)***	4689010
IO Board	4687600
Display Board	4688400
Detergent Dispenser Kit	4671701
Blower 12V	7909600
Power Supply 12V	4678500

\* Units manufactured after 07/22

\*\*Units manufactured before 08/23

\*\*\* Mfg. Dates Approx.

## Appendix B: Dimensions

---

The following figures provide product dimensions. All dimensions shown in inches (centimeters).

### FlaskScrubber Vantage Series Exterior Dimensions

**Figure B-1**

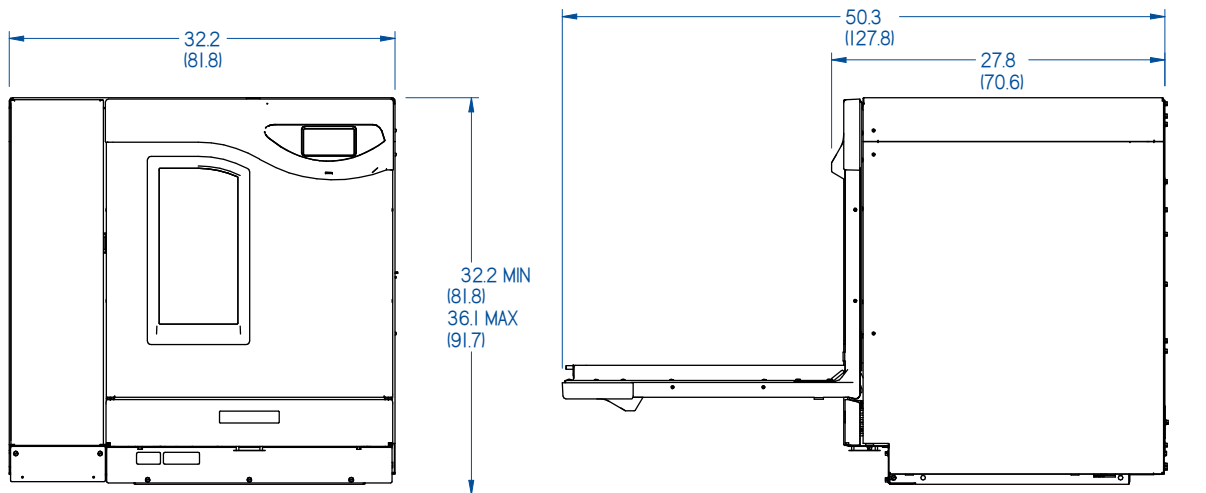

### FlaskScrubber Vantage Series Interior Dimensions

**Figure B-2**

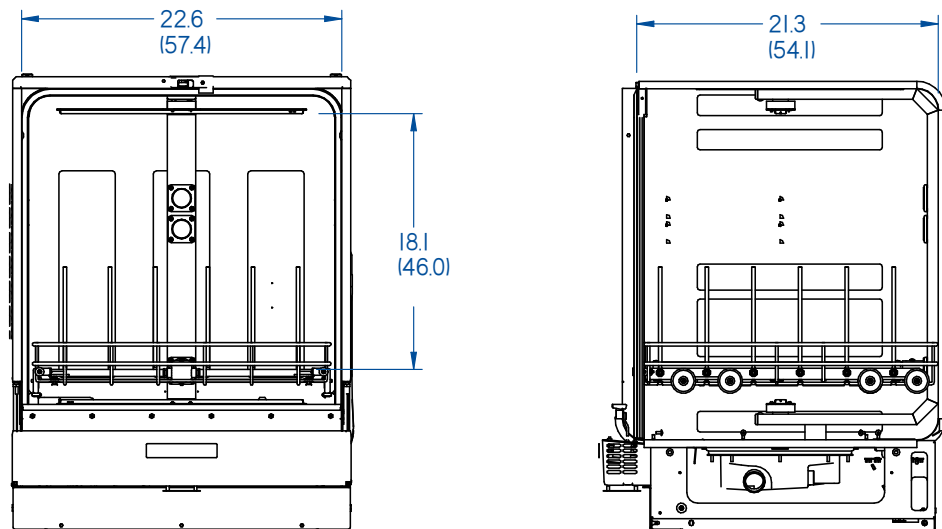

## Appendix C: Specifications

This Appendix contains specifications for the Glassware Washer, including estimated program times and water consumption.

### Programs

**Table C-1**

FACTORY PROGRAMS: FLASKSCRUBBER VANTAGE SERIES												
Segment	Rinse Only	Plastic	Glass	Glass Plus	Life Scientific	Analytical	Intense*	Extreme*	Dry Only	Eco Wash	Clean Washer	CleanPoint
<b>Pre-Wash Time</b>												
Wash Time		5	5	5	5	5	5	10		5	1	5
Temperature (°C)		38	38	38	38	38	38	38		38	80	38
Tap Fill		X	X	X	X	X	X	X		X	X	X
Pure Fill												
Det Disp Cup (Auto mL)							A20	A20				A20
<b>Wash 1</b>												
Steam Time				10	10			10				
Wash Time		10	10	15	20	20	30	40		10		5
Temperature (°C)		50	60	70	80	70	93	93		60		93
Tap Fill		X	X	X	X	X	X	X		X		X
Pure Fill												
Det Disp Cup (Auto mL)		Cup	Cup	Cup	Cup	Cup	A20	A20		Cup		
<b>Wash 2*</b>												
Steam Time								10				
Temperature (°C)							93	93				
Wash Time							30	40				
Tap Fill							X	X				
Pure Fill												
Auto Det Disp (mL)							A20	A20				
<b>Rinse 1/8 Tap</b>												
Rinse Time	5	5	5	5	5	5	5	5		5	1	4
Temperature (°C)	38	38	38	38	38	38	38	38		38	80	38
Tap Fill	X	X	X	X	X	X	X	X		X	X	X
Pure Fill												
Rinse Aid Cup ml (Auto mL)		Cup 4	Cup 4	Cup 4	Cup 4	Cup 4	A 4	A 4		Cup 4		A 4
<b>Rinse 2/8</b>												
Rinse Time		5	5	5	5	5	5	5				2
Temperature (°C)		50	60	38	38	38	38	38				38
Tap Fill		X	X	X	X	X	X	X		X		
Pure Fill												X

<b>Segment</b>	<b>Rinse Only</b>	<b>Plastic</b>	<b>Glass</b>	<b>Glass Plus</b>	<b>Life Scientific</b>	<b>Analytical</b>	<b>Intense*</b>	<b>Extreme*</b>	<b>Dry Only</b>	<b>Eco Wash</b>	<b>Clean Washer</b>	<b>CleanPoint</b>
<i>Rinse Aid Cup ml (Auto mL)</i>		Cup 4	Cup 4	Cup 4	Cup 4	Cup 4	A 4	A 4		Cup 4		
<b>Rinse 3/8</b>												
Rinse Time				5	5	5	5	5				2
Temperature (°C)				70	38	38	38	38				38
Tap Fill				X	X	X	X	X				
Pure Fill												X
<i>Rinse Aid Cup ml (Auto mL)</i>												
<b>Rinse 4/8</b>												
Rinse Time					5	5	10	5				2
Temperature (°C)					70	70	38	38				38
Tap Fill					X	X	X	X				
Pure Fill												X
<i>Rinse Aid Cup ml (Auto mL)</i>												
<b>Rinse 5/8</b>												
Rinse Time							5	5				2
Temperature (°C)							93	93				38
Tap Fill							X	X				
Pure Fill												X
<i>Rinse Aid Cup ml (Auto mL)</i>												
<b>Rinse 6/8</b>												
Rinse Time												2
Temperature (°C)												38
Tap Fill												
Pure Fill												X
<i>Rinse Aid Cup ml (Auto mL)</i>												
<b>Rinse 7/8</b>												
Rinse Time												2
Temperature (°C)												38
Tap Fill												
Pure Fill												X
<i>Rinse Aid Cup ml (Auto mL)</i>												
<b>Rinse 8/8</b>												
Rinse Time												2
Temperature (°C)												38
Tap Fill												
Pure Fill												X
<i>Rinse Aid Cup ml (Auto mL)</i>												
<b>Dry</b>												
Dry Time		15	30	60	40	40	50	60	60	15	30	30
Temperature (°C)		60	70	80	70	80	70	80	80	80	80	80
Open Door										5		
Total Estimated Time**	10	57	81	141	131	119	230	265	60	53	58	152

\*Programs with Wash 2 are only available with Auto Dispense option.

\*\*Estimated times based on 3-phase unit. 49C water supply. Actual heat rates, fill and drain times will vary.

## Power Data

**Table C-2**

Catalog Number	Volts	Phase	Cycles	Amps*
422101010	208/230	1	50/60	11.0
422101013	208/230/400	3	50/60	21/19/9

\* Amperage values may vary depending upon supply voltage.

## Fill and Heat Specifications

- Minimum fill water temperature: 120°F (49°C) recommended
- Maximum fill water temperature: 199°F (93°C)
- Water consumption per fill: 3.4 gallons (13 L)
- Minimum tap feed water pressure: 20 psi (138 kPa)
- Maximum tap feed water pressure: 120 psi (827 kPa)
- Minimum tap feed water flow rate: 0.7 gallons (2.7 liters) per minute
- Minimum feed purified water pressure: 0 psi (0 kPa)
- Maximum feed purified water pressure: 120 psi (827 kPa)
- Minimum pure water flow rate: 0.7 gallons (2.7 liters) per minute
- Heat rejected from washer\* 2000W: < 114 BTU/minute
- Heat rejected from washer\* 6000W: < 341 BTU/minute
- Water heating rate^ 230V 2000W: 3.1°F/minute (1.7°C/minute)
- Water heating rate^ 208V 6000W : 5.8°F/minute (3.2°C/minute)

\*Wash Pump and Heater(s) On

^2000W and 6000W Models - Heat Rate from 50°C to 93°C

## Environmental Conditions

- Indoor use only
- Ambient temperature range: 41° to 95°F (5° to 35°C)
- Maximum altitude: 10,000 feet (3,048 meters).
- Maximum relative humidity: 70% for temperatures up to 78°F (31°C), decreasing linearly to 40% relative humidity at 95°F (35°C)
- Main supply voltage fluctuations not to exceed  $\pm 10\%$  of the nominal voltage
- Transient overvoltages according to Installation Categories II (Overvoltage Categories per IEC 1010). Temporary voltage spikes on the AC input line that may be as high as 1500V for 115V models and 2500V for 230V models are allowed
- Used in an environment of Pollution degrees 2 (i.e., where normally only non-conductive atmospheres are present). Occasionally, however, a temporary conductivity caused by condensation must be expected in accordance with IEC 664